



# Designa Schist

TECHNICAL MANUAL

**nzbrick**<sup>TM</sup>  
DISTRIBUTORS

[www.nzbrickdistributors.co.nz](http://www.nzbrickdistributors.co.nz)



# Contents

---

## Designa Schist Technical Manual

<b>1.0 Preliminary Comment</b>	<b>Page</b>
1.1 Limitations .....	4
1.2 Acceptable Solution .....	4
1.3 Responsibilities .....	4
1.4 Available Colours .....	4
1.5 Colour Variation .....	4
1.6 Technical Details .....	4
1.7 Placing Orders and Quantity Take-off .....	4
<b>2.0 Schist Brick Product Specification</b>	
2.1 Product Data Sheet .....	5
2.2 Individual Product Unit Dimensions .....	6
2.3 Modular Z Brick Manufacturing Specification .....	8
<b>3.0 Installation and Handling Instructions</b>	
3.1 Storage .....	9
3.2 Handling .....	9
3.3 Materials required for Installation .....	9
3.4 Preparation of Product .....	9
3.5 Laying of Product .....	9
3.6 Cleaning .....	9
3.7 Maintenance .....	9
<b>4.0 Trouble Shooting</b>	
4.1 Lichen and Moss .....	10
4.2 Rust or Iron stains .....	10
4.3 Efflorescence on stonework .....	10
4.4 Oiling Stonework .....	10
4.5 Acid Washing Information .....	10
<b>5.0 Technical Details</b>	
Fig. 1 Standard Designa Schist Veneer .....	11
Fig. 2 Flat Soffit .....	12
Fig. 3 Flat Soffit with Brick Mould .....	12
Fig. 4 Flat Soffit with Frieze Board .....	12
Fig. 5 Door Sill .....	12
Fig. 6 Window Head - Aluminium –Option 1 .....	13
Fig. 7 Window Head - Aluminium – Option 2 .....	13
Fig. 8 Window Sill - Aluminium .....	13
Fig. 9 Window Jamb - Aluminium .....	13
Fig. 10 Deep Reveal - Jamb - Using Packer .....	14
Fig. 11 Deep Reveal - Jamb - Double stud framing .....	14
Fig. 12 Control Joints .....	15
Fig. 13 Column Options 450mm & 600mm .....	16
Fig. 13A Columns - perspective .....	17
Fig. 14 Corner Construction .....	18
<b>6.0 Producer Statement .....</b>	<b>19</b>
<b>Designa Basalt Technical Manual.....</b>	<b>20</b>

# 1.0 Preliminary Comment

---

The purpose of this document is to provide a guideline for the building industry, including architects, builders, bricklayers and building officials on the correct use and installation of the Designa Schist product and system.

## 1.1 Limitations

The Designa Schist cladding product is limited in its use by the restraints that apply in NZS 3604 Timber Frame Buildings, NZS 4229 Concrete Masonry Buildings not requiring Specific Design and NZS 4210 Masonry Materials and Workmanship in regards to the a installation of masonry veneer.

## 1.2 Acceptable Solution

The Designa Schist product meets the requirements of the NZBC Clause B2, based on the in service history of other masonry units and veneers constructed using a drained and ventilated cavity.

The 'Z' brick units themselves have been manufactured to AS/NZS 4455 and can be used for providing adequate means of weather tightness as a cladding to both residential and commercial buildings in New Zealand. The product has been tested, and verified by OPUS International Consultants as having an average compressive strength of 19MPa. (June 2007).

## 1.3 Responsibilities

Like any product or cladding system, it is essential to have a clear understanding of the product and its installation; this applies to all involved in the process from the designer, the builder, to the bricklayer.

This Technical Manual is part of the manufacturer's instructions and as such, should be made familiar to all involved.

## 1.4 Available Colours

At the time of publication, Designa Schist is available in 3 natural stone finishes; Autumn Horizon, Alpine Sierra, Black Mountain – as featured in this brochure.

## 1.5 Colour Variation

Schist is a natural stone product that will vary in colour and texture. It is important to remember that samples, brochures and other marketing avenues, provide an indicative example of the selected product and its colour. Designa Schist makes every endeavour to maintain a constant standard, however, if you are not satisfied with the colour of the product upon delivery, you must advise NZ Brick Distributors prior to the laying of the product. Once the product has been laid, it is deemed to have been accepted.

## 1.6 Technical Details

The technical details and information in this document correspond to the best of our knowledge, with all legislative requirements and good trade practice. They are provided as a guide only and all detailing should be site specific and completed by a competent architectural designer.

## 1.7 Placing Orders and Quantity Take-off

Designa Schist is priced on a square metre basis. When placing an order plans should be submitted to your nearest NZ Brick Distributors agent for a take-off of quantities of individual units required to complete the project.

# 2.0

## Schist Brick Product Specification

### 2.1 Product Data Sheet

#### Designa Schist Product

	Item	Unit Weight	Dimension	Units Per Crate
1	Full Size Z Bricks	14 Kgs	550 x 200 x 80	48
2	Half Size Z bricks	7 Kgs	300 x 200 x 80	96
3	Full Size End Bricks	14 Kgs	550 x 200 x 80	48
4	Half Size End Bricks	7 Kgs	300 x 200 x 80	96
5	Full Size Corner Bricks	15 Kgs	550 x 200 x 80	48
6	Half Corner Bricks	8 Kgs	300 x 200 x 80	96
7	Sill Caps - 40mm	10 Kgs	500 x 140 x 40	72
8	Z Column Bricks - 450mm	13 Kgs	450 x 200 x 80	64
9	Z Column Bricks - 600mm	15 Kgs	600 x 200 x 80	48
10	Column Cap for 450mm Columns	35 Kgs	500 x 500 x 40	24
11	Column Cap for 600mm Columns	45 Kgs	650 x 650 x 40	19

- Product thickness: 80mm Nominal
- Weight per Square Metre: 140Kg/m<sup>2</sup> approx.

# 2.0 Schist Brick Product Specification

## 2.2 Individual Product Unit Dimensions

Full Size Z Brick  
- Stone on face only

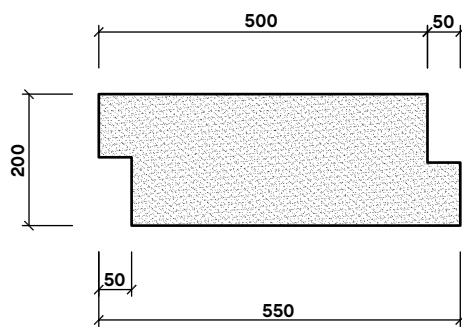

Half Size Z Brick  
- Stone on face only

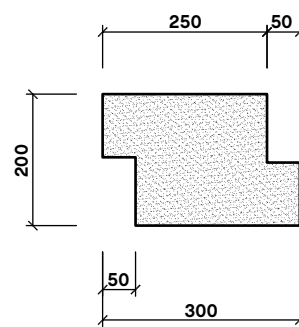

Full Size End Brick  
- Stone on face and one end

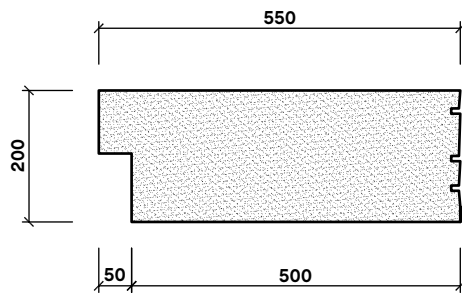

Half Size End Brick  
- Stone on face and one end

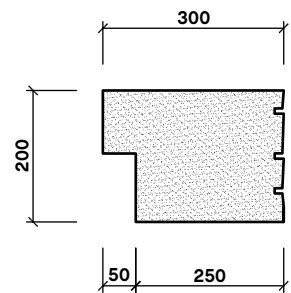

Full Size Corner Brick  
- Stone on face and one end

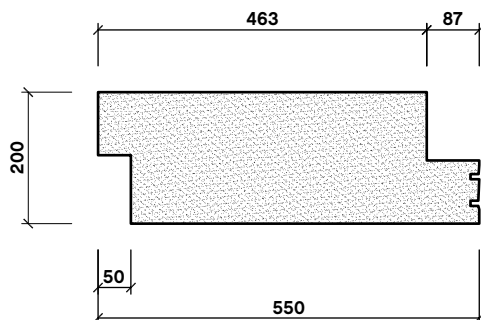

Half Size Corner Brick  
- Stone on face and one end

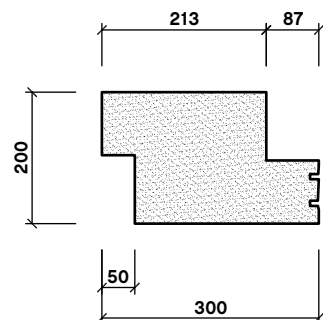

# 2.0 Schist Brick Product Specification

## 2.2 Individual Product Unit Dimensions

Sill Cap

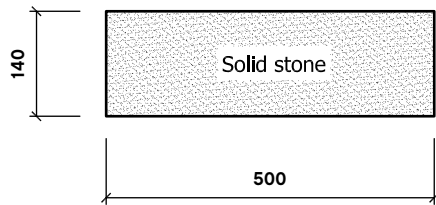

450mm Z Column Bricks  
- Stone on face and both ends

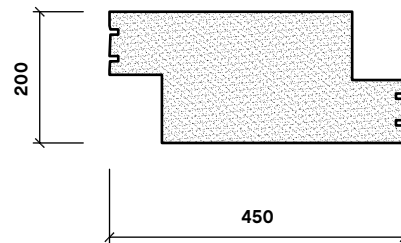

600mm Z Column Bricks  
- Stone on face and both ends

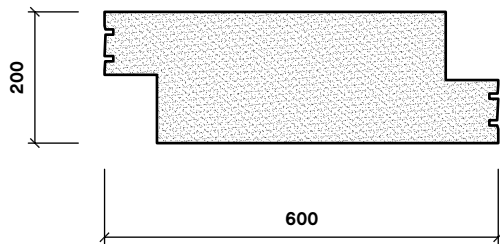

500mm Column Caps

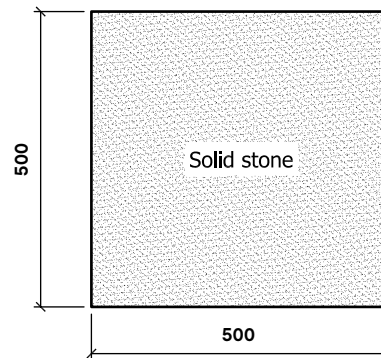

650mm Column Caps

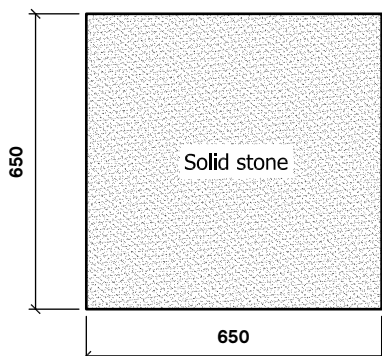

# 2.0 Schist Brick Product Specification

## 2.3 Modular Z Brick Manufacturing Specification

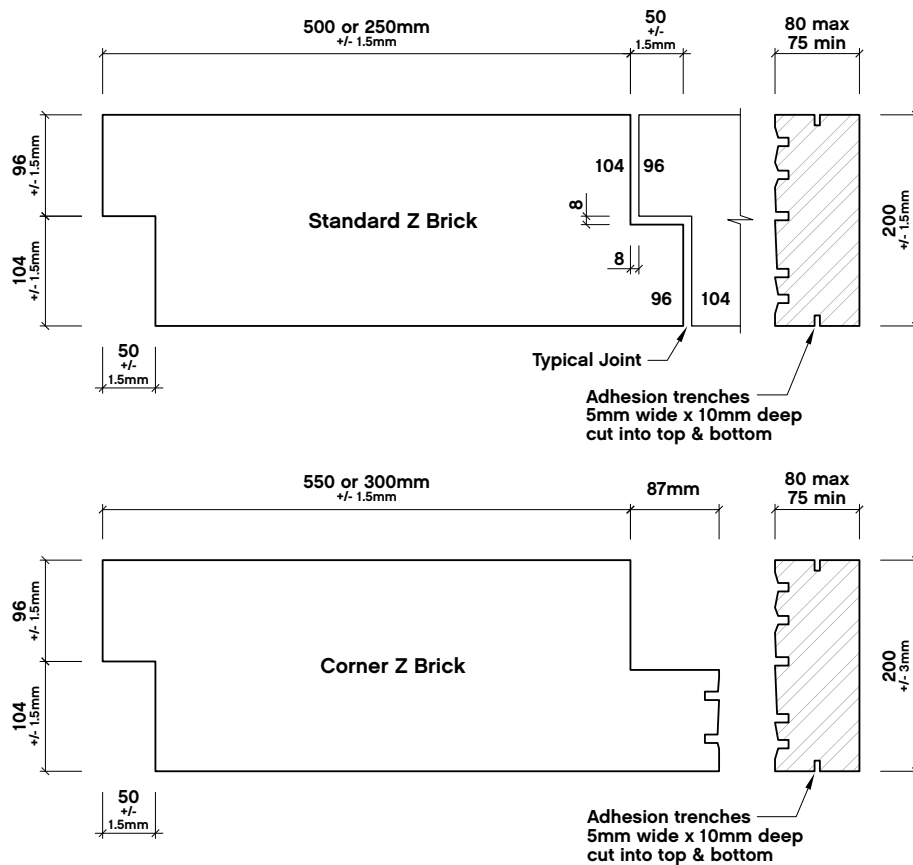

### Unit Size & Tolerance

#### Dimensional Deviation

- Each Component to the range will be +/- 5mm from the stated 'nominal size' with the exception of the front face width (80mm).
- Stone may protrude from the front face a further 5mm, however, the overall width of the combined concrete and stone unit shall not be greater than 88mm.
- The concrete component shall not be less than 50mm thick around the perimeter of each unit, with the combined front face thickness not being less than 80mm.
- Adhesion Trenches to the top and bottom of each unit shall not be less than 5mm wide and 10mm deep.

#### Mortared Look

- All Z bricks with mortared look will have a min. 6mm to 10mm mortared gaps between stones with 90% of the face compliant, in order to constitute a first grade product.
- Stone will be flush or proud of the top and bottom edges of the units so that when 7mm minimum of mortar is applied to joints they will not appear larger than the mortar in the face of the unit.



# 3.0

## Installation & Handling Instructions

### 3.1 Storage

- Keep crates in dry storage.
- Do not stack crates more than 2 high.
- Once crate straps are broken, minimise movement of crate.
- Avoid crates being exposed to the weather for long periods.
- Keep the top of the crates covered with plastic.

### 3.2 Handling

- Keep bricks apart to avoid damage when moving bricks.
- Always stack bricks on their edge not the face of the stone.
- Use gloves and avoid using all metal carrying devices to move bricks.
- Ensure the surface of where the bricks are being moved to is clean and dry.

### 3.3 Materials Required for Installation

- Trade mortar or similar sand and cement based product.
- Trowel, level and plumb bob.
- Concrete cutting saw.
- Mechanical mixer.
- Bucket of clean water and stiff brush for cleaning.

### 3.4 Preparation of Product

- Bricks should be dry and clean with no debris of any description on any of the brick.
- Laying wet bricks increases the chance of efflorescence and excessive shrinkage.
- If bricks are dirty, wash clean using water and leave to completely dry before using.
- Examine bricks to ensure there are no cracks or damage in any way.

### 3.5 Laying of Product

- Bricks should be laid in a tradesman like manner. (refer technical details).
- Mortar joints should be 10mm +/- 2mm.
- The size of the brick units ensure a number of square metres can be laid quickly. However, the size of the units also means they are much heavier than normal brick product. Therefore it is essential that the mortar is reasonably firm as you move up the wall to prevent mortar being squeezed out of the joints and the lower joints becoming less than 7mm in thickness.
- Bricks are unlikely to perfectly fit the length of a wall or the space between windows and corners and windows.

Using a diamond saw, cut the units in a Z pattern to fit the required space.

- During installation, use clean water and brush to promptly remove any fresh mortar that splashes onto the brickwork.
- Install 'Control Joints' as required. Refer Technical Details.
- Allow a minimum of 20 days from laying prior to applying any anti-graffiti coatings if specified.

### Brick Ties

- Brick ties are to be a minimum of Earthquake Medium (EM) galvanised screw-fixed ties. Use Stainless Steel ties in a sea-spray zone.
- Ties are to be installed every 200mm vertically and into studs at a maximum of 600mm crs horizontally.
- The brick tie must be a minimum of 40mm into the mortar bed - check the cavity width to ensure the correct length of tie is used.

### Veneer Cavity

- The minimum cavity width permitted is 40mm to a maximum of 75mm.
- It is recommended that a cavity of 50mm be specified however, it should be noted that a standard 85mm long brick tie cannot be used on a cavity that exceeds 45mm to comply with the requirement that the tie is 50% into the bed mortar.

### 3.6 Cleaning

- During installation, use clean water promptly and remove any fresh mortar splashes using a stiff bristle brush.
- On completion wash all surfaces with clean water.
- A light acid wash can be used if cement/mortar stains are too heavy for water to remove. Refer to instructions on the use of acid for cleaning.
- The finished appearance of the stone can be permanently spoiled, and impossible to rectify, by leaving mortar on the surface too long.
- Corium 93 available through Techmac Agencies is an appropriate alternative to using an acid to clean the stone finish. Ph 09 379 5717; 03 313 1045.
- Refer to 'Trouble Shooting' in this brochure for the management and removal of stains.

### 3.7 Maintenance

- One of the great advantages in building in Designa Schist is that it is virtually maintenance free.
- However, an annual check should be made to clean out the weep holes, brush the surface using a soft bristle brush and hose off with water. A diluted liquid detergent can be use if required.



# 4.0

## Trouble Shooting

---

### 4.1 Lichen and Moss

- The growth of lichens and mosses can occur when stonework is continually damp. They can be treated using an application of copper or ammonium sulphate or alternatively, a propriety product designed for this purpose. If the stone veneer is subject to continual moisture issues, consideration should be given to waterproofing the veneer with Surfapore C available from Lifetime Promotions Ltd (09 624 4045).

### 4.2 Rust or Iron Staining

- The brown rust stain produced by iron or steel near or embedded in stonework can usually be removed by applying a solution of oxalic acid in water (strength 1:10 by weight; 100g/L) to which has been added ammonium bifluoride (50g/L). If the stain is heavy, the solution should be applied hot, with a second application if necessary. In extreme cases, a poultice, which holds the cleaning material in contact with stone and draws the stain out, may have to be applied. Such a poultice may be made of sodium citrate, glycerine and water, in proportions 1:7:6, in a thick paste with filler such as talc and left on the stained area for several days before being brushed away.

### 4.3 Efflorescence (White Salting)

- Efflorescence is normally the result of excess moisture, particularly during the construction stage. It will usually disappear from the stonework due to the action of wind and rain. Brushing the wall down at times of maximum efflorescence will help, but do not allow the salts to accumulate at the base of the wall, as they may be carried back into the stonework by subsequent rain. Although there is no magic bullet for chemically removing white salting, Corium 93 has proven successful on occasions.

### 4.4 Oiling of Stonework

- The process of 'oiling' the stonework is an option to give the stone a darker shade and particularly where mortar staining and the like have not been successfully removed at the time of laying, this coating will improve the appearance of the job. It is also a good solution for masking the appearance of long term white salting on the stonework. The solution consists of one part clean engine oil and one part kerosene mixed well and either brushed or sprayed onto the stonework. It may be necessary to repeat this application from time to time.

### 4.5 Acid Washing Information

- If acid cleaning is called for, refer to the manufacturer's instructions and remember that the acid attacks the mortar first. This means the mortar in the joints as well as any mortar smeared on the surface. To begin with, remove as much mortar as possible first, we recommend that all chemicals added to the surface be washed off with copious quantities of water as soon as is practical. Use lots of water - do not over do the acid treatment. 1:10 parts of acid is powerful enough and even 1:20 may do the job. The use of Corium 93, specifically designed for the removal of mortar, is a good alternative to normal acid washing procedures.

#### Procedure:

- Wet the area concerned prior to applying the acid.
- Choose an inconspicuous area to test the strength of the acid to remove the mortar.
- On completion wash the area with copious amounts of water.

**Note:** After the bubbling has stopped, try not to let the acid scum dry on the surface, clean off immediately as it may prove impossible to shift once it has solidified.

# 5.0 Technical Details

Fig. 1 Standard Designa Schist Veneer

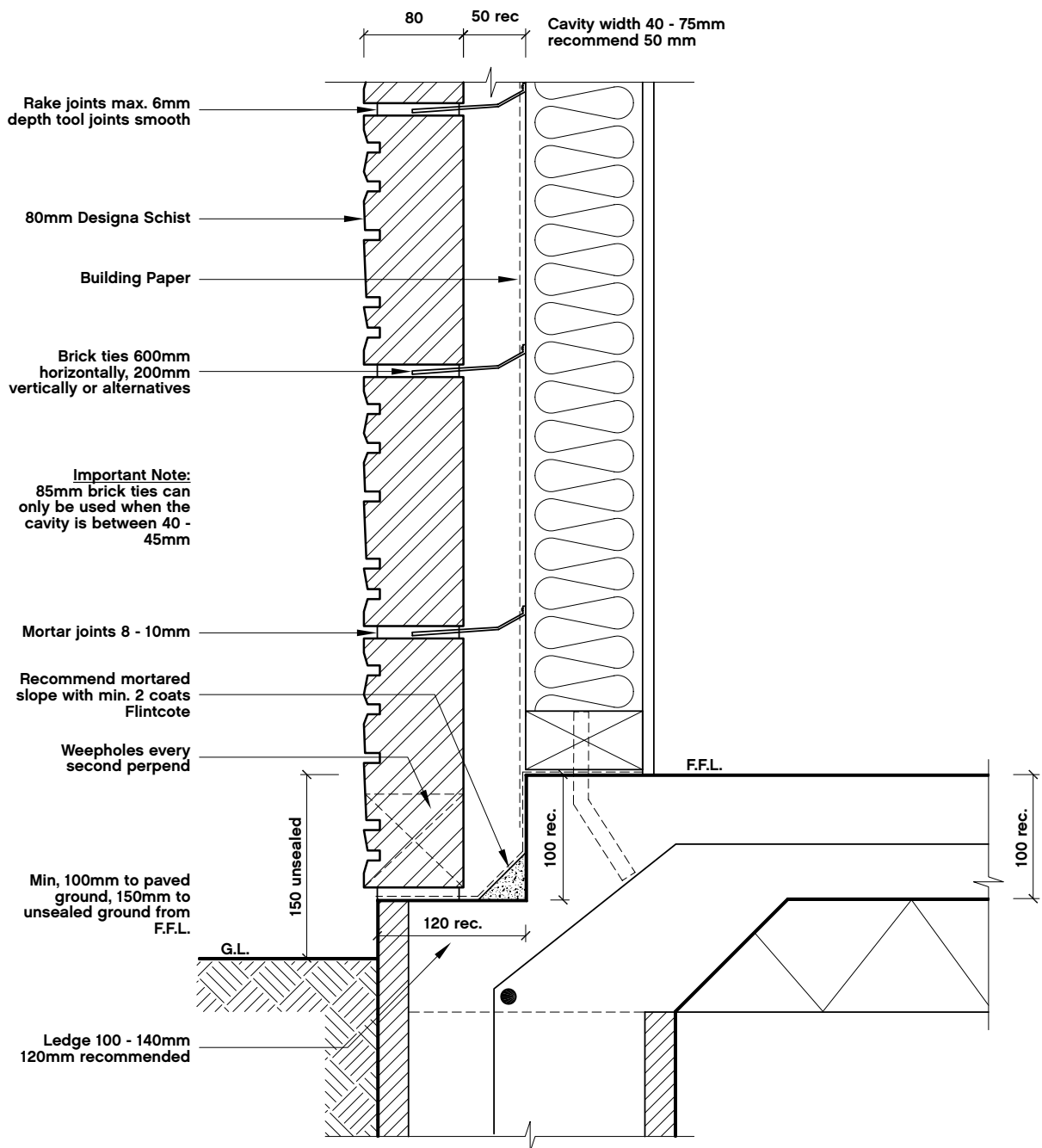

# 5.0

## Technical Details

Fig. 2 Designa Schist  
- Flat Soffit

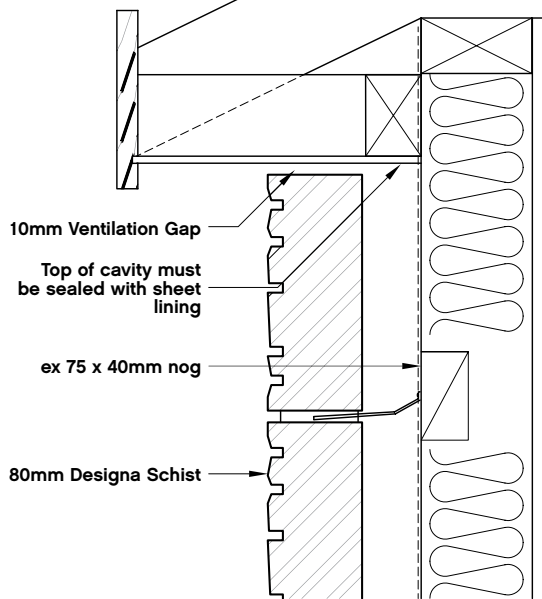

Fig. 3 Designa Schist  
- Flat Soffit

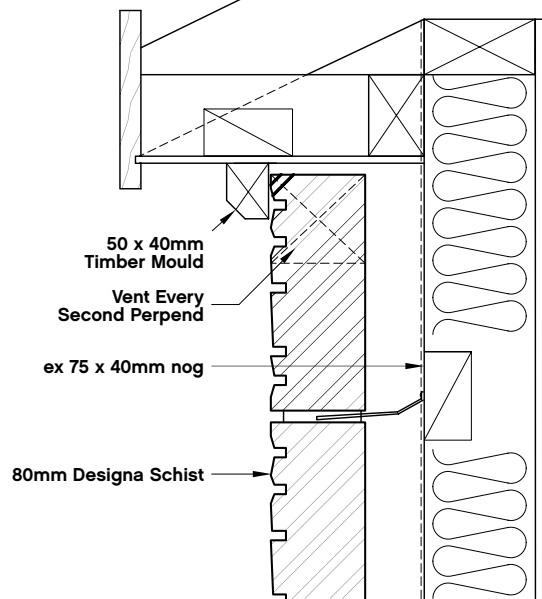

Fig. 4 Designa Schist  
- Flat Soffit & 150mm Frieze Board

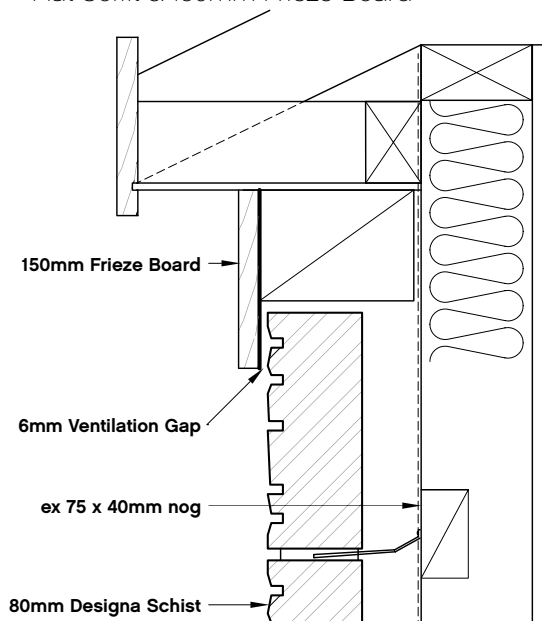
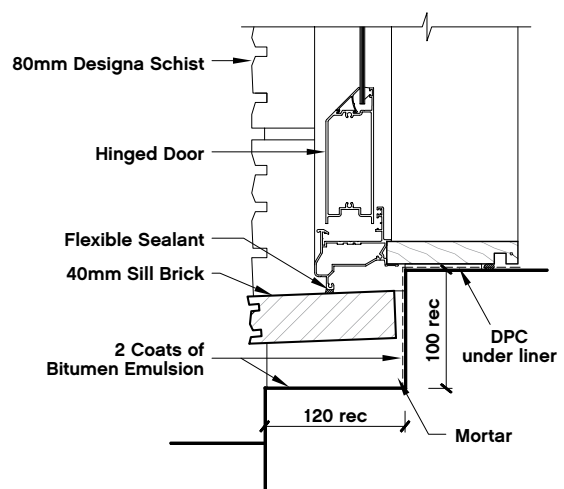

Fig. 5 Designa Schist  
- Brick Door Sill



**Note:**

If sill brick is to be sloped further if necessary either increase the depth of the step or reduce the thickness of the brick. Coat with water repellent sealer.

# 5.0 Technical Details

Fig. 6 Designa Schist  
- Window Head - Aluminium - Option 1

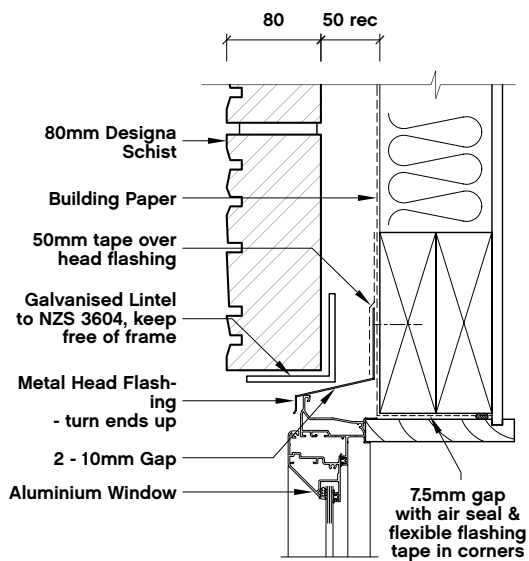

Fig. 7 Designa Schist  
- Window Head - Aluminium - Option 2

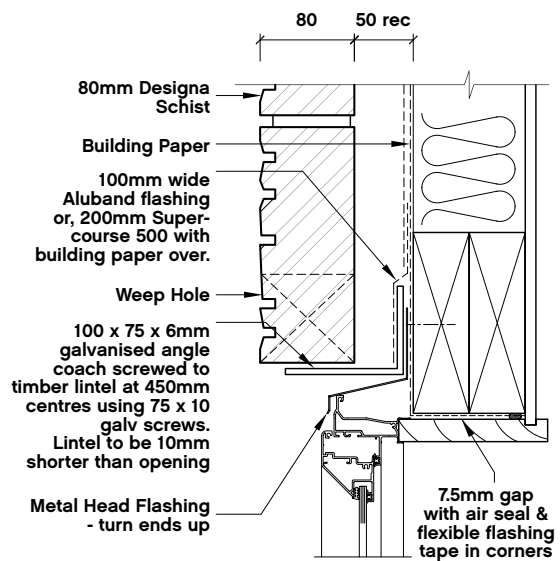

Fig. 8 Designa Schist  
- Window Sill - Aluminium

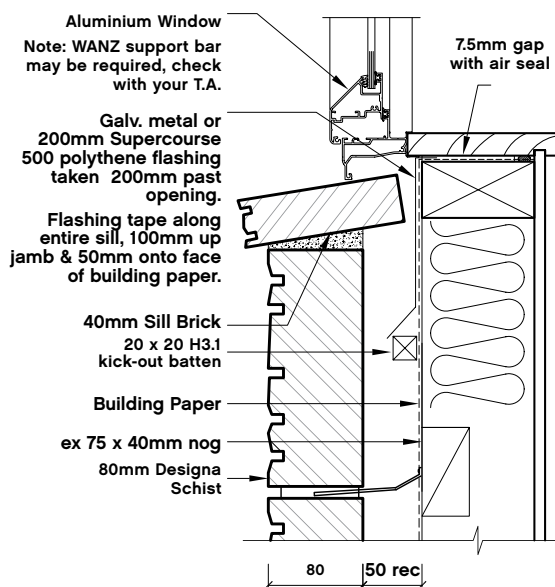
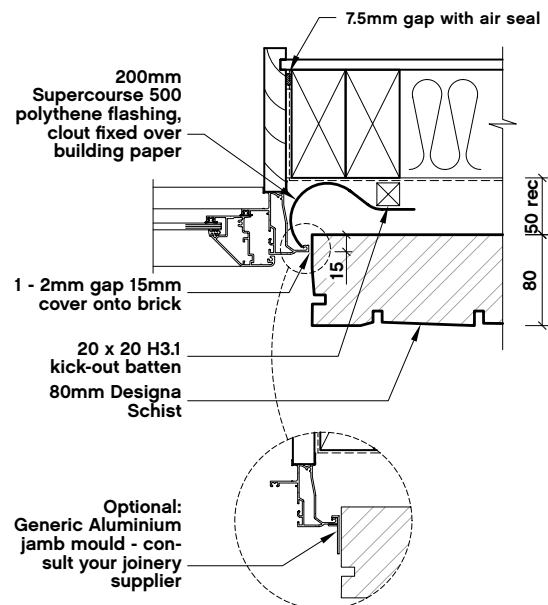

Fig. 9 Designa Schist  
- Window Jamb - Aluminium



# 5.0 Technical Details

Fig. 10 Designa Schist - Deep Reveal Window Jamb - Using Packer

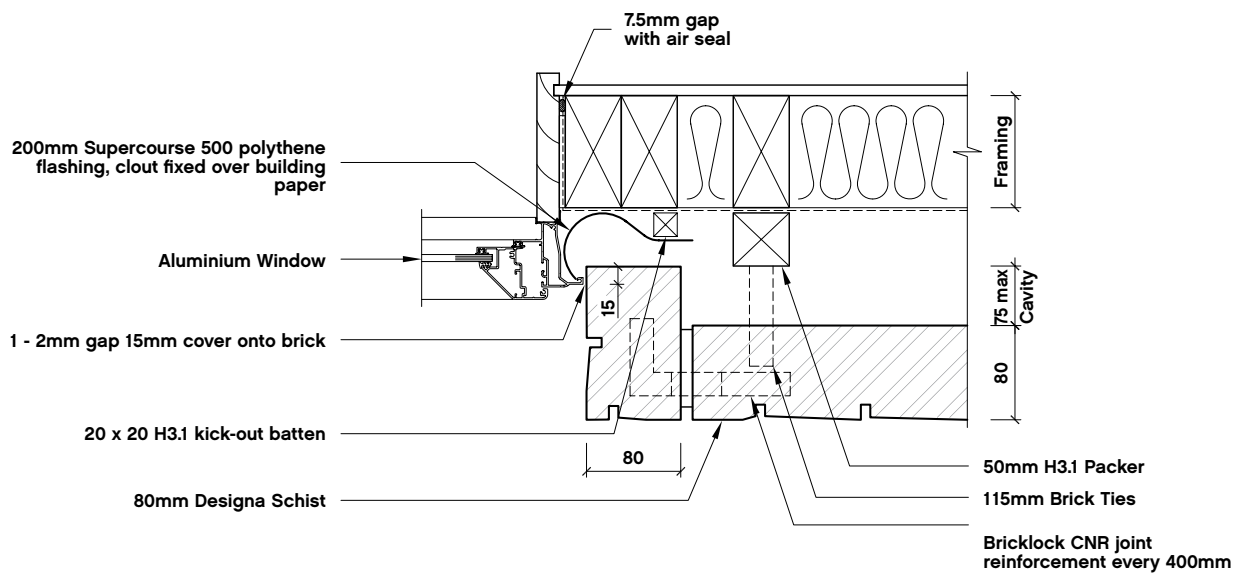
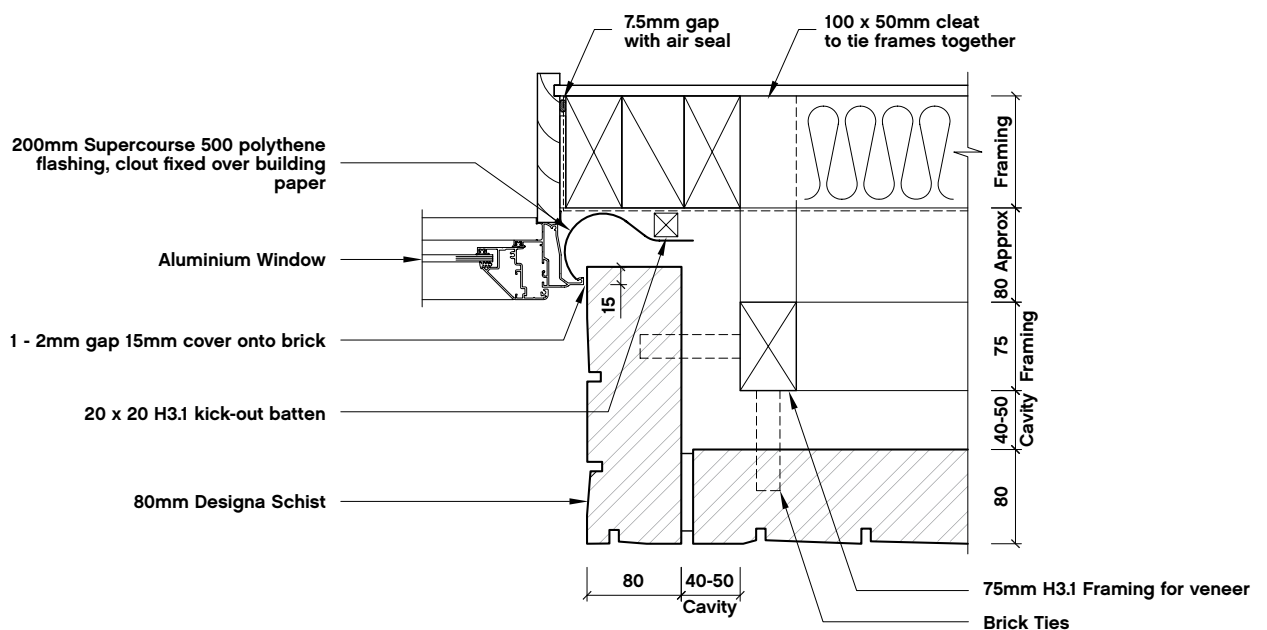
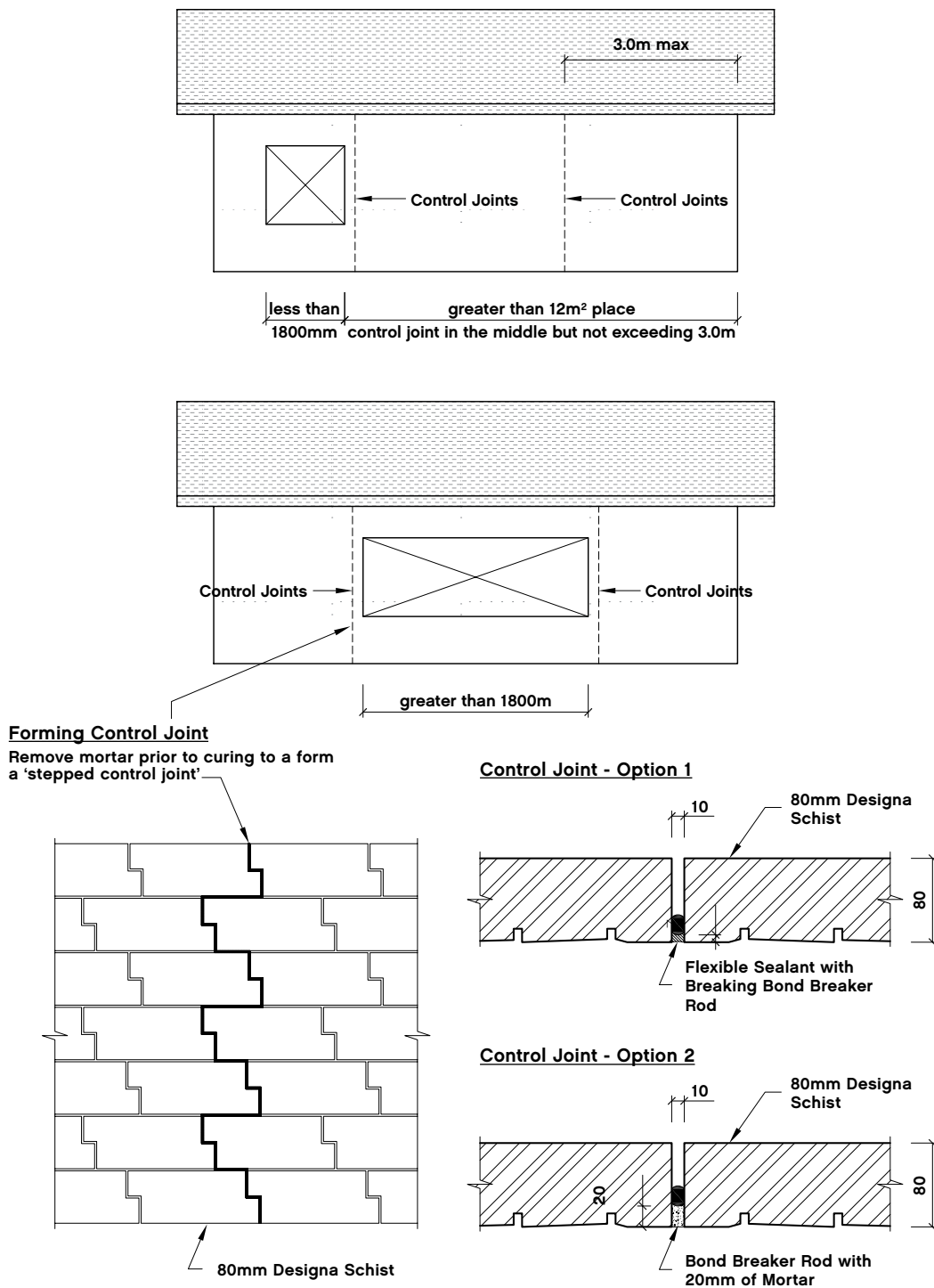

Fig. 11 Designa Schist - Deep Reveal Window Jamb - Double Stud Framing



# 5.0 Technical Details

Fig. 12 Designa Schist - Control Joints



# 5.0

## Technical Details

Fig. 13 Designa Schist - Columns (Using 450 & 600mm Z Bricks)

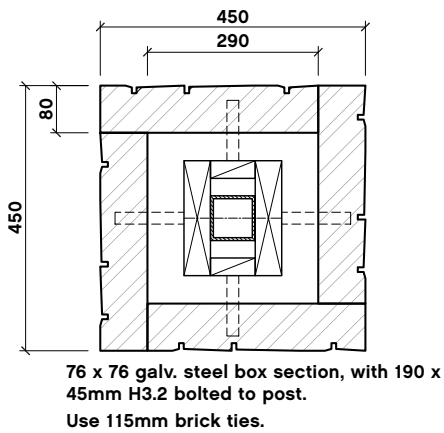
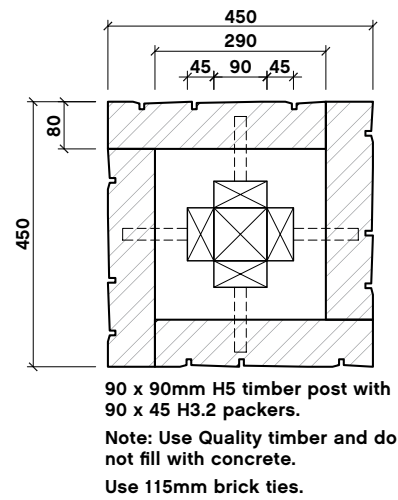
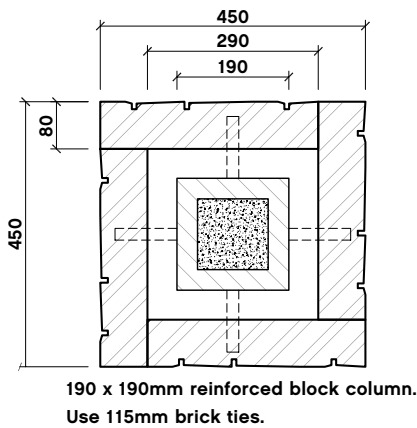

**Note:**

- Install weep holes on two opposing sides at the base.
- Cavity not to exceed 75mm for 115mm brick ties.
- Do not fill these columns with concrete.
- Fix brick ties into concrete using rawl plug MH56MMSS 5 x 38mm spike.

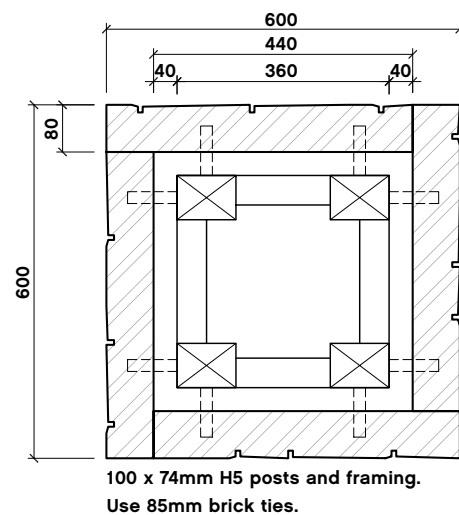
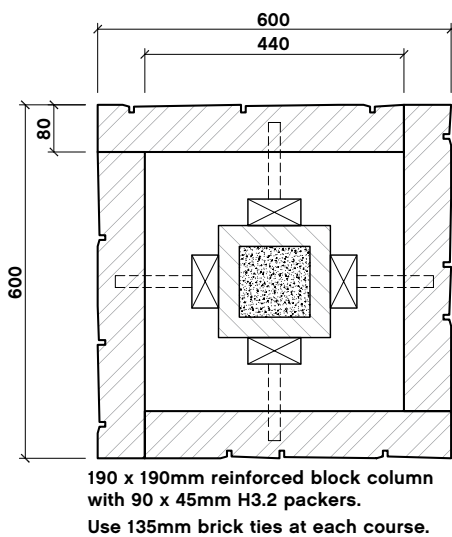



# 5.0

## Technical Details

Fig. 13A Designa Schist - Columns (Using 450 & 600mm Z Bricks)

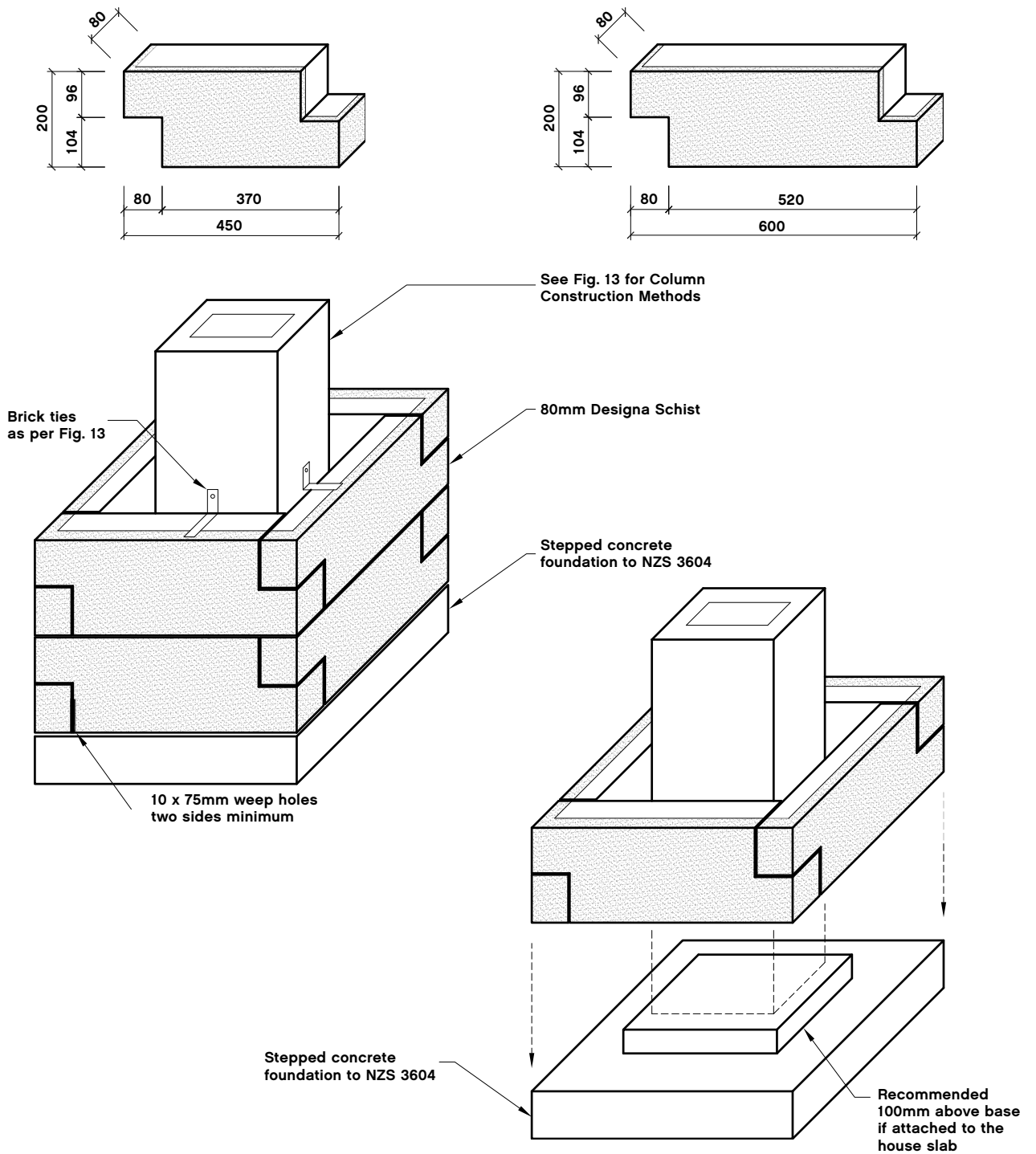

# 5.0 Technical Details

Fig. 14 Designa Schist - Corner Construction

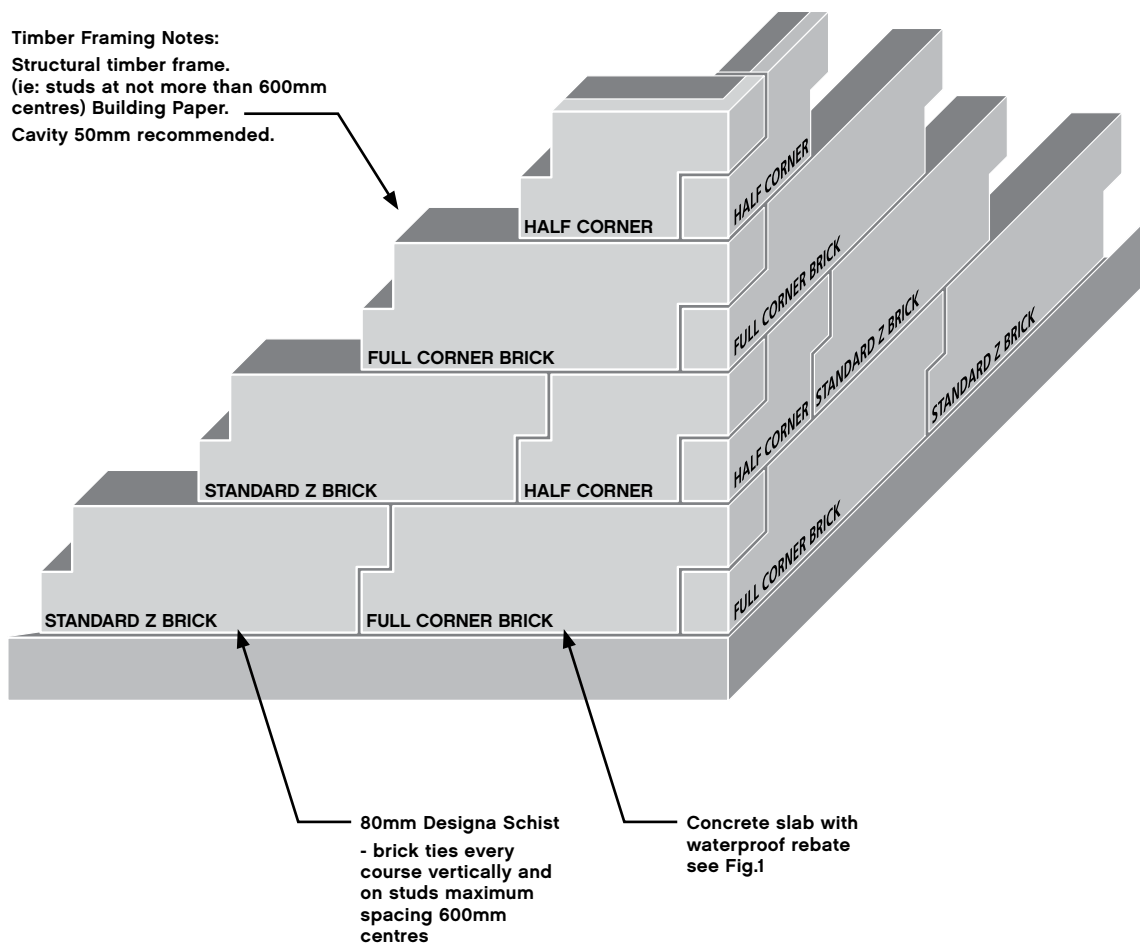

**Note:**

Where Designa Schist bricks do not perfectly meet along walls or between openings, the bricks are to be cut to the Z shape using a diamond saw.

# 6.0

## Producer Statement

---

### Designa Schist

#### **Compliance to the New Zealand Building Code**

Austral Bricks "Designa Schist" is a natural stone product for use as an external cladding material for homes. Designa Schist is a natural stone product that is manufactured to AS/NZS 4455.1 Masonry Units. As such Designa Schist is a masonry veneer cladding material that complies with the NZBC.

As a masonry veneer Designa Schist is suitable for use with timber framing constructed on slab-on-ground in accordance with NZS 3604 and/ or concrete masonry foundations constructed in accordance with NZS 4229. For steel framed structures the NASH (National Association of Steel Housing) Standard - *Residential and Low-rise Steel Framing Part 1: Design Criteria* is called up as a verification method under B1 Structure.

Designa Schist meets the requirements of NZBC Clause B2 for durability, based on the service history of masonry units in veneer construction using a drained and vented cavity.

Designa Schist must be installed in accordance with NZS 4210 Masonry Materials and Workmanship. The veneer cladding is required to be installed using EM (Earthquake Medium) galvanized screw fixed brick ties. Ties are to be installed every 200mm vertically and 600mm horizontally and must be embedded a minimum of 40mm into the mortar bed.

Austral Bricks warrants that its products are manufactured in accordance with the New Zealand legislative requirements namely that they are fit for purpose and of merchantable quality. Please refer to our terms of trade regarding the extent of Austral Bricks liability pursuant to this warranty.

Should you have any questions, please do not hesitate to contact NZ Brick Distributors for more information.