

VETRALLA QUARRYCAST FREESTANDING BATH 1500 X 731 X 548

victoria ⊕ albert[®]

52094.10
\$2799.00

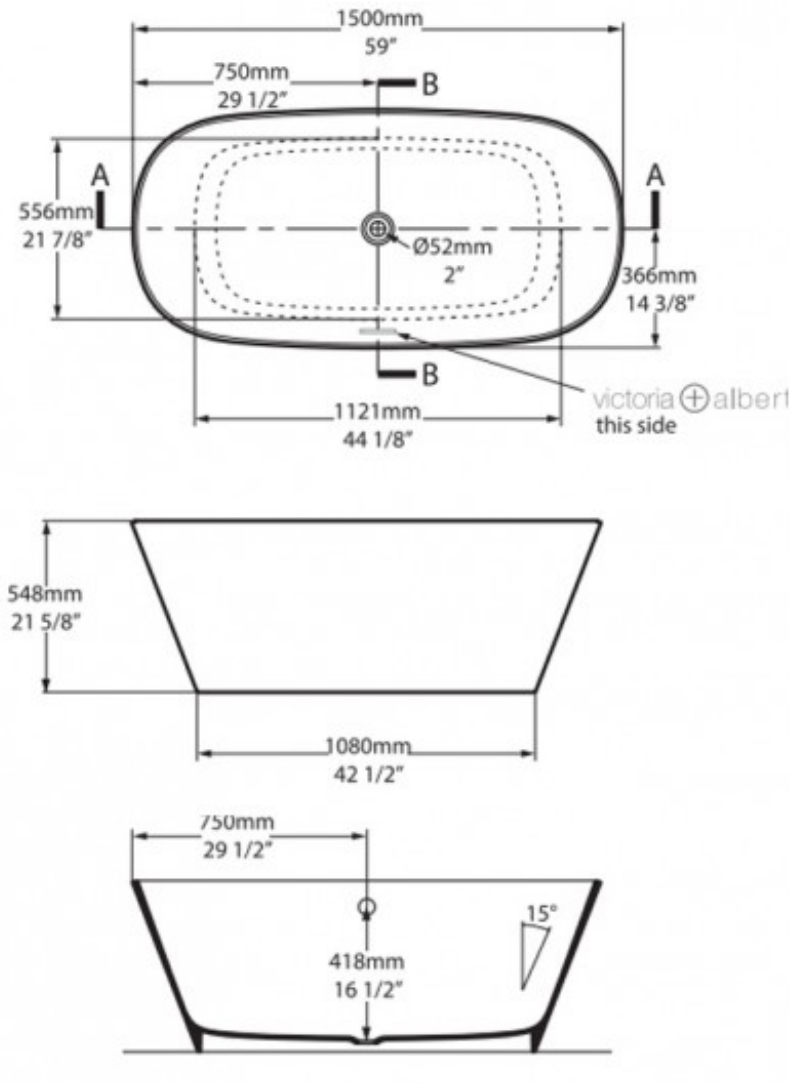

25

Guarantee

25 Year Guarantee



Residential/Light Commercial

Suitable for Residential/Light Commercial Use (Kitchens, Bathrooms and Laundries in Motels, Hotels and Retirement Villages)



Commercial Use

Suitable for commercial use.



Outdoor Use

Can be installed inside or outdoors.



Quarrycast

QUARRRYCAST[®] material is made from a finely ground volcanic limestone and resin mix. 100% one piece, hand finished and packed with naturally desirable properties.



Exterior Painting

Exterior can be painted or personalised.



Weight

67KG





Cleaning
Recommendations

We recommend any non-abrasive bathroom or kitchen cleaner however care should be taken with some products as they can damage the metal drain parts inside the bath. Abrasive cleaning products will cause the disappearance of the gloss finish over time.



British owned and
operated



Made in South Africa

Simple, deep and double-ended – ideal for modern bathrooms where space is at a premium. Also offered in a larger format called Vetralla 2. Available in 2 sizes.