

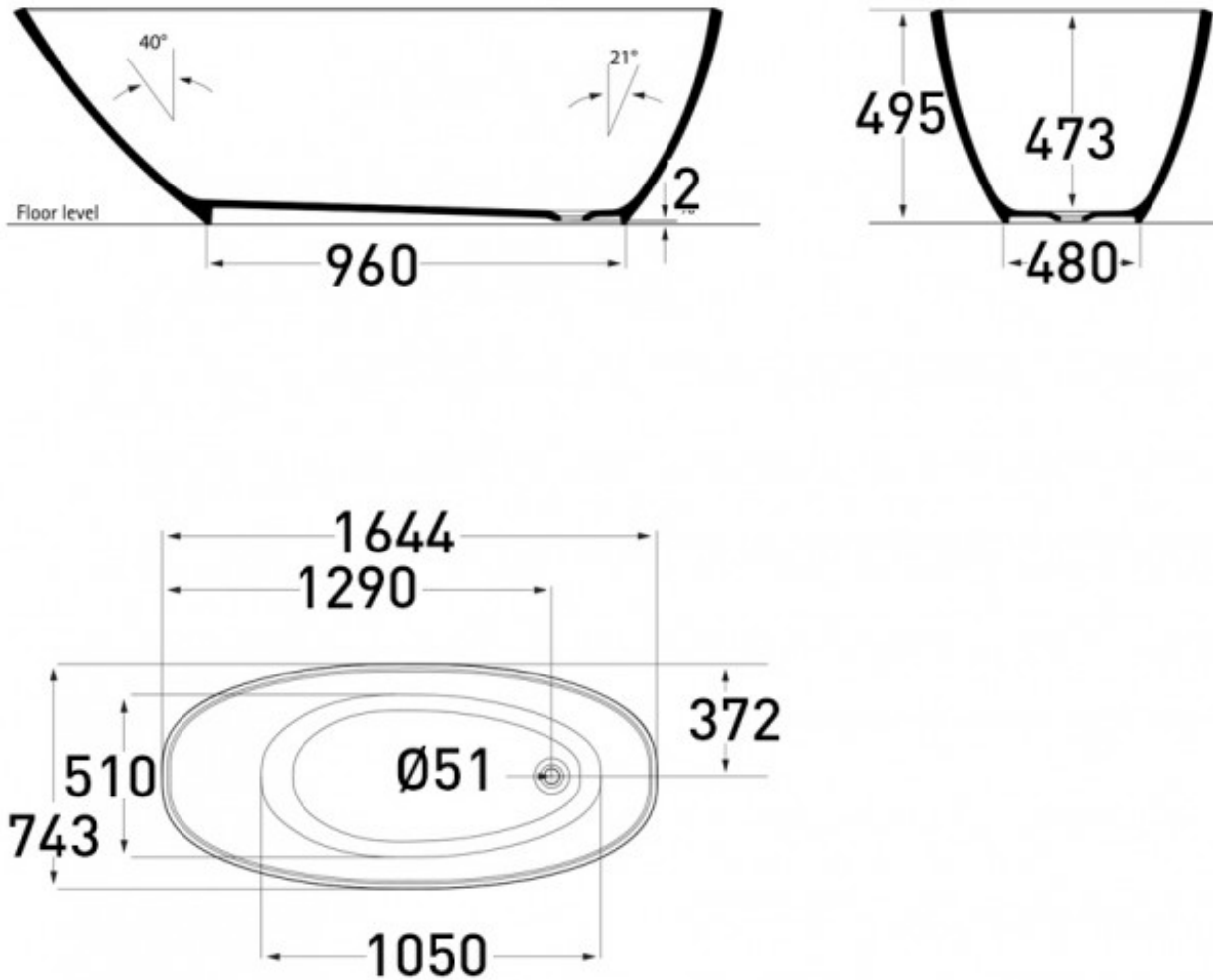







MOZZANO QUARRYCAST FREESTANDING BATH 1644 X 743 X 495

victoria ⊕ albert[®]

52066.10
\$5775.00



	Guarantee	25 Year Guarantee
	Dimensions	1644 (L) x 743 (W) x 495 (H)mm
	Residential Use	Suitable for Residential/Light Commercial Use (Kitchens, Bathrooms and Laundries in Motels, Hotels and Retirement Villages)
	Commercial Use	Suitable for commercial use.
	Capacity	250 Litres
	Outdoor Use	Can be installed inside or outdoors.
	Quarrycast	QUARRYCAST [®] material is made from a finely ground volcanic limestone and resin mix. 100% one piece, hand finished and packed with naturally desirable properties.





Exterior Painting

Exterior can be painted or personalised.



Weight

65KG



Cleaning
Recommendations

We recommend any non-abrasive bathroom or kitchen cleaner however care should be taken with some products as they can damage the metal drain parts inside the bath. Abrasive cleaning products will cause the disappearance of the gloss finish over time.



British owned and
operated



Made in South Africa

A beautifully crafted rimless freestanding bath, designed with confident curves and ergonomic design, Mozzano delivers a strong architectural presence in compact bathroom spaces.