

EDGE QUARRYCAST FREESTANDING BATH 1495 X 803 X 600

victoria ⊕ albert<sup>®</sup>

52082.10  
\$8315.00

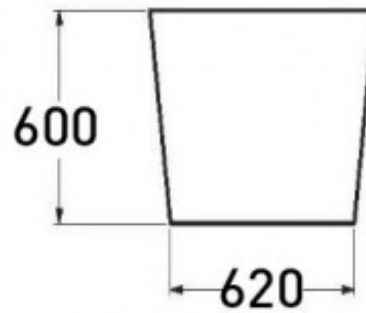
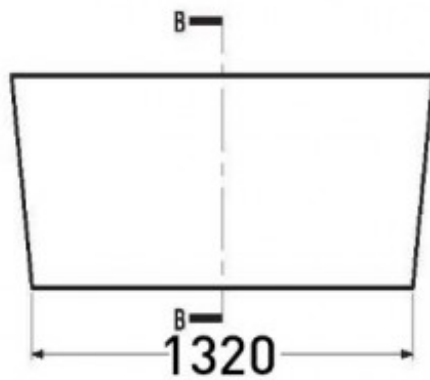
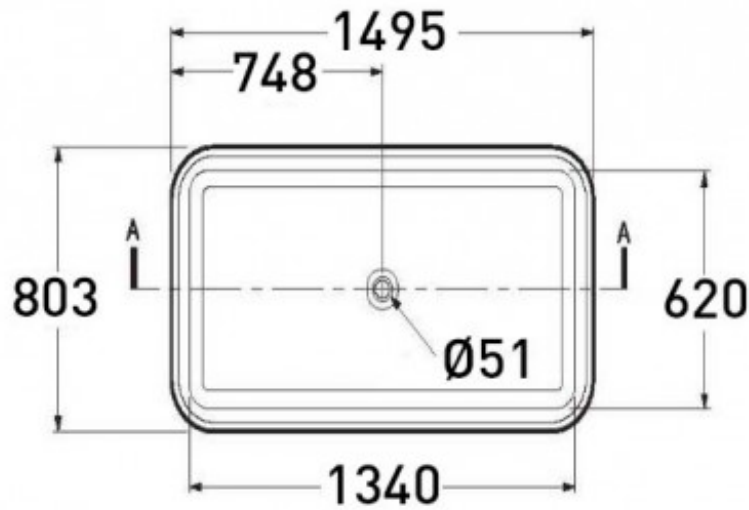

	Guarantee	25 Year Guarantee
	Dimensions	1495 (L) x 803 (W) x 600 (H)mm
	Residential Use	Suitable for Residential/Light Commercial Use (Kitchens, Bathrooms and Laundries in Motels, Hotels and Retirement Villages)
	Commercial Use	Suitable for commercial use.
	Capacity	353 Litres
	Outdoor Use	Can be installed inside or outdoors.
	Quarrycast	QUARRYCAST <sup>®</sup> material is made from a finely ground volcanic limestone and resin mix. 100% one piece, hand finished and packed with naturally desirable properties.





Exterior Painting

Exterior can be painted or personalised.



Weight

85KG



British owned and  
operated



Made in South Africa

Deep, double ended luxury in a compact format. The Edge shares many of the qualities of the successful iOS, with the addition of distinctive cubic styling.