



Parex Industries Ltd.
5 Tolich Place, Henderson
Auckland, New Zealand 0610
Sales/Service Tel: 0800 200 510
Email: info.parex@emerson.co.nz
www.insinkerator.co.nz

InSinkErator
471 Mountain Highway
Bayswater Vic 3153, Australia
Sales/Service Tel: 1300 136 205
Email: sales@insinkerator.com.au
www.insinkerator.com.au

InSinkErator
Emerson Electric Co.
4700 21st Street
Racine, WI 53406-5093
USA
Sales/Service Tel: 800-558-5700
www.insinkerator.com/worldmap.html

ISE
45212 REV C



The Emerson logo is a trademark and a service mark of Emerson Electric Co.
InSinkErator may make improvements and/or changes in the specifications at any time, in its sole discretion,
without notice or obligation, and further reserves the right to change or discontinue models.
©2017 InSinkErator, InSinkErator a business unit of Emerson Electric Co. All Rights Reserved.



multitap

ALL-IN-ONE TAP

Installation, Care & Use



F-H3N1GDZL-3
F-H3N1GDZJ-3
F-H3N1GDZU-3



WHAT YOU SHOULD KNOW BEFORE YOU BEGIN

- Please refer to the Installation, Care & Use manual packaged with your hot water tank and filtration system for additional **Important Safety Information** and installation instructions.

 For your satisfaction and safety, read all instructions, cautions and warnings before installing or using this tap.

- This particular unit is not for commercial/industrial use.

SYSTEM REQUIREMENTS (HOT WATER TANK, FILTRATION SYSTEM AND TAP):

- Make sure that all electrical, plumbing and connections conform to local codes.
- A standard, earthed (grounded) electrical outlet, with continuous supplied power, is required under the sink for the tank.
- This outlet must be fused and should not be controlled by the same wall switch that operates the disposer, unless you have a SinkTop Switch™ from InSinkErator®. Fuse/circuit breaker required is 10 amp for 230 or 220-240 volt and 15 amp for 120 volt.
- In Australia and New Zealand, all plumbing and electrical work must be completed by a qualified tradesperson. The installation must conform to AS/NZS3500.4 and AS/NZS3000.
- Do not install the filter on hot water supply lines. The maximum operating water temperature of this system is 38°C (100°F). Attach the filter to the cold water supply only.
- The hot water supply should not exceed 65°C (149°F)
- It is recommended that a dedicated control valve be installed on the cold water line supplying water to the filter system.
- To prevent damage or unit not operating properly, the water pressure must be between 210 kPa -860 kPa (2.1 bar - 8.6 bar; 30 psi - 125 psi). Ambient (room) temperature between 4°C (40°F) and 43°C (110°F).
- Do not install if water pressure exceeds 860 kPa (125 psi). If your water pressure exceeds 550 kPa (80 psi), you must install a pressure limiting valve. In Australia and New Zealand, a watermark certified AS/NZS2845.1 350 kPa (50 psi) set pressure limiting valve and dual check valve must be used.
- The use of a water filter should NOT result in the water pressure dropping below 210 kPa (30 psi).
- Do not install where water hammer conditions occur. If water hammer conditions exist you must install a water hammer arrester.
- The flexible vent and outlet tubes must be correctly connected to the tap supplied by the manufacturer. They must not be obstructed or connected to a normal type tap or any other type.
- Protect from freezing, shut off water supply, remove filter cartridge, drain hot water tank and tubing when temperatures are expected to drop below 4°C (40°F); see Seasonal Storage/Drainage section.
- Do not use a torch or other high temperature sources near system, cartridges, plastic fittings or plastic plumbing.
- Do not install near water pipes which will be in path of a drilling tool when selecting the position to mount the bracket.
- Mount system in such a position as to prevent it from being struck by other items used in the area of installation.
- Ensure that the location and fasteners will support the weight of the system when installed and full of water.
- When mounting tank and filter, screws provided are for use in wood studs or cabinets only. Use wall anchors (not supplied) for installation into plasterboard.
- Ensure all tubing and fittings are secure and free of leaks.
- Do not install using rigid piping. System intended for use with plastic water lines (such as PEX tubing, PE tubing, PP tubing).
- Do not install this system if any of the quick connect collets are missing from the filter head or Y-Quick Connector. Contact an authorized InSinkErator Service agent if collets are missing from any fittings.
- Important: Do not allow the unit to continuously boil.
- Regularly inspect the system. If there are signs of water leakage, turn off the water supply and contact an authorised InSinkErator Service agent.
- A drain pan, plumbed to an appropriate drain or outfitted with a leak detector, should be used in those applications where any leakage could cause property damage.
- If you suspect elevated levels of chlorine in your water, or your water has a rusty appearance before the installation of this unit, use of our water filtration system is recommended.
- This product contains stainless steel. The manufacturer cannot guarantee against rusty water because of the number of factors that are involved beyond the manufacturer's control. However, the sudden appearance of rusty water discharged from the hot water tap may indicate the need for service or replacement of this product.
- Moving parts inside the tank causing a rattling noise is normal.
- For questions or concerns, please contact an authorised InSinkErator Service agent (see back page for contact information).

ADDITIONAL CONSIDERATION WHEN UTILISING FILTRATION SYSTEM:

- The disposable filter cartridge MUST be replaced every 6 months, at the rated capacity or sooner if a noticeable reduction in flow rate occurs.
- Failure to replace the disposable filter cartridge at recommended intervals may lead to reduced filter performance and cracks in the filter housing, causing water leakage or flooding.
- Protect from freezing, remove filter cartridge when temperatures are expected to drop below 4°C (40°F).
- Do not install systems in areas where ambient temperatures may go above 43°C (110°F).
- Do not install in direct sunlight or outdoors.

WHAT YOU NEED TO GET STARTED

Equipment Required:



- Drill, T-fitting, Dedicated control valve, Adjustable spanner, Phillips screwdriver, Pencil, Tape measure, Level

Equipment You May Need:

- Anchors for plasterboard, Basin wrench, Tubing cutter, Hole Saw, Hole Punch

IMPORTANT SAFETY INFORMATION

Save these Instructions.

 WARNING	A potentially hazardous situation, which, if not avoided, could result in death or serious injury.
 CAUTION	A potentially hazardous situation, which, if not avoided, may result in minor or moderate injury.
NOTICE	Notice is used to address practices not related to personal injury.

- Use this water heater only for its intended use as described in this manual.
- This appliance can be used by children aged from 8 years and above and persons with reduced physical, sensory or mental capabilities or lack of experience and knowledge if they have been given supervision or instruction concerning use of the appliance in a safe way and understand the hazards involved. Children shall not play with the appliance. Cleaning and user maintenance shall not be made by children without supervision.
- Do not operate this product if it has been or appears to be damaged in any manner or after the product malfunctions, or is dropped. Return the complete product immediately to your retail dealer for inspection, and if necessary, adjustment or repair.
- If the supply cord is damaged, it must be replaced by the manufacturer, its service agent or similarly qualified persons in order to avoid a hazard.

 **WARNING:** To reduce the risk associated with choking: Do not allow children under 3 years of age to have access to small parts during the installation of this product.

 **WARNING: Electric Shock Hazard.** To reduce the risk of electric shock, do not immerse or expose the product, flexible cord or plug to rain, moisture or any liquid or when standing in or on damp or wet surfaces. If any electrical product falls into water, UNPLUG it immediately. DO NOT REACH INTO THE WATER. Important: Prior to reconnecting to the power supply, the product should be inspected by a qualified technician.

IMPORTANT SAFETY INFORMATION

 **WARNING: Personal Injury/Property Damage.** To reduce the risk associated with hazardous voltage due to an installer drilling through existing electric wiring in the area of installation: Do not install near electric wiring or water pipes which may be in path of a drilling tool when selecting the position to mount the system bracket.

Important: Always arrange the power cord so that it cannot come in contact with hot surfaces.

- Do not disconnect the product from the power supply by pulling on the cord.
- The use of accessory attachments other than those recommended by the manufacturer may cause safety hazards.
- The recommended connection may be made to an existing cold water line with a branch terminating with a shutoff valve, a pressure relief and dual check non-return valve sited adjacent to the product.

 **WARNING: Electric Shock Hazard** Using an ungrounded (no earth ground) or improperly connected appliance can result in serious injury or death from electrical shock.

This appliance must be earthed (grounded). This steaming hot water tank is equipped with a cord that has a grounding conductor and earth ground pin. The plug must be connected to an appropriate outlet that is properly installed and earthed (grounded) in accordance with all local codes and ordinances. Do not modify the plug provided with the appliance - if it will not fit the outlet, have a proper outlet installed by a qualified electrician. Check with a qualified electrician or tradesman if you are in doubt as to whether the steaming hot water tank is properly earthed (grounded).

 **CAUTION: Personal Injury/Property Damage.** This tank is a non-pressurised tank. DO NOT modify this system. DO NOT close vent tube or connect other types of taps or valves to the tank. Use only the InSinkErator tap supplied. Use only parts provided. Contact an authorised InSinkErator Service agent for repairs or replacement components.

 **WARNING:** To reduce the risk associated with the ingestion of contaminants: Do not use with water that is microbiologically unsafe or of unknown quality without adequate disinfection before or after the system.

A steaming hot water tank, like any water heater, has a limited life and will eventually fail. To avoid possible property damage and personal injury, this steaming hot water tank should be regularly examined for leakage and/or corrosion and replaced when necessary. A drain pan, plumbed to an appropriate drain or outfitted with a leak detector, should be used in those applications where any leakage could cause property damage.

 **WARNING: Fire Hazard.** To minimise possibility of fire, DO NOT store flammable items such as rags, paper or aerosol cans near the tank. DO NOT store or use petrol or other flammable vapours and liquids in the vicinity of this or any other appliance.

 **WARNING: Leak Hazard.** Regularly inspect tap and plumbing fittings for leaks, which can cause property damage and could result in personal injury.

 **NOTICE: Property Damage.** To reduce the risk associated with property damage due to water leakage or flooding, and to ensure optimal performance:

- Read and follow all instructions before installation and use of this system.
- Installation and use MUST comply with all state and local plumbing codes.

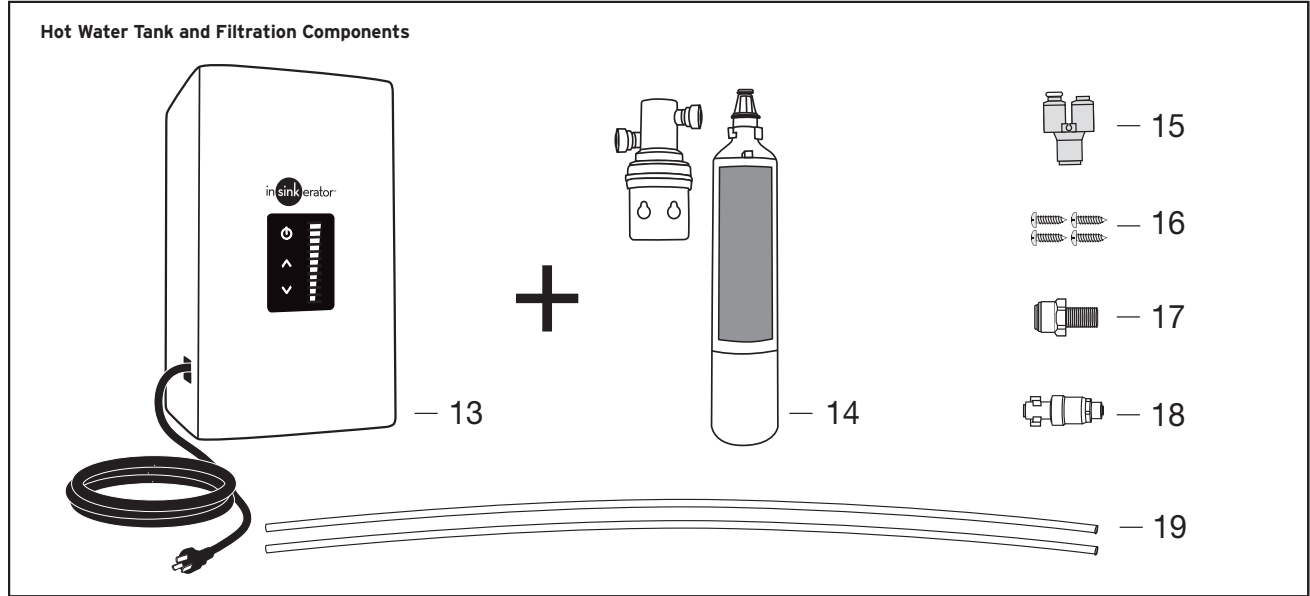
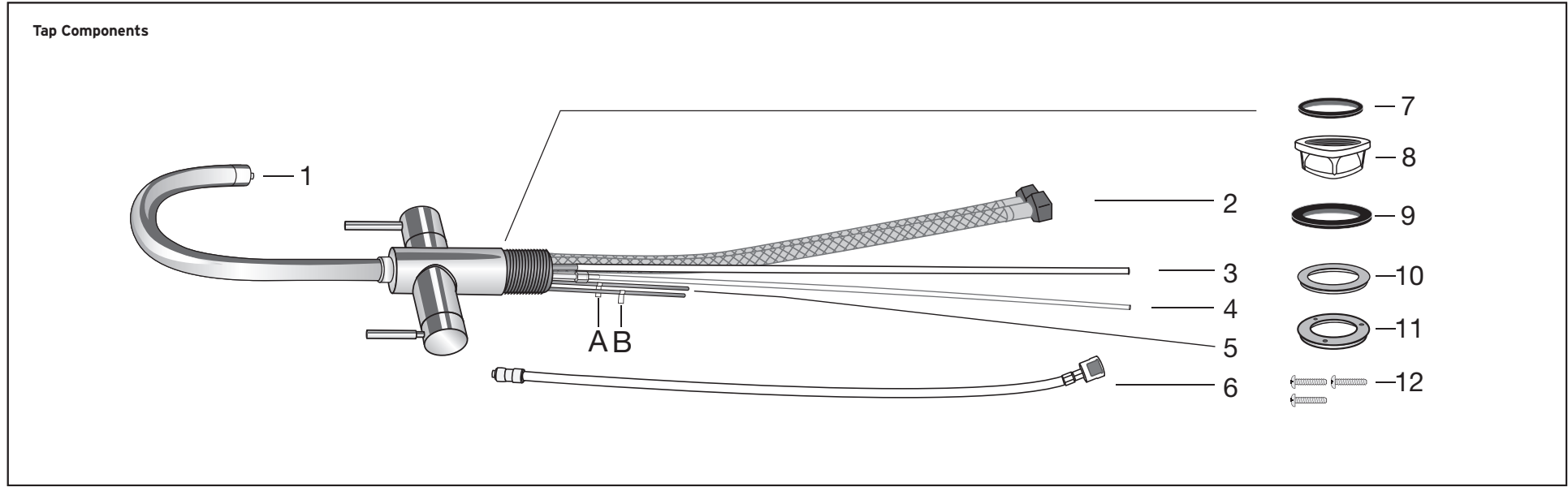

- PARTS**
- 1. All-in-One Tap
 - 2. Main Tap Cold/Hot Water Inlet Tubes
 - 3. White Hot Water Outlet Tube
 - 4. Clear Vent Tube
 - 5. Copper Tubes Labeled A and B
 - 6. White Aspirator Tube
 - 7. Small Rubber O-Ring
 - 8. Plastic Brace
 - 9. Large Rubber O-Ring
 - 10. Metal Ring
 - 11. Mounting Ring
 - 12. Mounting Screws (3)
 - 13. Hot Water Tank
 - 14. Filter Head and Cartridge
 - 15. Y-Quick Connector
 - 16. 19 mm (3/4") Screws (4)
 - 17. Connector and Fitting
 - 18. Back Flow Protection Valve
 - 19. Filter Tubes (2)

Overview of Complete Setup

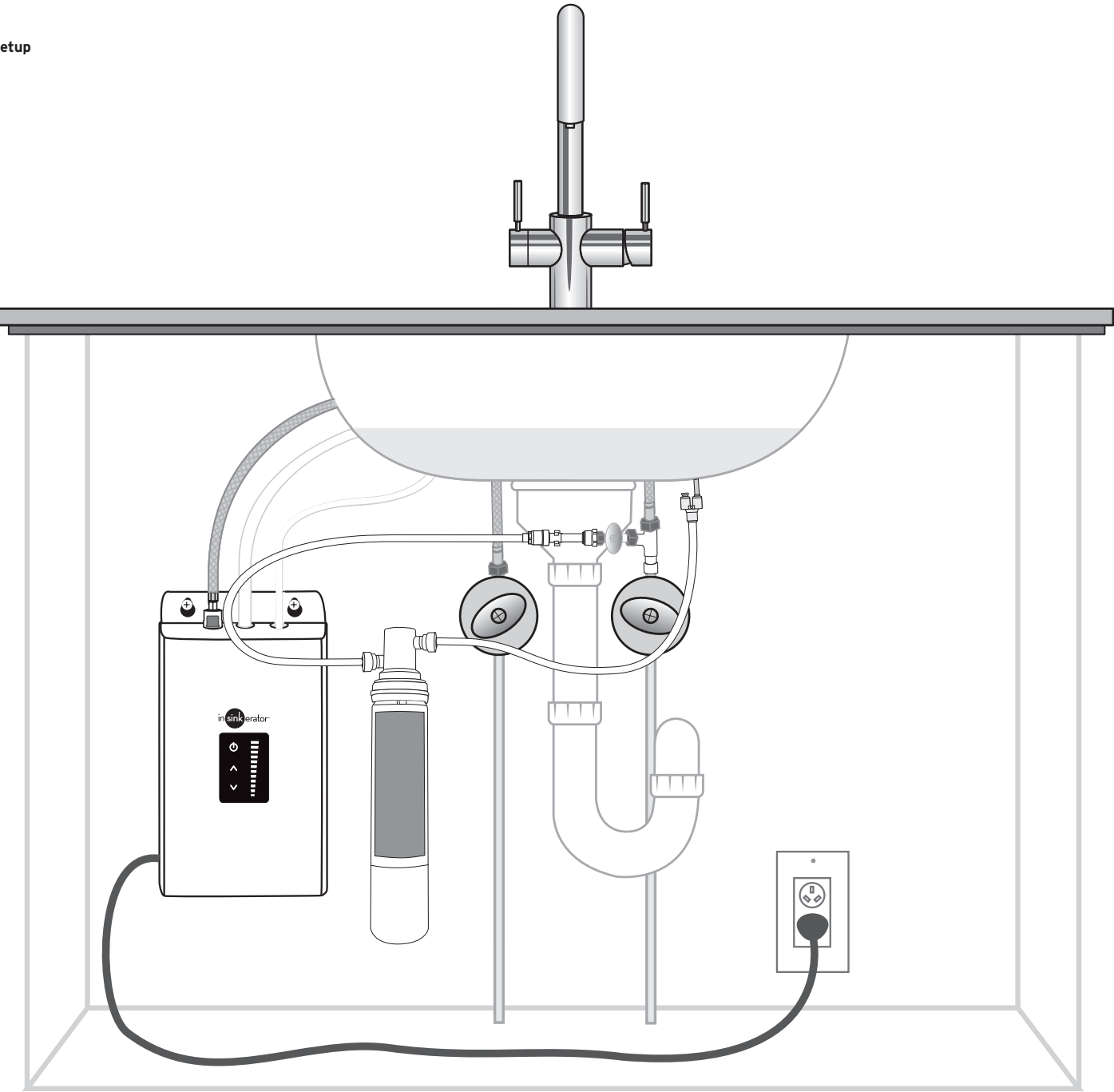

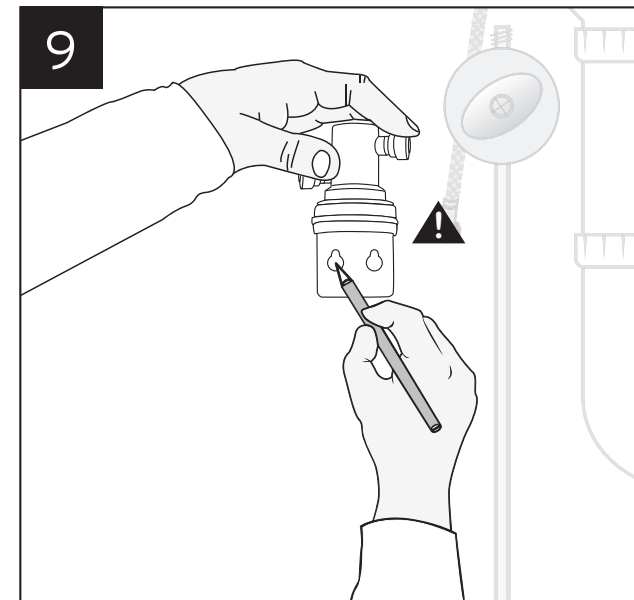
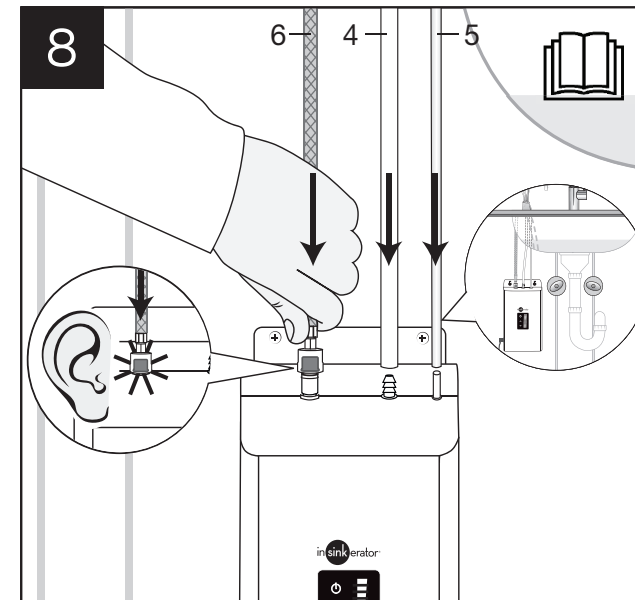
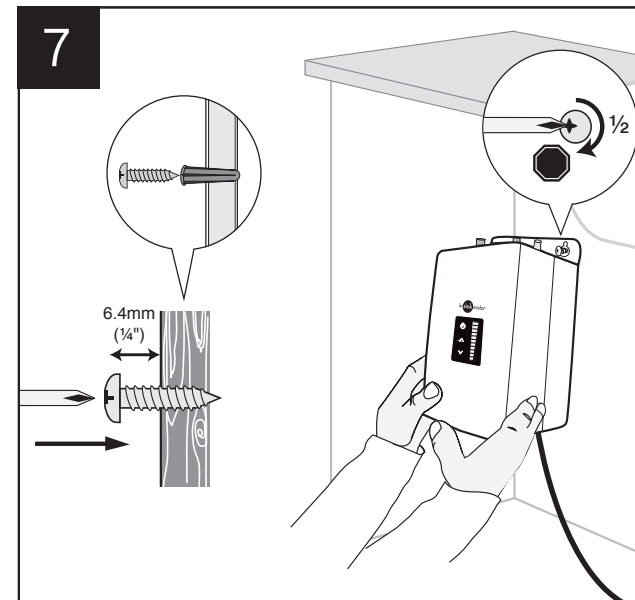
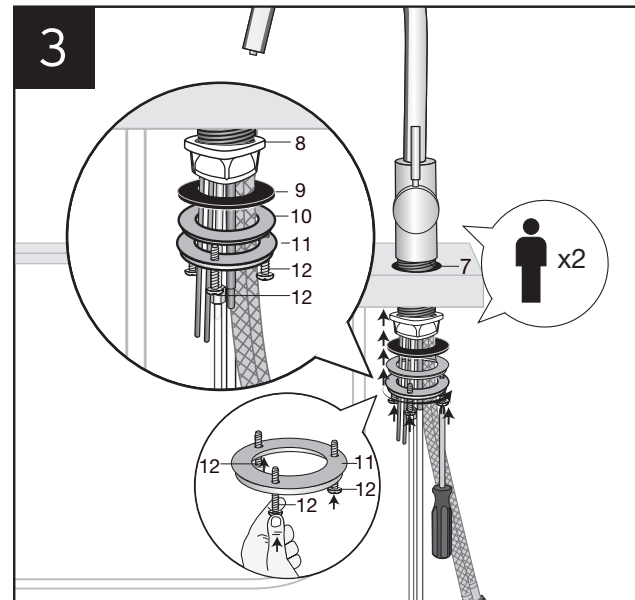
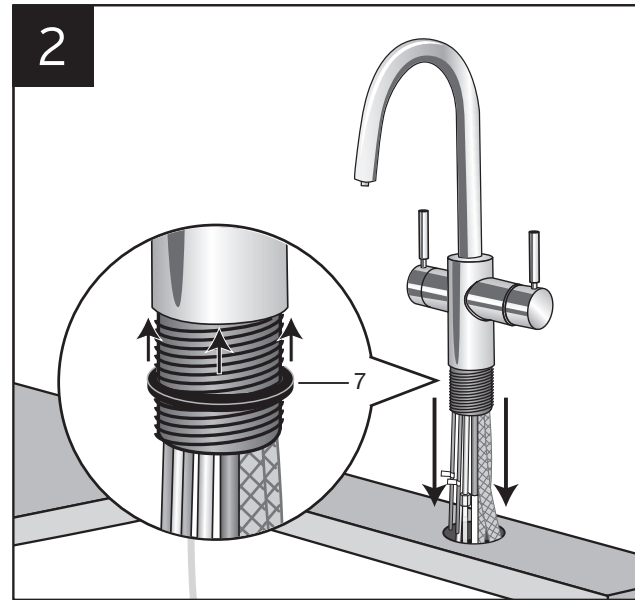
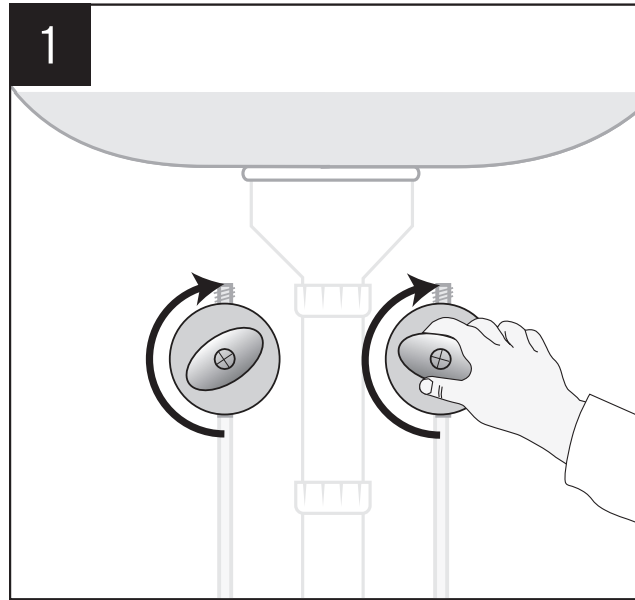

*** NOTICE: Property Damage.** Do not pinch or break copper tubing. Do not distort the last 25 mm (1") of tubing.
Note: Required 33.5 mm (1.3") hole size. For ease of installation put the braided hoses through first

*** NOTICE: Property Damage.** Pinched or blocked water lines may cause damage to the water tank. Check to make sure tubes are connected correctly and are pushed down as far as possible.

! WARNING. (Personal Injury) Do not locate filter above an outlet or other electrical device. Install head and bracket so that connections require no stretching, kinking or pinching of tubing.

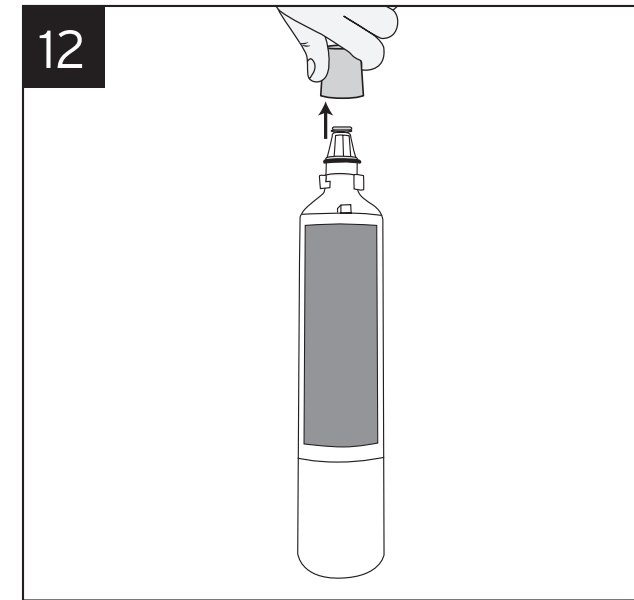
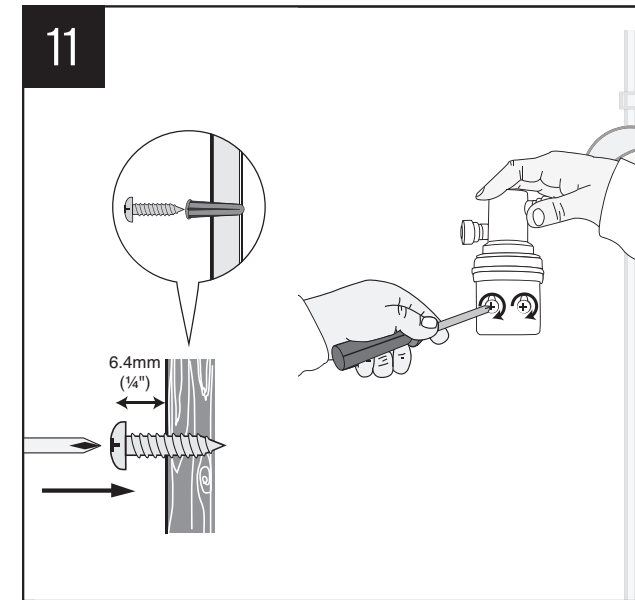
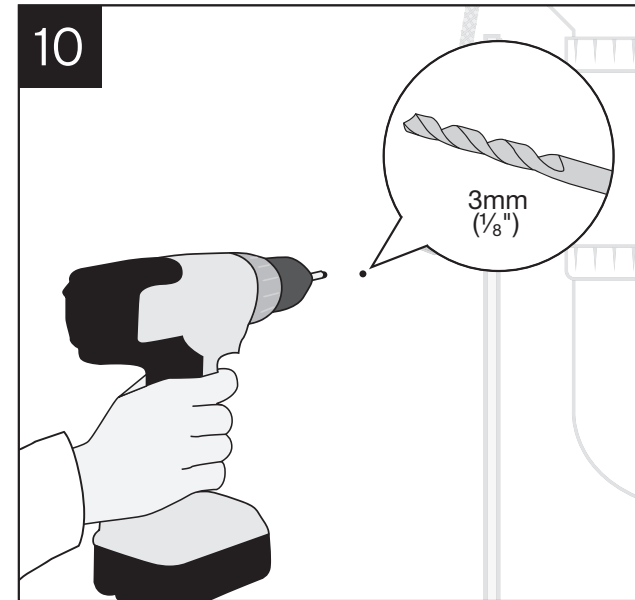
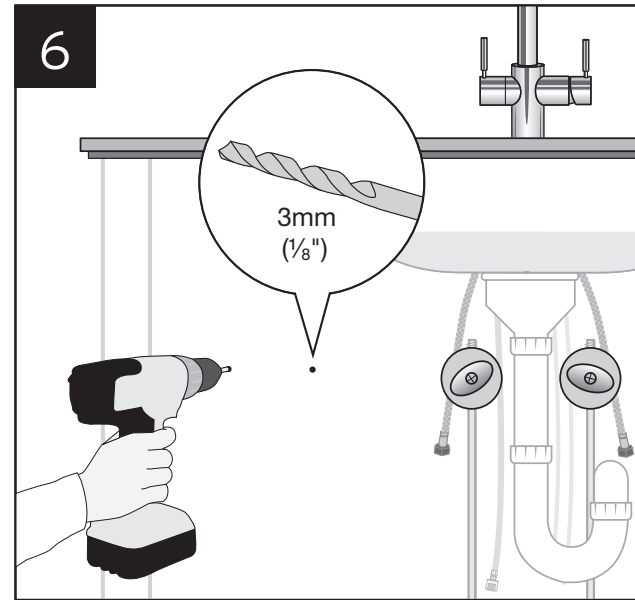
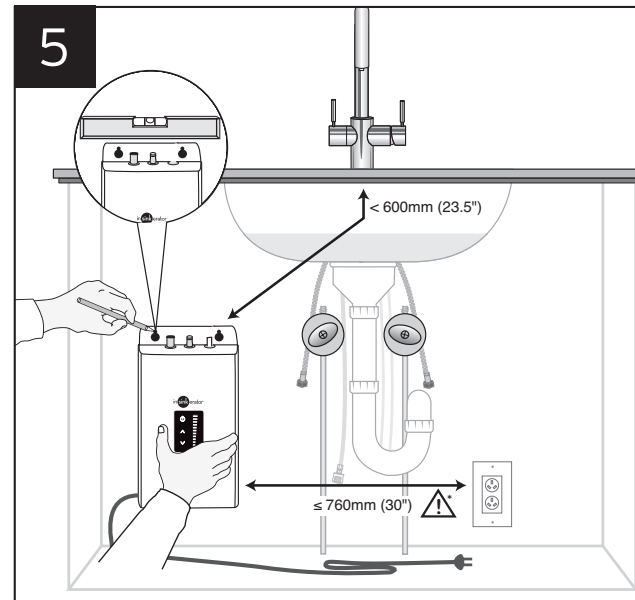
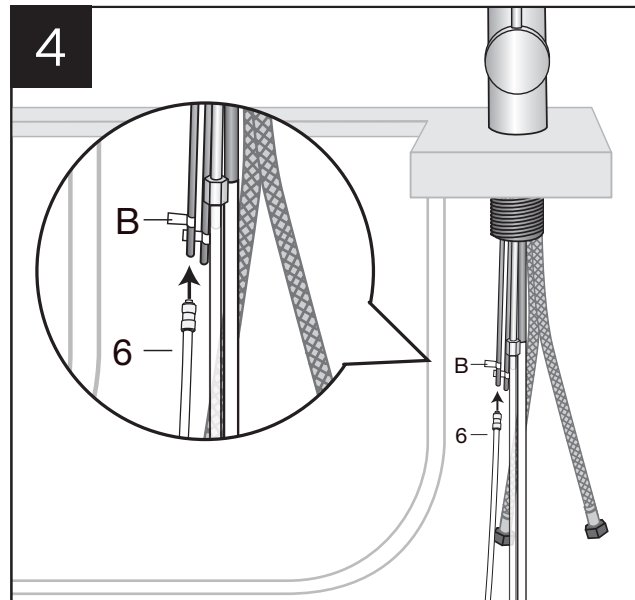

*** NOTICE: Property Damage.** Do not plug in hot water tank. Tank must be located within 600 mm (23.5") of tap and within 760 mm (30") or less of a standard earth (grounded) outlet. DO NOT extend plumbing or electrical lines.

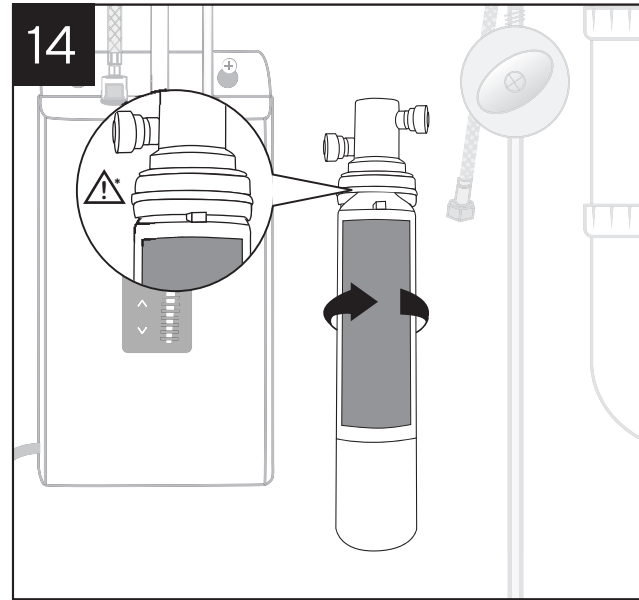
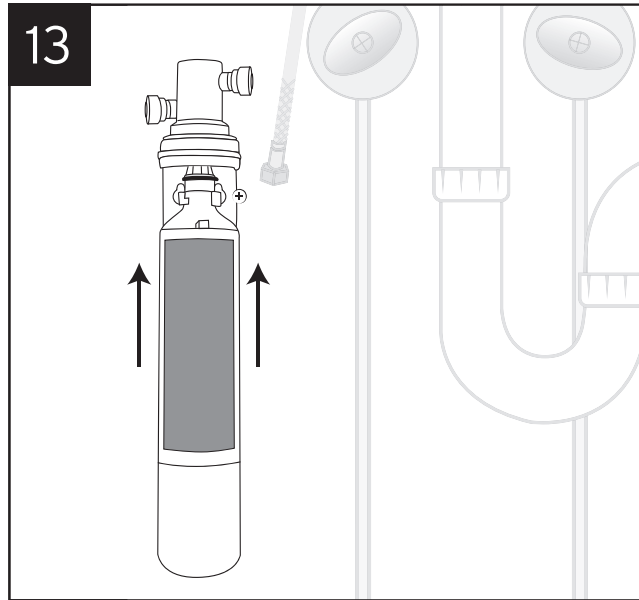

* **NOTICE: Property Damage.** Top surface of cartridge will be flush with bottom of filter head when fully engaged.

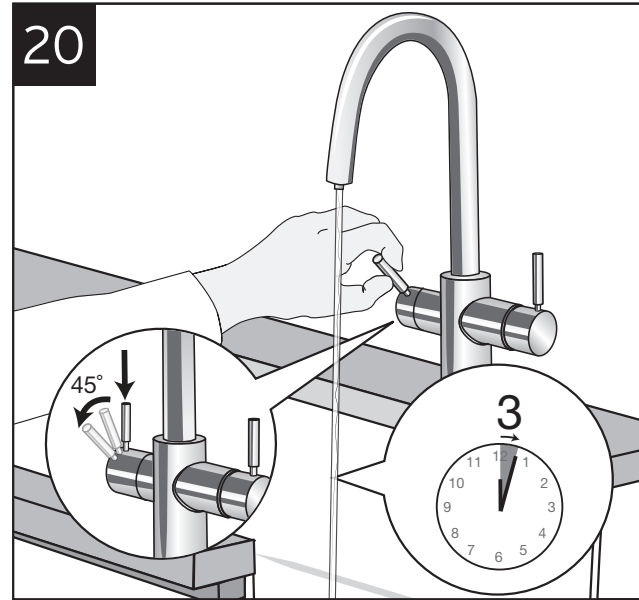
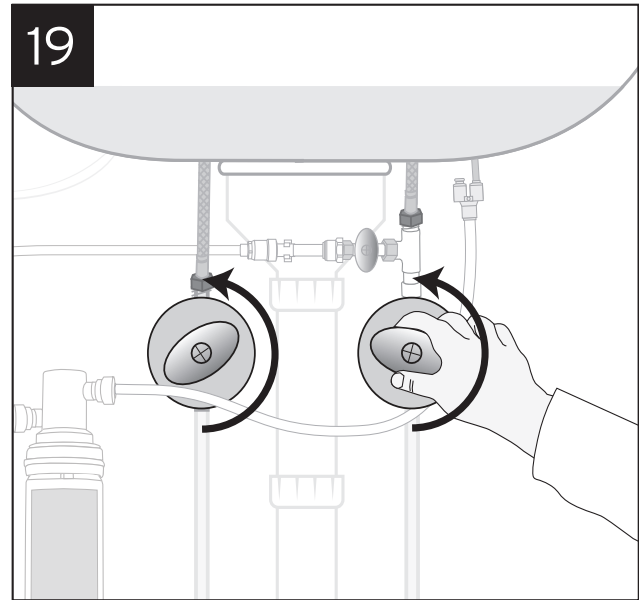
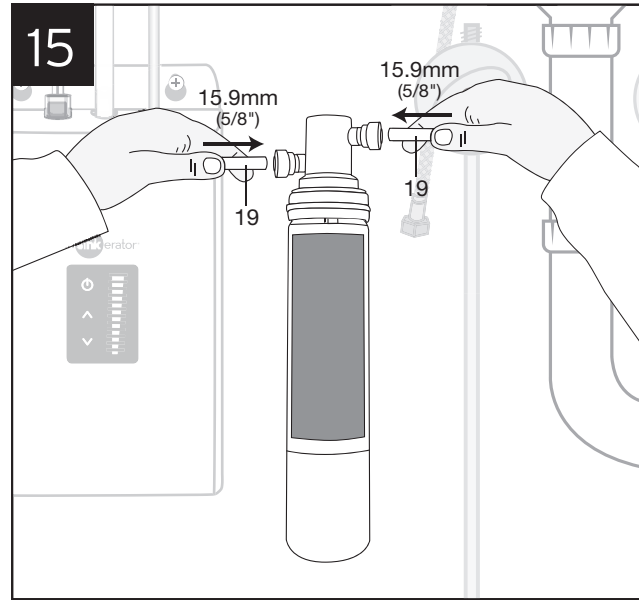

Note: Water will be cold at first. Allow 12-15 minutes for water to reach target temperature. Gurgling or hissing is normal during the initial heating cycle.

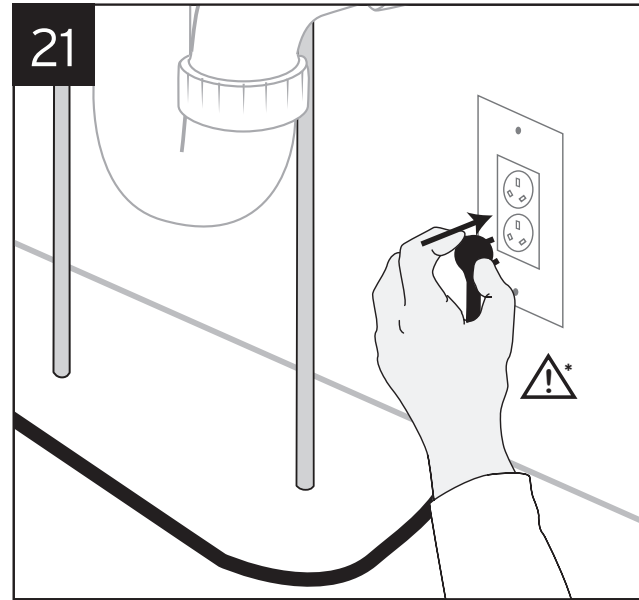

* **NOTICE: Property Damage.** Do not use an extension lead with the tap. (A standard earthed outlet within 760 mm (30") of the tap is required under the sink.)

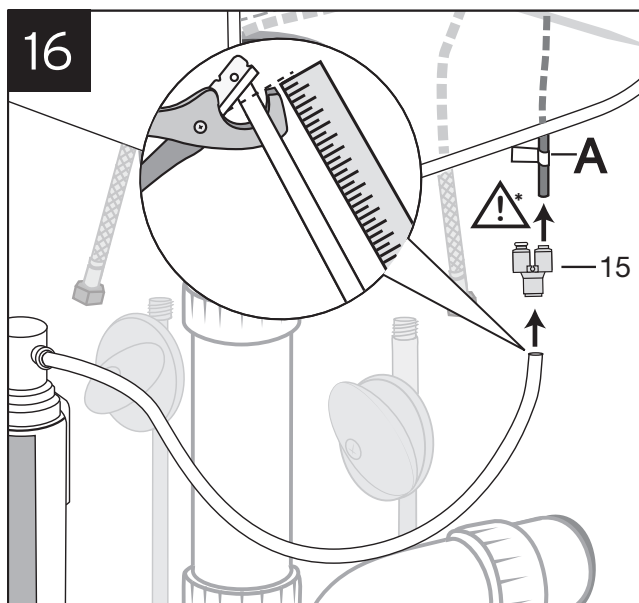

* **NOTICE: Property Damage.** Do not extend the lines farther than the 400 mm (16") provided. Ensure tube(s) and "Y" connector fit securely.

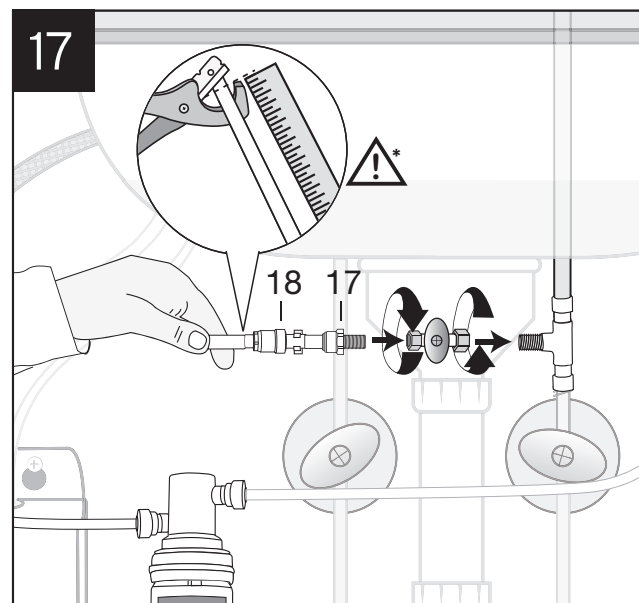

* **NOTICE: Property Damage.** Tube runs need to form to the cabinet's contours to allow storage space with no sharp bends. Tubes need clean, perpendicular, burr-free cuts to ensure a true fit. Join remaining tube to cold water supply only.

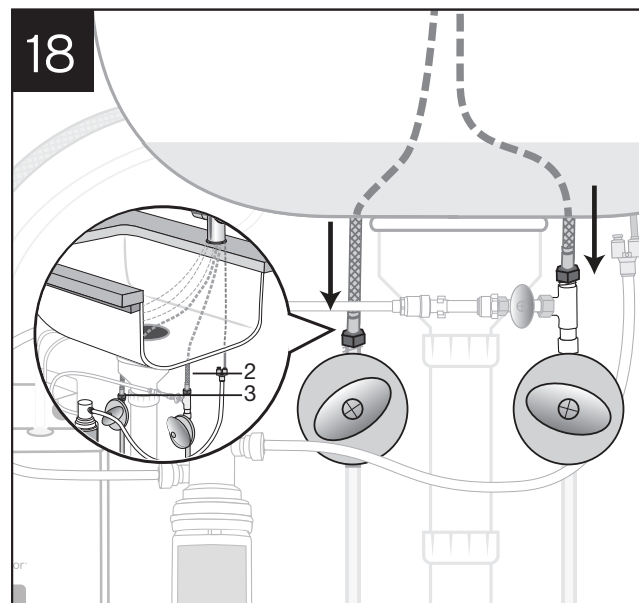

Note: Check all connections to ensure they are tight and that there are no leaks.

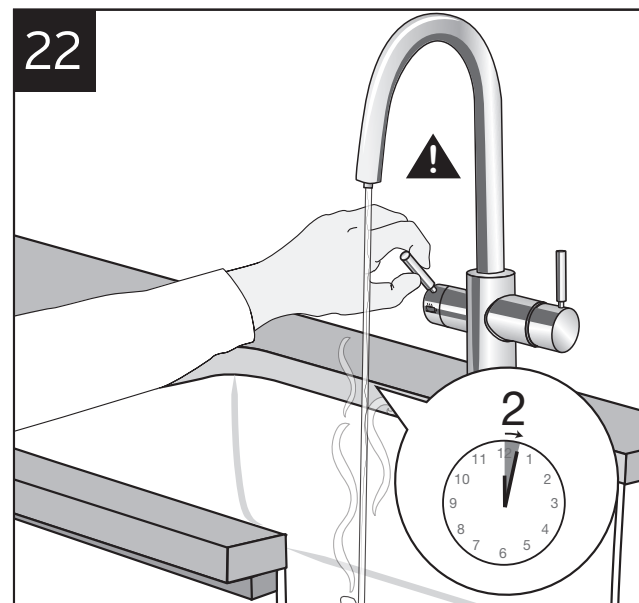

! WARNING: Scalding Hazard. The tap dispenses near-boiling water which can instantly cause scalds or burns. Use care when operating this appliance.

5-YEAR IN-HOME FULL SERVICE LIMITED WARRANTY

This limited warranty is provided by InSinkErator, a business unit of Emerson Electric Co., (“**InSinkErator**” or “**Manufacturer**” or “**we**” or “**our**” or “**us**”) to the original consumer owner of the InSinkErator product with which this limited warranty is provided (the “**InSinkErator Product**”), and any subsequent owner of the residence in which the InSinkErator Product was originally installed (“**Customer**” or “**you**” or “**your**”).

InSinkErator warrants to Customer that your InSinkErator Product will be free from defects in materials and workmanship, subject to the exclusions described below, for the “**Warranty Period**”, commencing on the later of: (a) the date your InSinkErator Product is originally installed, (b) the date of purchase, or (c) the date of manufacture as identified by your InSinkErator Product serial number. You will be required to show written documentation supporting (a) or (b). If you are unable to provide documentation supporting either (a) or (b), the Warranty Period commencement date will be determined by Manufacturer, in its sole and absolute discretion, based upon your InSinkErator Product serial number.

Permitted Uses

You may use your InSinkErator Product hot/cold water tank and filter system in combination with any genuine InSinkErator Product tap and component parts and/or Authorized OEM Products. “Authorized OEM Products” mean those hot or hot/cold water taps and component parts that have been manufactured by an authorized InSinkErator original equipment manufacturer (“Authorized OEM”) and which have documentation expressly stating that such Authorized OEM Products are compatible with the InSinkErator Product(s). Authorized OEMs may change from time to time. A list of Authorized OEMs is available to you upon request or at: www.insinkerator.com/oem. Use of your InSinkErator Product in combination with any products other than Authorized OEM Products will void this warranty.

What is Covered

This limited warranty covers defects in materials or workmanship, subject to the exclusions below, in InSinkErator Products used by a consumer Customer for residential use only, and includes all replacement parts and labor costs. **YOUR SOLE AND EXCLUSIVE REMEDY UNDER THIS LIMITED WARRANTY SHALL BE LIMITED TO REPAIR OR REPLACEMENT OF THE INSINKERATOR PRODUCT, PROVIDED THAT IF WE DETERMINE IN OUR SOLE DISCRETION THAT NEITHER REMEDY IS PRACTICABLE, WE MAY PROVIDE YOU A REFUND OF YOUR PURCHASE PRICE OR A CREDIT TOWARDS ANOTHER INSINKERATOR PRODUCT.**

What is not Covered

This limited warranty does not extend to and expressly excludes:

- Losses or damages or the inability to operate your InSinkErator Product resulting from conditions beyond the Manufacturer’s control including, without limitation, accident, alteration, misuse, abuse, neglect, negligence (other than Manufacturer’s), failure to install, maintain, assemble, or mount the InSinkErator Product in accordance with Manufacturer’s instructions or local electrical and plumbing codes.
- Wear and tear expected to occur during the normal course of use, including without limitation, cosmetic rust, scratches, dents or comparable and reasonably expected losses or damages.
- Losses or damages caused by any product or component part used with the InSinkErator Products, including both Authorized OEM Products and other products and components.

In addition to the above exclusions, this warranty does not apply to InSinkErator Products installed in a commercial or industrial application.

No Other Express Warranty Applies

This limited warranty is the sole and exclusive warranty provided to the Customer identified above. No other express warranty, written or verbal, applies. No employee, agent, dealer, or other person is authorized to alter this limited warranty or make any other warranty on behalf of Manufacturer. The terms of this limited warranty shall not be modified by the Manufacturer, the original owner, or their respective successors or assigns.

What we will do to Correct Problems

If your InSinkErator Product does not operate in accordance with the documentation provided to you, or you have questions concerning your InSinkErator Product or how to determine when service is needed please call the toll free InSinkErator Customer Service (**New Zealand:** 0800 200 510) or (**Australia:** 1300 136 205) or visit our website (**New Zealand:** www.insinkerator.co.nz) or (**Australia:** www.insinkerator.com.au). You may also notify us at: Parex Industries Ltd., 5 Tolich Place, Henderson, Auckland, New Zealand 0610 or InSinkErator, 471 Mountain Highway, Bayswater Vic 3153, Australia

The following information must be provided as part of your warranty claim: your name, address, phone number, your InSinkErator Product model and serial number, and if necessary, upon request, written confirmation of either: (a) the date shown on your installation receipt, or (b) the date shown on your purchase receipt.

Manufacturer or its authorized service representative will determine, in its sole and absolute discretion, if your InSinkErator Product is covered under this warranty. You will be given the contact information for your closest authorized InSinkErator Service Center. Please contact your InSinkErator Service Center directly to receive in home warranty repair or replacement service. Only an authorized InSinkErator service representative may provide warranty service. InSinkErator is not responsible for warranty claims arising from work performed on your InSinkErator Product by anyone other than an authorized InSinkErator service representative.

If a covered claim is made during the Warranty Period, Manufacturer will, through its authorized service representative, either repair or replace your InSinkErator Product. Cost of replacement parts or a new InSinkErator Product, and cost of labor for repair or installation of the replacement InSinkErator Product are provided at no cost to you. Repair or replacement shall be determined by Manufacturer or its authorized service representative in their sole discretion. All repair and replacement services will be provided to you at your home. If Manufacturer determines that your InSinkErator Product must be replaced rather than repaired, the warranty on the replacement InSinkErator Product will be limited to the unexpired term remaining in the original Warranty Period.

This tap is covered by Manufacturer’s limited warranty. This limited warranty is void if you attempt to repair the InSinkErator Product. For service information, please contact the Authorised InSinkErator Service Center for your area as identified on back cover of this manual.

Limitation of Liability

TO THE EXTENT PERMITTED BY LAW, IN NO EVENT SHALL MANUFACTURER OR ITS AUTHORIZED SERVICE REPRESENTATIVES BE LIABLE FOR ANY INCIDENTAL, SPECIAL, INDIRECT, OR CONSEQUENTIAL DAMAGES, INCLUDING ANY ECONOMIC LOSS, WHETHER RESULTING FROM NONPERFORMANCE, USE, MISUSE OR INABILITY TO USE THE INSINKERATOR PRODUCT OR THE MANUFACTURER’S OR ITS AUTHORIZED SERVICE REPRESENTATIVE’S NEGLIGENCE. MANUFACTURER SHALL NOT BE LIABLE FOR DAMAGES CAUSED BY DELAY IN PERFORMANCE AND IN NO EVENT, REGARDLESS OF THE FORM OF THE CLAIM OR CAUSE OF ACTION (WHETHER BASED IN CONTRACT, INFRINGEMENT, NEGLIGENCE, STRICT LIABILITY, OTHER TORT OR OTHERWISE), SHALL MANUFACTURER’S LIABILITY TO YOU EXCEED THE PRICE PAID BY THE ORIGINAL OWNER FOR THE INSINKERATOR PRODUCT.

The term “consequential damages” shall include, but not be limited to, loss of anticipated profits, business interruption, loss of use or revenue, cost of capital or loss or damage to property or equipment.

Some states do not allow the exclusion or limitation of incidental or consequential damages, so the above limitation may not apply to you. This limited warranty gives you specific legal rights and you may also have other rights which vary from state to state.

STEAMING HOT TAP TROUBLESHOOTING

PROBLEM	POSSIBLE CAUSE	WHAT TO DO
Water and steam spits forcefully from spout without turning on the tap.	<ul style="list-style-type: none"> • Unit is boiling. <i>May be normal during initial set-up.</i> 	<ul style="list-style-type: none"> • Firmly grasp and twist hot water tap handle while pressing down activator button to release some water from the tank. • Adjust water temperature using dial on tank front. • Remember that at higher altitudes, water boils at lower temperatures.
Water is not hot.	<ul style="list-style-type: none"> • The unit is unplugged. • The electric outlet is inoperative. 	<ul style="list-style-type: none"> • Make sure the unit is connected to a correctly earthed electric outlet. • Make sure the circuit breaker or fuses are functioning correctly. • Check that the outlet is not switched off.
Water is too hot or not hot enough.	<ul style="list-style-type: none"> • Thermostat is not adjusted to your needs. 	<ul style="list-style-type: none"> • Adjust the thermostat slowly, then firmly grasp and twist hot water tap handle while pressing down activator button for 20 seconds to bring in fresh water to be heated at the new setting. Allow 5-7 minutes for water to reach new temperature.
Water comes out of the vent instead of spout.	<ul style="list-style-type: none"> • Outlet tube is blocked. 	<ul style="list-style-type: none"> • Check that outlet tube is not kinked, twisted or pinched. • Unscrew spout end piece and clean out any debris.
Water is dripping from the spout/vent intermittently.	<ul style="list-style-type: none"> • The expansion chamber is not draining properly due to low water pressure. • The spout is blocked. 	<ul style="list-style-type: none"> • Unplug the unit.If the dripping does not stop after a few minutes, check the supply valve to ensure that is fully open and there are no obstructions in the water line reducing the pressure below 207kPa (30 psi) (ie, a poorly mounted saddle valve, a clogged water filter or a partially opened shut-off valve). • Unscrew spout end piece and clean out any debris.
Water is dripping from the spout/vent constantly.	<ul style="list-style-type: none"> • Debris in the water line may be in the tap valve seat, causing a slow water leak. 	<ul style="list-style-type: none"> • Unscrew spout end piece and clean out any debris. • Firmly grasp and twist hot water tap handle while pressing down activator button 7-10 times to flush tap and lines.
Divided stream.	<ul style="list-style-type: none"> • Debris in the end piece. 	<ul style="list-style-type: none"> • Unscrew spout end piece and clean out any debris.
Water discolouration/ rusty appearance.	<ul style="list-style-type: none"> • Corrosion of unit. 	<ul style="list-style-type: none"> • Unplug and drain unit. If the water discolouration remains after draining and refilling the unit, discontinue use and contact an authorised InSinkErator service agent.

CARE AND USE



CAUTION: Electric Shock Hazard. To prevent electrical shock, disconnect power before servicing unit. Use only a properly earthed and polarised electric outlet.

NOTICE

- Regularly inspect the unit for any signs of leakage. If there are signs of water damage, immediately remove the unit from service.
- A drainage pan, plumbed to an appropriate drain or outfitted with a leak detector, should be used in those applications where any leakage could cause property damage.

CLEANING THE TAP

- Use only mild cleaners to clean the tap and plastic components.
- Cleaners with acids, abrasives, alkaline or organic solvents will result in deterioration of the plastic components and void the warranty.

PERSONAL INJURY

- Regularly check for signs of corrosion by examining the appearance of the dispensed water.
- If the water discolouration remains after draining and refilling the unit, discontinue use and contact an authorised InSinkErator service agent.