

# EVOLUTION<sup>®</sup> 100 TECHNOLOGY

Featuring two-stage grinding combined with SoundSeal™ Plus technology, the Evolution 100 is more powerful and quieter than our standard range. It virtually grinds any food waste, including difficult items such as bones and potato peel.

## FEATURES



SoundSeal Plus™  
Evolution Quieter  
Technology



0.75HP Dura-Drive™  
Heavy Duty  
Induction Motor



MultiGrind Plus™  
2 Stage Stainless  
Grinding System with  
Auto Reverse Action



QuickLock™  
Sink Mount for  
easy installation



Large Capacity  
(1005ml) Stainless  
Steel Grinding Chamber



5 Year Warranty



Built-in Air Switch  
(33mm hole for button)



Made in the USA



## DIMENSIONS (MM)

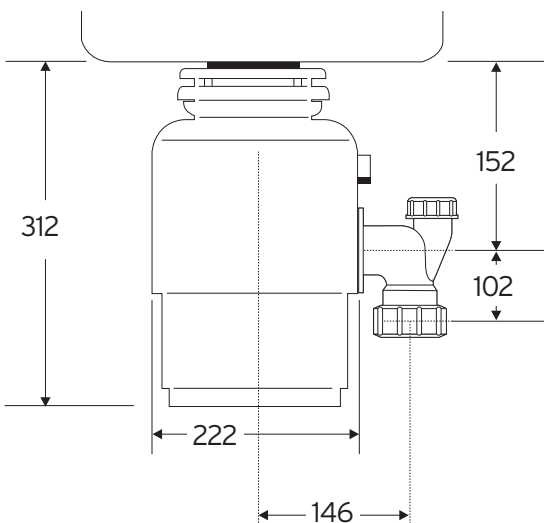

## SPECIFICATIONS

Type of Feed	Continuous	Sound Technology	Anti-Vibration Mounting Technology and Tailpipe
On/Off	Control Wall Switch or Built-In Air Switch	Plug	Quiet Sink Baffle Multi-Layer Sound Insulation Stainless Steel Strainer Basket and Plug
Power Supply	Single Phase	Grind Chamber Capacity	1005 ml
Reversing	Auto-Reverse Grind System	Motor Protection	Manual Reset Overload
Time Rating	Intermittent	Average Water Usage	Approximately 4.0 L per Person per Day
Lubrication	Permanently Lubricated Upper & Lower Bearings	Average Electrical Usage	3-4 KWH per Annum
Shipping Weight	8.8 kg (Approx.)	Drain Connection	1-1/2" (3.81 cm) Anti-Vibration (Hose Clamp)
Unit Finish	Black Enamel Grey TEN-1706	Dishwasher Connection	Yes
Overall Height	312 mm		
Grind Technology	2-Stage Grind Technology		
Volts/Hz	HP	RPM	
220-240V, 50 Hz	.75	1425	

**insinkerator.co.nz**

For more information contact Parex Industries Limited on Tel: 0800 200 510 or email: info.parex@emerson.com

InSinkErator reserves the right to change product specifications without prior notice. The disposer described in this leaflet is for household use; usage in commercial situations is not covered by warranty.

**in sink erator<sup>®</sup>**