



MODEL 66

FOOD WASTE DISPOSER

The top model in our standard range, offering high performance, continuous feed operation and able to handle a wide variety of food waste.

FEATURES



SoundSeal Plus™
Quieter than
standard models



0.75HP Dura-Drive™
Heavy Duty
Induction Motor



1 Stage Stainless
Grinding System



QuickLock™
Sink Mount for
easy installation

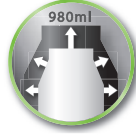

Grind Chamber
Capacity (980ml)
Stainless Steel
Grinding Elements



4 Year Warranty



Built-in Air Switch
(33mm hole for button)



Made in the USA

DIMENSIONS (MM)

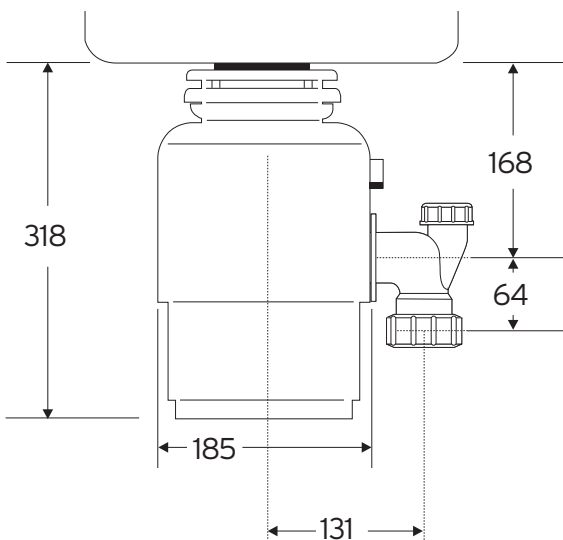

SPECIFICATIONS

Type of Feed On/Off	Continuous Control Wall Switch or Built-In Air Switch	Grind Chamber Capacity	980 ml
Power Supply	Single Phase	Motor Protection	Manual Reset Overload
Time Rating	Intermittent	Average Water Usage	Approximately 4.0 L per Person per Day
Lubrication	Permanently Lubricated Upper & Lower Bearings	Average Electrical Usage	5-6 KWH per Annum
Grind Technology	1-Stage Grind Technology	Drain Connection	1-1/2" (3.81 cm)
Sound Technology	Quiet Sink Baffle Sound Insulation	Dishwasher Connection	Yes
Volts/Hz	HP	RPM	
220-240V, 50 Hz	.75	1490	

insinkerator.co.nz

For more information contact Parex Industries Limited
on Tel: 0800 200 510 or email: info.parex@emerson.com

InSinkErator reserves the right to change product specifications without prior notice.
The disposer described in this leaflet is for household use; usage in commercial situations is not covered by warranty.

