



MODEL 46

FOOD WASTE DISPOSER

The entry level InSinkEerator model, suitable for lighter use in smaller households.

FEATURES



Basic Sound Reduction Technology



Air Switch Kit Available (33mm hole for button)



1 Stage Grinding System



0.55HP Dura-Drive™ Heavy Duty Induction Motor



Grind Chamber Capacity (980ml)



2 Year Warranty



QuickLock™ Sink Mount for easy installation



Made in the USA

DIMENSIONS (MM)

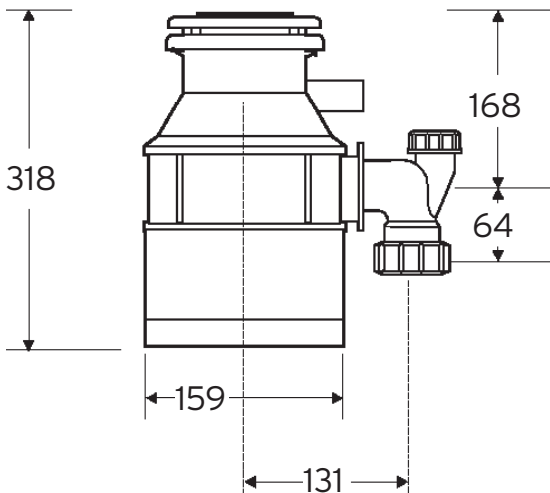

SPECIFICATIONS

Type of Feed	Continuous	Grind Chamber Capacity	980 ml
On/Off	Wall Switch	Motor Protection	Manual Reset Overload
Power Supply	Single Phase	Average Water Usage	Approximately 4.0 L per Person per Day
Time Rating	Intermittent	Average Electrical Usage	5-6 KWH per Annum
Lubrication	Permanently Lubricated Upper & Lower Bearings	Drain Connection	1-1/2" (3.81 cm)
Grind Technology	1-Stage Grind Technology	Dishwasher Connection	Yes
Sound Technology	Quiet Sink Baffle Sound Insulation		

Volts/Hz	HP	RPM
220-240V, 50 Hz	.55	1490

insinkerator.co.nz

For more information contact Parex Industries Limited on Tel: 0800 200 510 or email: info.parex@emerson.com

InSinkEerator reserves the right to change product specifications without prior notice. The disposer described in this leaflet is for household use; usage in commercial situations is not covered by warranty.

