

Amphibian Wall

Amphibian Guide Wall
part no. 17845

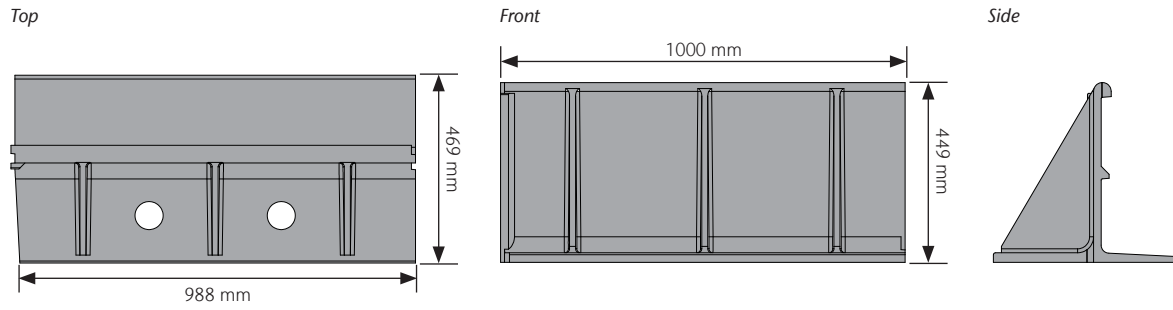

Amphibian Guide Wall - Inner Curve
part no. 18407

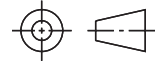
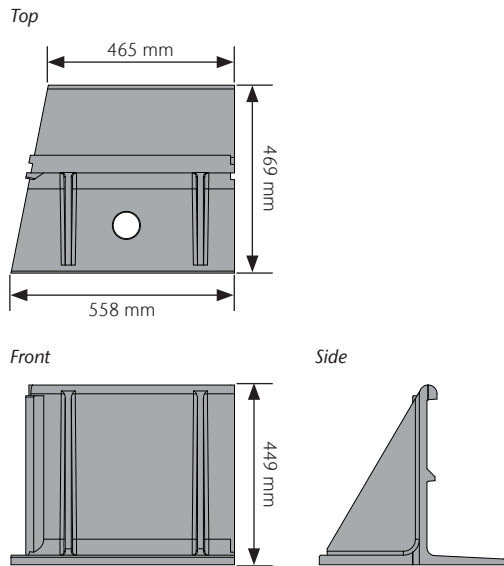

Amphibian Guide Wall - Outer Curve
part no. 18408

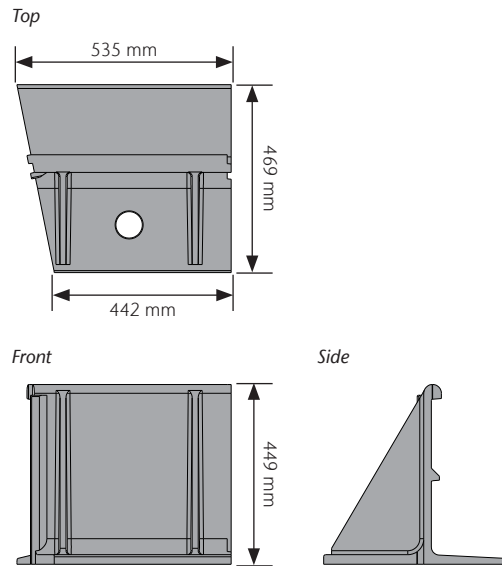

Amphibian Guide Wall - Ascending Element
part no. 18406

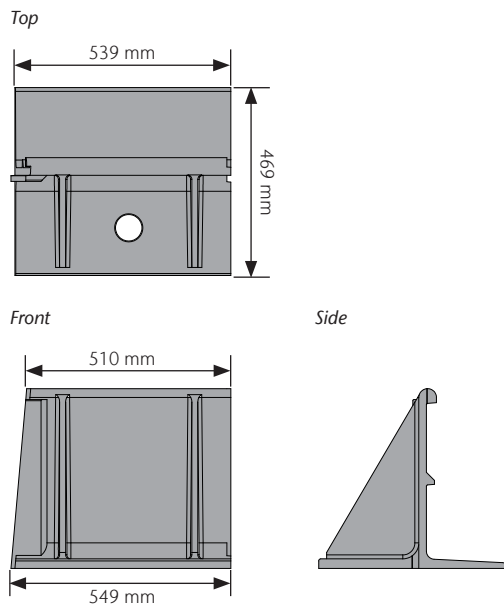

Amphibian Guide Wall - Cascading Element
part no. 18405

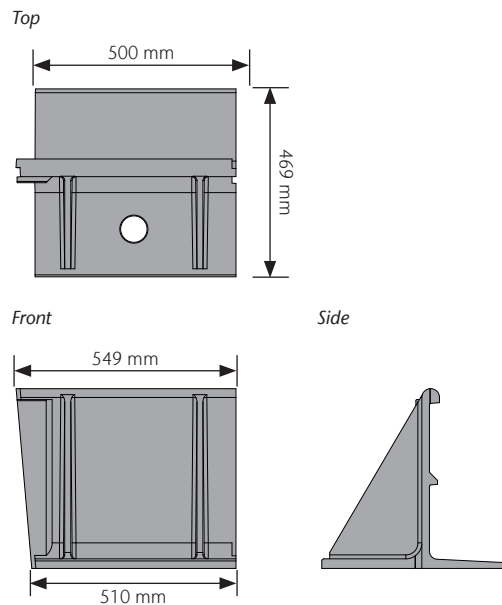

ACO Specification Information

Amphibian Wall

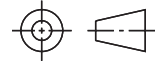

Parts	Part No.	Length in (mm)	Width in (mm)	Weight kg
Amphibian Guide Wall	17845	1000	469	45.99
Amphibian Guide Wall - Inner Curve	18407	558	469	25.04
Amphibian Guide Wall - Outer Curve	18408	535	469	25.04
Amphibian Guide Wall - Ascending Element	18406	539	469	24.04
Amphibian Guide Wall - Cascading Element	18405	549	469	27.03

Product Features

- Protrusions along the front face prevent small animals from climbing over the wall.
- Non-absorbent surfaces with minimal thermal conductivity.
- High-strength polymer concrete build with no metal reinforcements.

Specifications

General

The Amphibian Wall system shall be ACO Wildlife KT500 Tunnel, Fence and Entrance as manufactured by ACO, Inc.

Materials

Fence, Post, AT500 Tunnel Entrance and Swallow Tail shall be manufactured from recycled plastic with the minimum properties as follows:

- Compressive strength: 13,053 psi
- Flexural strength: 3,191 psi
- Water absorption: 0.07%
- Resistant to dilute acid and alkali
- Frost-proof
- Salt-proof

Tunnel

See separate ACO Wildlife KT500 Tunnel Spec Info sheet for details.

Installation

The tunnel and fencing system shall be installed in accordance with the manufacturer's installation instructions and recommendations.

ACO Specification Information

**ACO Limited
New Zealand**

Unit F/6 Percival Gull Place
Mangere, Auckland 2022
New Zealand
Tel: +64 (0)9 815 9500
Toll-Free: 0800 448 080

info@aconz.co.nz
www.aconz.co.nz

© October 2021 ACO Limited. All reasonable care has been taken in compiling the information in this document. All recommendations and suggestions on the use of ACO products are made without guarantee since the conditions of use are beyond the control of the company. It is the customer's responsibility to ensure that each product is fit for its intended purpose and that the actual conditions are suitable. ACO Limited pursues a policy of continuous product development and reserves the right to amend specifications without notice.

ACO. creating
the future of drainage

