

SEMI FRAMELESS ALUMINIUM POSTS

Typical Base Fix Embedment into Concrete

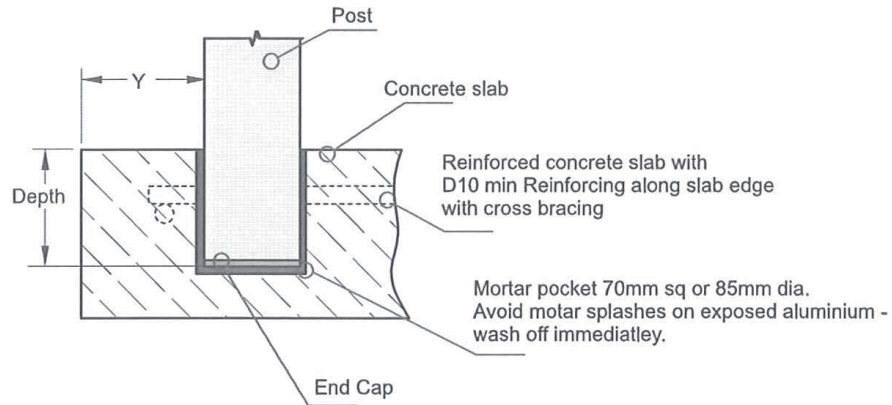

Concrete Type	Y (min)	Depth (min)
Reinforced Slab	70mm	95mm

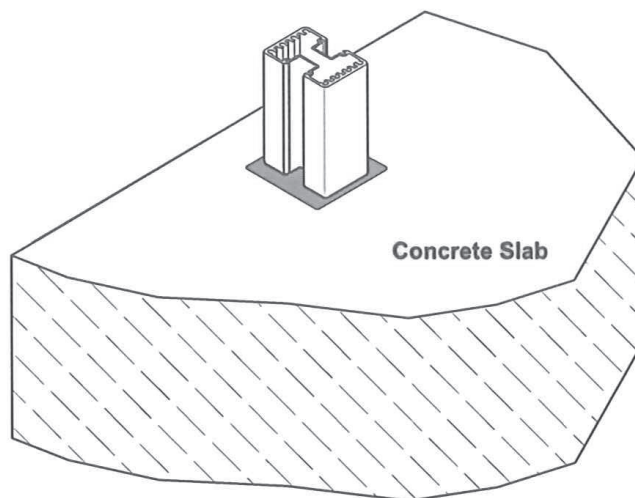

Design engineer must ensure deck can support a moment of 1.7 KNm applied at each post

Ex Auckland Store. All prices exclude G.S.T.