

EUROSTYLE ROLL CAP WALL CLADDING

WALL CLADDING BASE OF VERTICAL CLADDING ON CAVITY

Detail Number: RI-ERCW005A

Date drawn: 02/02/2018

Scale: 1 : 5@ A4

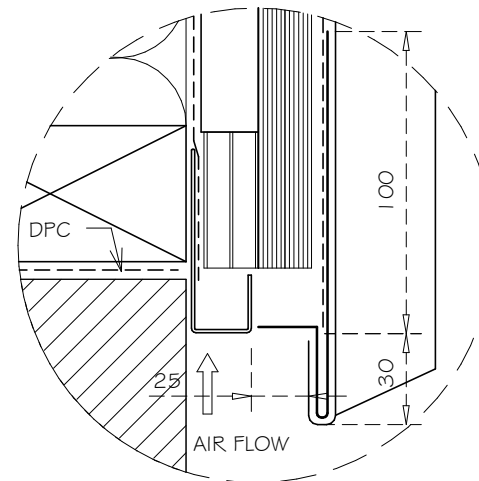
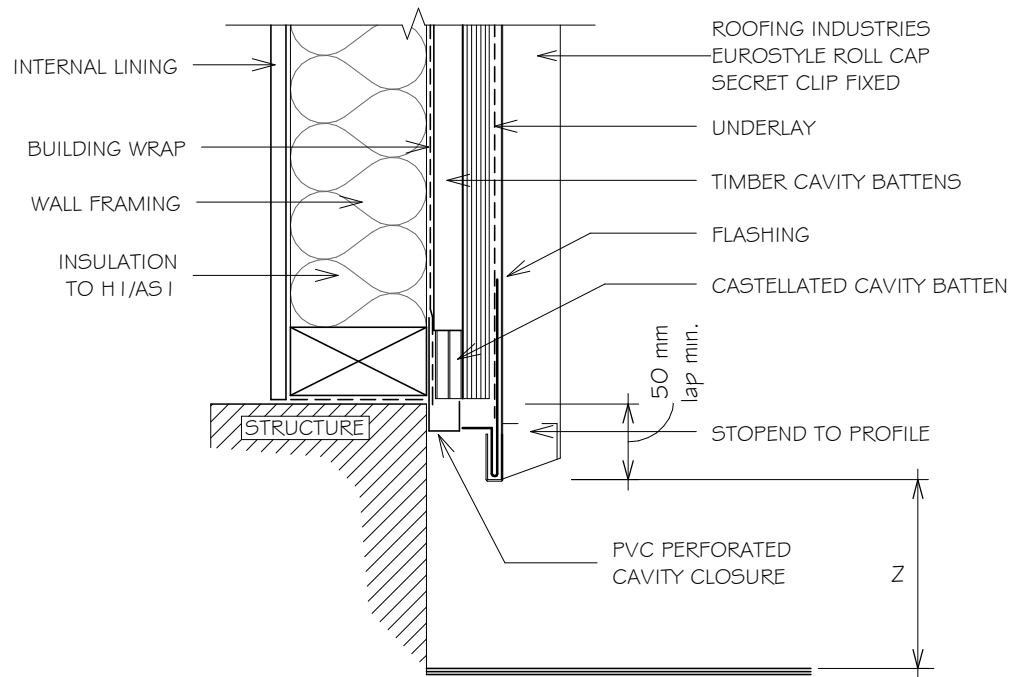

1. FOR FIXING METHODS REFER TO SPECIFICATIONS.
2. THIS DETAIL TO BE CONFIRMED BY ROOFING INDUSTRIES TECHNICAL DEPT PRIOR TO USE.
3. ALLOW FOR SEPARATION FROM ANY CORROSIVE TIMBER TREATMENTS.
4. ALL DIMENSIONS SHOWN ON DRAWINGS ARE NOMINAL +/- 5mm
5. CASTELLATED TIMBER BATTEN OR APPROVED DRAINED BATTEN MAY BE USED WITH THIS SYSTEM.

SET DOWN	MINIMUM
	Z
PAVED SURFACE	100mm
UNPAVED SURFACE	175mm

NOTES:

- These details are generally in compliance the NZ Metal Roof & Wall Cladding Code of Practice and in some cases specific details by 'Roofing Industries'. Eurostyle falls outside the criteria of E2/AS1 and this document is therefore not applicable.
- The building designer is ultimately responsible to ensure that details used meet the requirements of the NZ Building Code for the specific project.
- Details of the supporting structure including cavity battens are indicative only and are the responsibility of the building designer. For steel framed buildings thermal break cavity battens may be required.
- Underlay selection and building wrap types are the responsibility of the designer.
- These details are for Roofing Industries profile/s as nominated and may not be applicable to other profiles.
- This drawing is the copyright of 'Roofing Industries' and can only be copied or reproduced with their permission.
- These details to be read with Roofing Industries profile technical summary regarding wind loads and fixings.
- Further information can be obtained from the NZ Metal Roof & Wall Cladding Code of Practice: www.metalroofing.org.nz or E2/AS1.

Copyright detail © 2017

