

EUROSTYLE ROLL CAP ROOFING

TYPICAL VALLEY DETAIL

Detail Number: RI-ERCRO06B-1

Date drawn: 02/02/2018

Scale: 1 : 5 @ A4

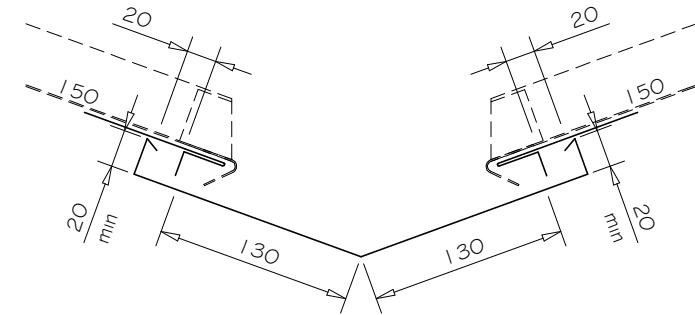
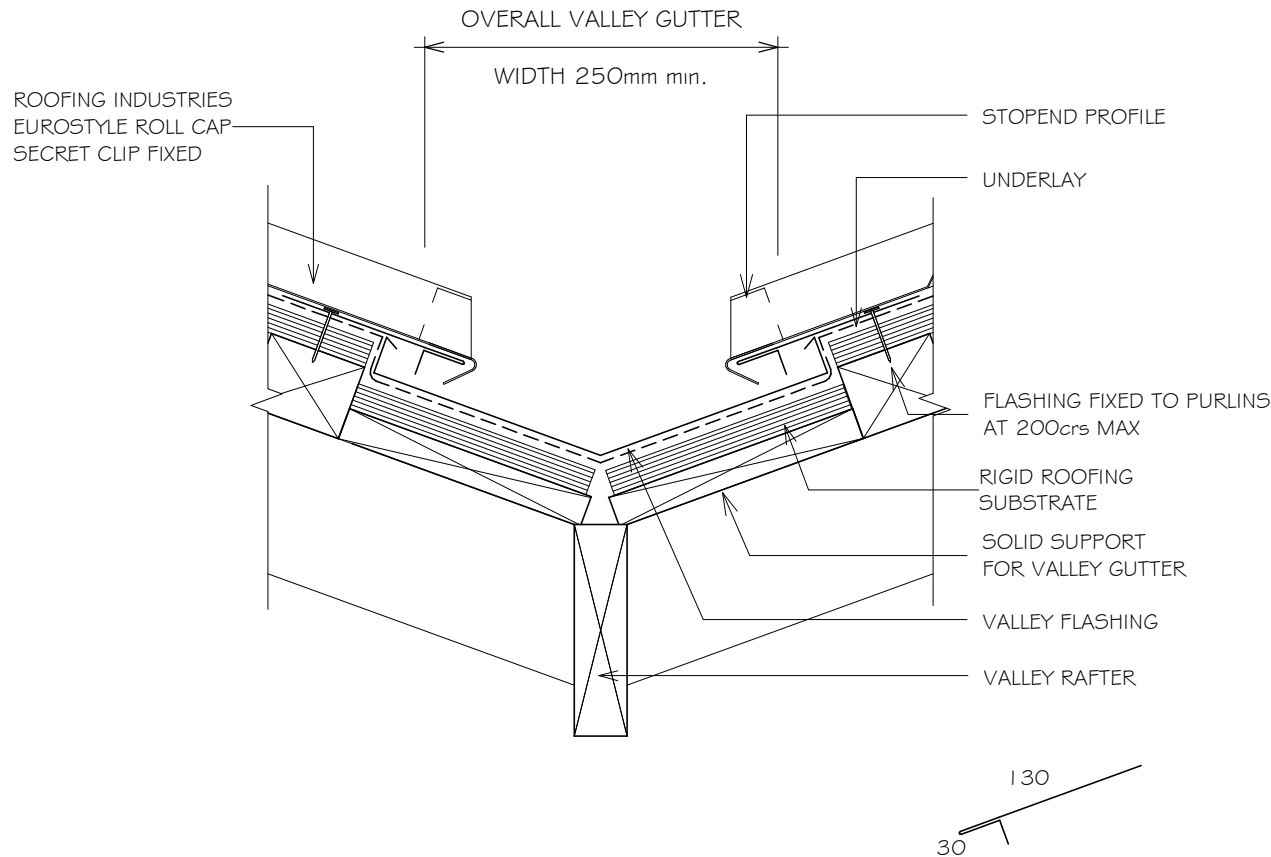

(Dimensions are indicative only)

NOTES:

1. ALLOW FOR SEPARATION FROM ANY CORROSIVE TIMBER TREATMENTS.
2. HIGH TO EXTRA HIGH WIND ZONE DOUBLE FIX UNDERFLASHINGS.
3. ALL DIMENSIONS SHOWN ON DRAWINGS ARE NOMINAL +/- 5mm

NOTES:

- These details are generally in compliance the NZ Metal Roof & Wall Cladding Code of Practice and in some cases specific details by 'Roofing Industries'. Eurostyle falls outside the criteria of E2/AS1 and this document is therefore not applicable.
- The building designer is ultimately responsible to ensure that details used meet the requirements of the NZ Building Code for the specific project.
- Details of the supporting structure including cavity battens are indicative only and are the responsibility of the building designer. For steel framed buildings thermal break cavity battens may be required.
- Underlay selection and building wrap types are the responsibility of the designer, Netting or other support is generally required at roof pitches less than 10 degrees combined with a self supporting paper. At roof pitches of 10° and above where non self supporting paper is used or purlin spacing is in excess of self supporting criteria, netting or other support should be used. Alternative support to netting should be used in severe coastal environments including when aluminium is used. (Refer to NZS 2295)
- These details are for Roofing Industries profile/s as nominated and may not be applicable to other profiles.
- This drawing is the copyright of 'Roofing Industries' and can only be copied or reproduced with their permission.
- These details to be read with Roofing Industries profile technical summary regarding wind loads and fixings.
- Further information can be obtained from the NZ Metal Roof & Wall Cladding Code of Practice: www.metalroofing.org.nz or E2/AS1.

HEM TO BE CLEAR OF PAN 3-5mm

Copyright detail © 2017

