

RESIDENTIAL SLIMCLAD WALL CLADDING

JAMB FLASHING FOR HORIZONTAL CLADDING (RECESSED WINDOW/DOOR)

Detail Number: RI-RSCW032B

Date drawn: 06/09/2021

Scale: 1 : 5 @ A4

DETAIL ANNOTATION:

1. REFER TO E2/AS 1 FOR GENERAL WINDOW OPENING FOR WRAPPING OF FRAMED OPENING PRIOR TO WINDOW INSTALLATION.
2. WINDOW PROFILE TO BE SELECTED TO ACHIEVE COVER SHOWN IN DETAILS.
3. ARCHITRAVE'S ARE SHOWN FOR CONSISTENCY ONLY, DETAIL MAY BE USED WITH REBATED LINER.
4. WHERE SUPPORT BRACKETS ARE REQUIRED BY THE WINDOW MANUFACTURER TO CARRY THE FRAME AND GLAZING LOADS THEY MUST BE SUPPLIED AS AN INTEGRAL PART OF THE WINDOW MANUFACTURER'S RECOMMENDATIONS.
5. LIAISE WITH WINDOW MANUFACTURER PRIOR TO INSTALLATION.
6. FASTENERS TO BE COMPATIBLE WITH MATERIAL BEING FIXED AND THE SUITABLE GRADE FOR THE ENVIRONMENT IN WHICH LOCATED
7. ALTERNATIVELY REFER TO E2/AS 1 FOR FLASHING COVER GUIDANCE

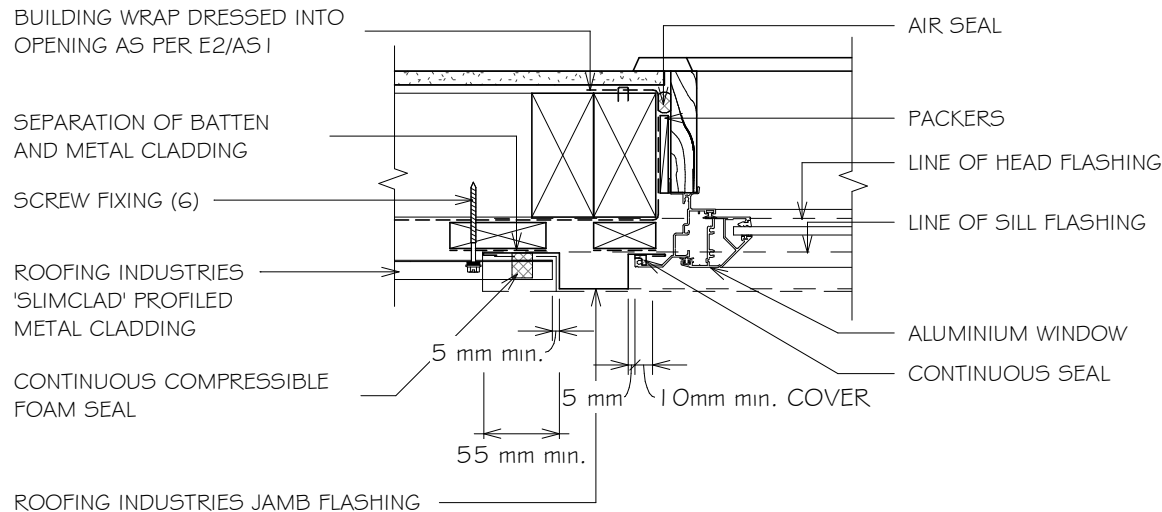

SLIMCLAD IS OUTSIDE THE SCOPE OF E2/AS 1 BUT MAYBE APPLICABLE FOR NON RESIDENTIAL BUILDINGS OR AS AN ALTERNATIVE SOLUTION

SOAKER FLASHING MAY BE REQUIRED IN WIND ZONE GREATER THAN VERY HIGH. BACK TRAY TO RUN FROM TOP OF HEAD FLASHING TO GROUND OR EXIT POINT.

REFERENCE FLASHINGS:
NZ METAL ROOF AND WALL CLADDING CODE OF PRACTICE SEPTEMBER 2008.
SEE CODE OF PRACTICE 6.4.2A..

GENERAL NOTES:

- These details are to be read with Roofing Industries profile technical summary regarding wind loads and fixings.
- These details are generally in compliance with E2/AS 1 and/or the NZ Metal Roof & Wall Cladding Code of Practice and in some cases specific details by 'Roofing Industries'.
- The building designer is ultimately responsible to ensure that details used meet the requirements of the NZ Building Code for the specific project.
- Details of the supporting structure including cavity battens are indicative only and are the responsibility of the building designer. For steel framed buildings thermal break cavity battens may be required.
- Roof/wall underlay selection are the responsibility of the designer. Underlay to be installed in accordance with underlay manufacturer's recommendations and requirements.
- These details are for Roofing Industries profile/s as nominated and may not be applicable to other profiles.
- This drawing is the copyright of 'Roofing Industries' and can only be copied or reproduced with their permission.
- Further information can be obtained from the NZ Metal Roof & Wall Cladding Code of Practice: www.metalroofing.org.nz or E2/AS 1.
- Details are for steel based materials, other substrates may require some changes.
- All dimensions are nominal.

Copyright detail © 2021

