

RESIDENTIAL SLIMCLAD WALL CLADDING

VERTICAL BUTT JOINT - VERTICAL CLADDING ON CAVITY WITH CLADDING CHANGE (CAVITY)

Detail Number: RI-RSCW009B-1

Date drawn: 06/09/2021

Scale: 1 : 5 @ A4

VERTICAL FLASHING TO COVER MINIMUM OF 2 CRESTS OR 1 CREST AND A FULL HEIGHT TURN-UP AND FINISH 2-5mm GAP FROM PAN OF CLADDING

ROOFING INDUSTRIES 'SLIMCLAD' PROFILED METAL CLADDING

FLASHING RIVET FIXED TO CLADDING

HORIZONTAL DRAINED BATTEN (2)

BUILDING WRAP

VERTICAL NOG

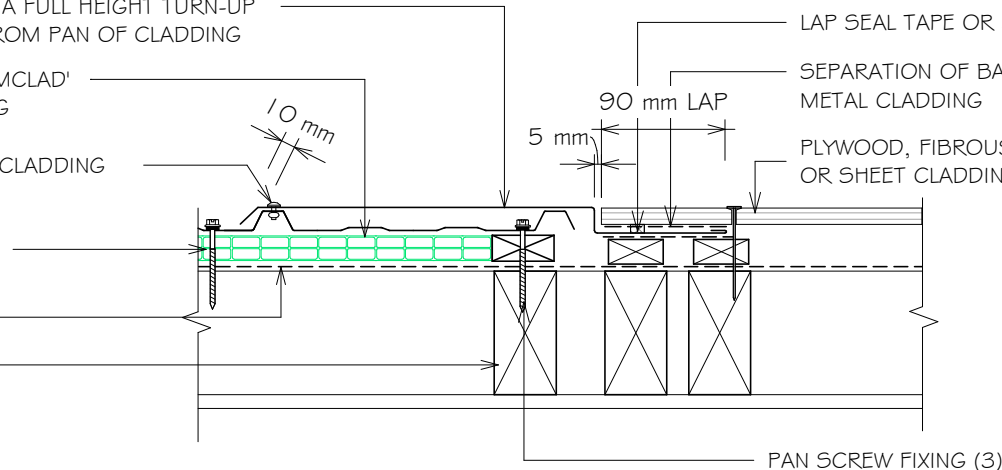

LAP SEAL TAPE OR SEALANT

SEPARATION OF BATTEN/PLYWOOD AND METAL CLADDING

PLYWOOD, FIBROUS CEMENT OR SHEET CLADDING

PAN SCREW FIXING (3)

SLIMCLAD IS OUTSIDE THE SCOPE OF E2/AS 1 BUT MAYBE APPLICABLE FOR NON RESIDENTIAL BUILDINGS OR AS AN ALTERNATIVE SOLUTION

DETAIL ANNOTATION:

1. CAVITY BATTENS CONTAINING CORROSIVE MATERIAL MUST BE SEPARATED FROM METAL CLADDING BY DPC, BUILDING WRAP, PVC OR PAINTING
2. CASTELLATED BATTEN, DRAINAGE PLASTIC BATTEN OR APPROVED DRAINED BATTEN CAN BE USED WITH THIS SYSTEM
3. FASTENERS TO BE COMPATIBLE WITH MATERIAL BEING FIXED AND THE SUITABLE GRADE FOR THE ENVIRONMENT IN WHICH LOCATED

GENERAL NOTES:

- These details are to be read with Roofing Industries profile technical summary regarding wind loads and fixings.
- These details are generally in compliance with E2/AS 1 and/or the NZ Metal Roof & Wall Cladding Code of Practice and in some cases specific details by 'Roofing Industries'.
- The building designer is ultimately responsible to ensure that details used meet the requirements of the NZ Building Code for the specific project.
- Details of the supporting structure including cavity battens are indicative only and are the responsibility of the building designer. For steel framed buildings thermal break cavity battens may be required.
- Roof/wall underlay selection are the responsibility of the designer. Underlay to be installed in accordance with underlay manufacturer's recommendations and requirements.
- These details are for Roofing Industries profile/s as nominated and may not be applicable to other profiles.
- This drawing is the copyright of 'Roofing Industries' and can only be copied or reproduced with their permission.
- Further information can be obtained from the NZ Metal Roof & Wall Cladding Code of Practice: www.metalroofing.org.nz or E2/AS 1.
- Details are for steel based materials, other substrates may require some changes.
- All dimensions are nominal.

Copyright detail © 2021

