

# RESIDENTIAL SLIMCLAD WALL CLADDING HEAD BARGE FOR VERTICAL CLADDING ON CAVITY ON CAVITY (KICK OUT)

Detail Number: RI-RSCW002A-1

Date drawn: 06/09/2021

Scale: 1 : 5 @ A4

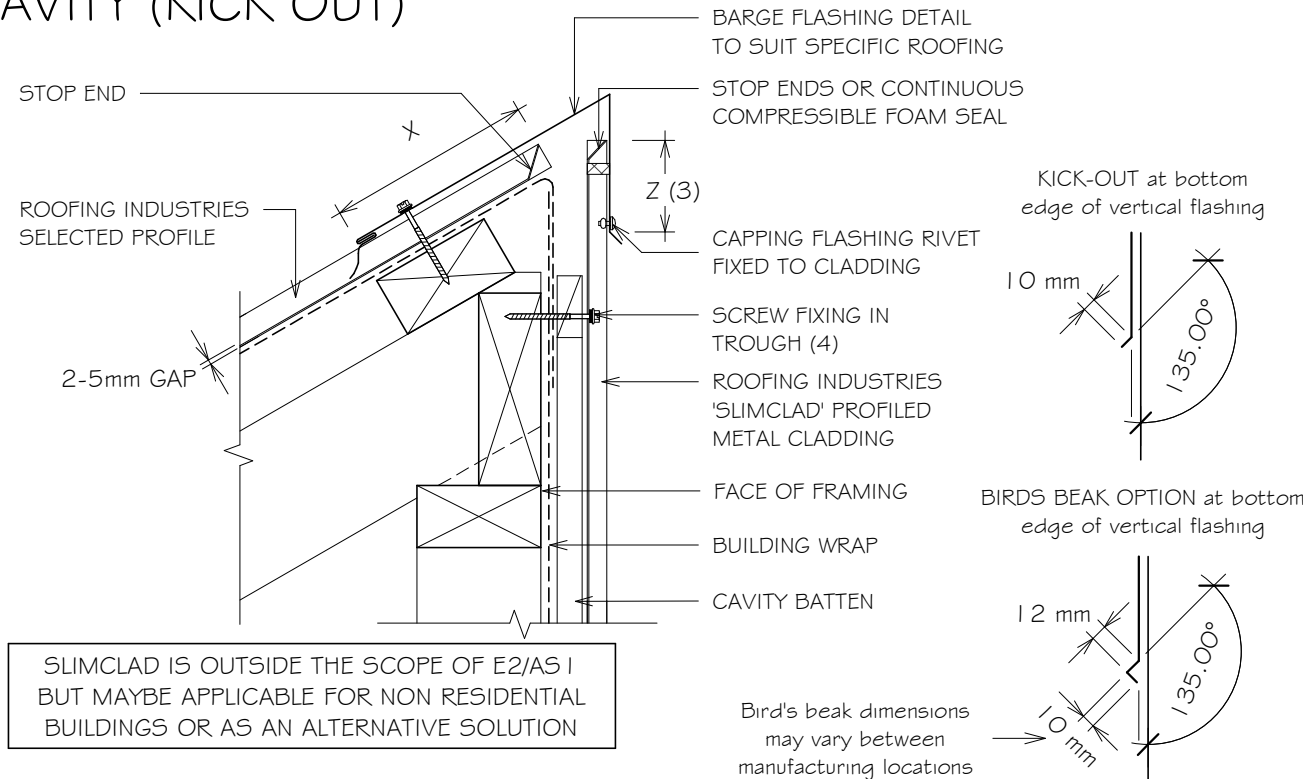

SLIMCLAD IS OUTSIDE THE SCOPE OF E2/AS 1 BUT MAYBE APPLICABLE FOR NON RESIDENTIAL BUILDINGS OR AS AN ALTERNATIVE SOLUTION

SITE WIND ZONE (As per NZS3604) (1)	MINIMUM	
	Z (2)	X
SITUATION 1 (6)	75mm	130mm
SITUATION 2 & 3 (6)	100mm	200mm

DETAIL ANNOTATION:

1. SITUATION 1, 2 & 3 AS PER E2/AS 1 TABLE 7
2. EXCLUDING DRIP EDGE.
3. INCREASE DISTANCE 'Z' BY 25mm WHEN AGAINST A PROFILED SURFACE OR TO 100mm WHICHEVER IS LESSER
4. FASTENERS TO BE COMPATIBLE WITH MATERIAL BEING FIXED AND THE SUITABLE GRADE FOR THE ENVIRONMENT IN WHICH LOCATED
5. CAVITY BATTENS OR PACKERS CONTAINING CORROSIVE MATERIAL MUST BE SEPARATED FROM METAL CLADDING BY DFC, BUILDING WRAP, PVC OR PAINTING
6. ALTERNATIVELY REFER TO E2/AS 1 FOR FLASHING COVER GUIDANCE.

GENERAL NOTES:

- These details are to be read with Roofing Industries profile technical summary regarding wind loads and fixings.
- These details are generally in compliance with E2/AS 1 and/or the NZ Metal Roof & Wall Cladding Code of Practice and in some cases specific details by 'Roofing Industries'.
- The building designer is ultimately responsible to ensure that details used meet the requirements of the NZ Building Code for the specific project.
- Details of the supporting structure including cavity battens are indicative only and are the responsibility of the building designer. For steel framed buildings thermal break cavity battens may be required.
- Roof/wall underlay selection are the responsibility of the designer. Underlay to be installed in accordance with underlay manufacturer's recommendations and requirements.
- These details are for Roofing Industries profile/s as nominated and may not be applicable to other profiles.
- This drawing is the copyright of 'Roofing Industries' and can only be copied or reproduced with their permission.
- Further information can be obtained from the NZ Metal Roof & Wall Cladding Code of Practice: [www.metalroofing.org.nz](http://www.metalroofing.org.nz) or E2/AS 1.
- Details are for steel based materials, other substrates may require some changes.
- All dimensions are nominal.

Copyright detail © 2021

