

ZDF-6152XL DUAL FLUSH VALVE

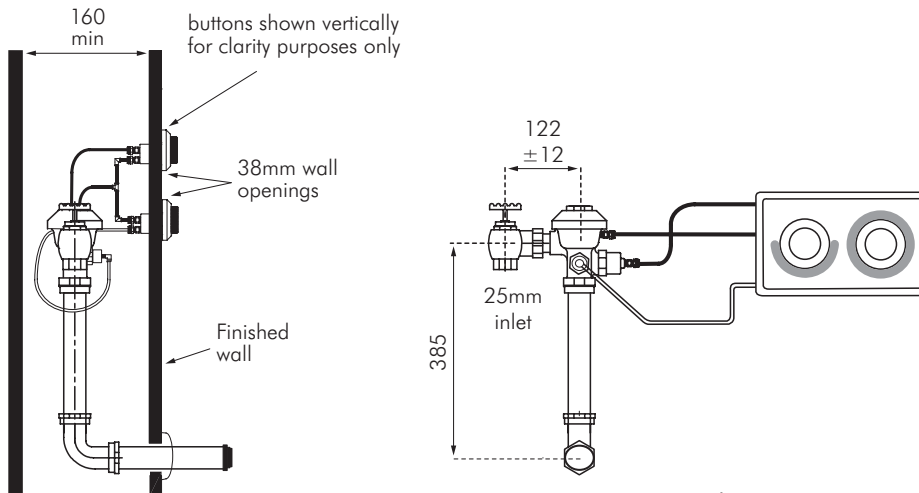

FOR USE WITH W.C. PANS

Dual Flush 6/3L
 Remote push buttons
 Mains Pressure Supply
 Recess mounted



DESCRIPTION

Zurn Model ZDF-6152XL flush valve is a hydraulically actuated WC flushing valve suitable for installation using mains pressure water supply. The standard valve is pre-set to deliver a 6/3L flush and has achieved the distinction of Australian Standards Watermark approval and WELS 3 Star rating.

All pipework must be designed by a suitably qualified person to enable the valve to operate correctly under the pressure and flow rates required.

Valve is suitable for recess mounting in suitably sized duct space (see drawing above). The valve is sold as 2 separate components, this inwall valve (which is common to all dual flush valves) and the push button assembly.

Both items must be specified separately. Refer to separate sheet for options on push button assemblies.

In order to comply with approvals is not possible to remote mount this valve and extend any pipework.

SPECIFICATION

Suitable for connection to 6 litre back entry pans.

Minimum Pressure: 150kPa dynamic

Maximum Pressure: 500kPa

Flow Rate: 90L/min

Inlet Connection: 25 BSP

Flush Volume: 6/3L adjustable

MODEL

ZDF-6152XL - c/w 25mm isolator.

Note: These are the inwall valves only, NOT the push plate/ buttons - REFER SEPARATE INFORMATION.

