

BE-BT20

MACDONALD FOLD DOWN SUPPORT 850mm

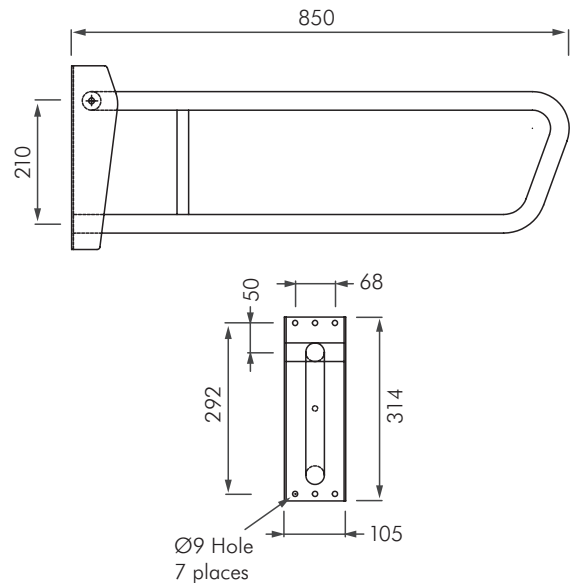
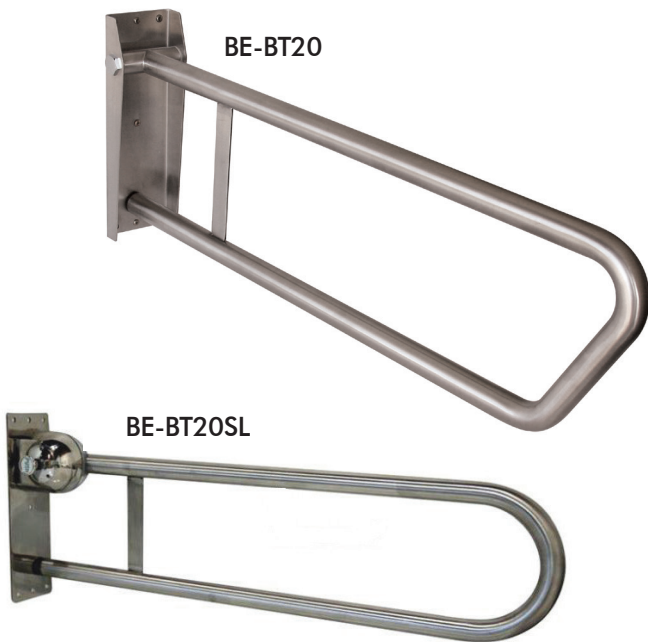

DESCRIPTION

The Macdonald BE-BT20 is a wall mounted fold down support in grade 304 stainless steel, $\text{\O}32\text{mm}$ tubing, with Knurled slip resistant finish. The BE-BT20 is suited for use in the toilet applications for accessible, aged care and home assist bathrooms. It's easy to install on most building surfaces and has been designed for maximum strength. Length of fold down support is 850mm and the wall plate size measures 100x314x5mm.

The fold down support is also available with safelock allowing the rail to lock in the up and down position with push/pull function.

PRODUCT ADVANTAGES

- Quick and easy installation.
- Low maintenance.
- Heavy duty large wall plate for extra stability and strength; dimensions: 100x314x5mm.
- Locking mechanism available as option.
- Dimensions: 850x210mm, $\text{\O}32\text{mm}$.

MODEL

BE-BT20 - 850mm fold down support.

BE-BT20SL - 850mm fold down support with safelock.