



## Energy

### ThermoTech™

# Maximum energy savings, superior interior comfort

Glass plays an increasingly important role as building regulations place great emphasis on saving energy in both residential and commercial designs. The selection of increased thermal insulation, or glass with a lower U Value, combined with solar control, is an important decision in a building envelope's thermal performance.

Viridian ThermoTech™ is a range of sealed insulating glass units that offer improved insulation. For example: by incorporating Viridian EnergyTech™ a Low-Emissivity (Low E) glass for greater thermal insulation, ThermoTech decreases heat conduction between outside and inside; or by selecting solar control glass with reflective or Low-Emissivity coatings (eg Viridian EVantage™), ThermoTech can optimise energy management whilst maintaining natural light transmission.

By reducing the air-to-air heat transfer, ThermoTech provides a more stable and controllable internal environment and is suitable for all climates.

There are three spacer options within the ThermoTech range.

#### Metal Spacer

Two pieces of glass are separated by a metal spacer and sealed to provide a hermetically sealed air gap. It has a primary water vapour proof seal and the secondary seal is supplied standard as polysulphide. Structural silicone secondary seal is an option upon request. The airspace is provided with a desiccant to prevent condensation forming within the unit.

#### Features and benefits

- ◆ Increased insulation and reduced energy costs
- ◆ Wide range of solar control options that can be customised for each project
- ◆ Suitable for hot and cold climates
- ◆ Can be incorporated with a Low E coating for additional insulation
- ◆ Reduced condensation

#### Thermoplastic Spacer TPS®

TPS® is a butyl-based thermoplastic material. It is UV stable with integrated desiccant and applied directly onto the glass by a computer-controlled nozzle. This non-metallic spacer offers the ultimate heat insulation. In itself, it is an effective gas and moisture barrier. Units are supplied with polysulphide secondary seal as standard. The space is filled with argon gas as standard which further enhances the performance of the unit. Combine it with a silicone secondary seal and it is perfectly suited for structural glazing. Structural silicone is available as an option upon request.

#### Features and benefits

- ◆ Almost any shape, size and thickness including offset or stepped units – all four sides are possible
- ◆ Uniform temperature over the entire surface
- ◆ Tolerates thermal stresses and pumping wind loads
- ◆ Structural silicone seal (upon request) with argon gas fill for unmatched insulation
- ◆ Reduces outside noise factors by up to 50% or more
- ◆ Argon gas standard
- ◆ Inbuilt desiccant in the TPS® prevents condensation forming in the unit
- ◆ Triple glazed options are also available

Performance comparison chart			
ThermoTech	Insulation	Solar	Daylight
Clear	2.5	0.71	78
SuperGreen	2.5	0.39	59
Evantage SuperGreen	1.7	0.30	44

For comprehensive performance comparison data refer to page 134.

#### Applications

- ◆ Point fixed IGUs applications – refer to Structural section on page 85 for more information
- ◆ Car showrooms
- ◆ Shopping centres
- ◆ Podiums
- ◆ Ground floor atriums
- ◆ Airports
- ◆ Museums
- ◆ Art galleries
- ◆ Sporting grandstands
- ◆ Other commercial applications
- ◆ Residential windows
- ◆ Multi storey apartments

#### Special applications

- ◆ Please consult with Viridian prior to using ThermoTech in the following applications:
- ◆ Structural or silicone glazing
- ◆ Swimming pools
- ◆ Roof glazing
- ◆ Sound reduction

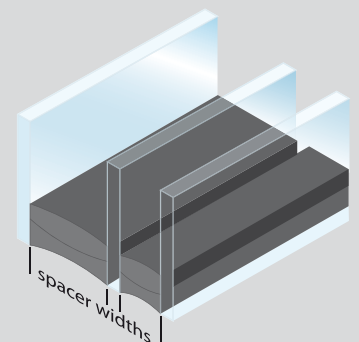

Note: Triple glazing option (shown above) is available in TPS® version only.



# Optimum performance solutions with infinite glass combinations

## Super Spacer

Super Spacer comprises a Thermoset structural foam containing no metal, an integrated 3A desiccant and an advanced multi-layer vapor barrier structure. It is a warm edge solution that minimises the transfer heat escape path for optimal performance.

### Features and benefits

- ◆ Advanced multi-layer vapor barrier structure
- ◆ Integral 3A Desiccant
- ◆ Excellent Resistance to Nitrogen and Argon Gas Absorption
- ◆ Allows for expansion and contraction
- ◆ Structural integrity
- ◆ No compression set
- ◆ Flexible Thermo set structural foam
- ◆ Excellent UV Resistance
- ◆ Temperature Resistance (from -51°C to 127°C)

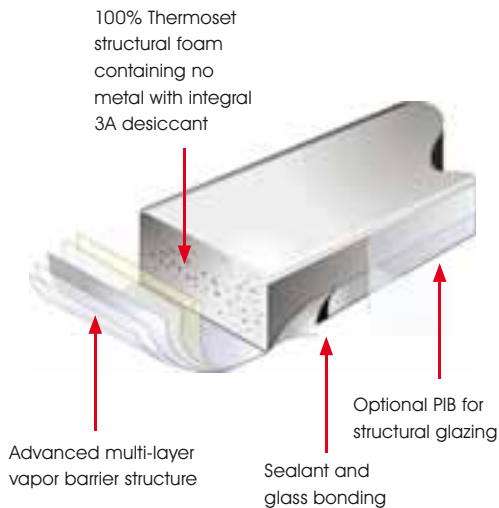

## Considerations

- ◆ Glazing compounds, sealants and gaskets need to be approved by Viridian for suitability.
- ◆ Frame design – the Viridian Warranty relies on frame design in accordance with AS/NZS4666. Do not expose ThermoTech edges to standing water and moisture as this can result in seal failure. The frames must incorporate impervious weather seals or a self draining system.
- ◆ Wind load and safety determine the type and thickness of glass required – refer Australian Standard AS1288 or New Zealand Standard NZS4223.
- ◆ Installation must be in accordance with AS/NZS4666. Please refer to the technical glazing specification on the website for further installation instructions.
- ◆ Visual characteristics and manufacturing tolerances – ThermoTech is manufactured to AS/NZS4666. Also refer to the Viridian website for specification and installation information, including distortion and reflection from changes in exterior and interior pressure and temperature.

## Handling and storage

Special handling is required. Refer to Viridian literature. When transporting above altitudes of 800m, special precautions apply. This must be brought to the attention of Viridian.

## Insulation performance

The width of the spacer and the performance characteristics of the glass selected such as EnergyTech determine the U Value.

Viridian recommends increasing the spacer then adding EnergyTech Low E to economically enhance the insulation performance of the insulating glass unit. Changing the spacer type to TPS® and argon gas will also significantly enhance the total window performance.

Insulation performance – U Value			
	VFloat*	EnergyTech*	EnergyTech* for both panels
Single glass	5.80	3.70	
6mm argon	2.83	2.09	1.97
12mm argon	2.52	1.61	1.48
18mm argon	2.55	1.68	1.54

\*6mm glass – argon filled

Insulation performance – U Value			
	VFloat*	EnergyTech*	EnergyTech* for both panels
Single glass	5.80	3.70	
6mm air	3.10	2.51	2.43
12mm air	2.67	1.87	1.75
18mm air	2.69	1.94	1.83

\*6mm glass air filled

TPS®, Metal Spacer and Super Spacer are available in some markets as standard option – other markets by request.



## Overview of ThermoTech™ spacer range

### ThermoTech™ TPS®

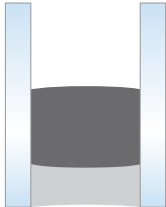

TPS® is a butyl-based thermoplastic material. It is UV stable with integrated desiccant and applied directly onto the glass by a computer-controlled nozzle. This non-metallic spacer offers the ultimate heat insulation with excellent tension, expansion and resilience properties.

#### Maximum size

- ◆ 4500 x 2700mm

#### Minimum size

- ◆ 350 x 190mm

#### TPS® spacer

- ◆ Spacer thickness – any thickness between 6mm to 18mm
- ◆ Unit thickness – 12mm to 58mm
- ◆ Maximum unit thickness is 45mm for double glazed units, 76mm for triple glazed units
- ◆ Maximum glass thickness – 17.52mm
- ◆ Triple glazing – Yes
- ◆ Shapes – Yes
- ◆ Argon gas fill – standard

### ThermoTech™ Metal Spacer

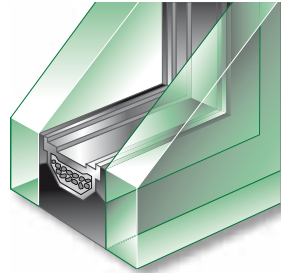

ThermoTech comprises two panels of glass separated by a metal spacer that is sealed with a primary vapour and a secondary seal to provide a hermetically sealed airspace. The spacer has a desiccant to prevent moisture forming inside the ThermoTech unit.

#### Maximum size

- ◆ 3500 x 2000mm

#### Minimum size

- ◆ 350 x 250mm

#### Metal Spacer

- ◆ Argon gas fill – standard
- ◆ Air space – 6, 8, 10, 12, 16, 18 and 20mm
- ◆ Maximum thickness – 47mm
- ◆ Shapes – Subject to factory confirmation

### ThermoTech™ Super Spacer



Super Spacer comprises a Thermoset structural foam containing no metal and integrated 3A desiccant and an advanced multi-layer vapor barrier structure. It is a warm edge solution that minimises the transfer heat escape path for optimal performance.

#### Maximum size

- ◆ 5100 x 2700mm

#### Minimum size

- ◆ 250 x 180mm

#### Super Spacer

- ◆ Argon gas fill – standard
- ◆ Secondary seal – Polysulphide and Silicone
- ◆ Shapes – Yes
- ◆ Unit thickness – 12mm to 52mm double glaze only

#### Reduced condensation

ThermoTech reduces the incidence of condensation. The onset of condensation on the glass depends on the relative indoor humidity, thermal transmittance of the glazing (U Value) and the relative indoor and outdoor temperatures. The lower the U Value, the less likely condensation will occur.

#### Maximum weight

- ◆ If any single IGU exceeds 300kgs please contact Viridian for details

#### Weight

Product (mm)	Weight (kg/m <sup>2</sup> )
4 + 12 Air + 4	20
6 + 12 Air + 6	30
10 + 12 Air + 6	40
12 + 12 Air + 6	45