



**METRO SERIES
BI-FOLD DOOR, OPEN OUT
CROSS SECTIONS**

CAD REF. VMBD02-0

DATE
01.03.17

SCALE
1:2

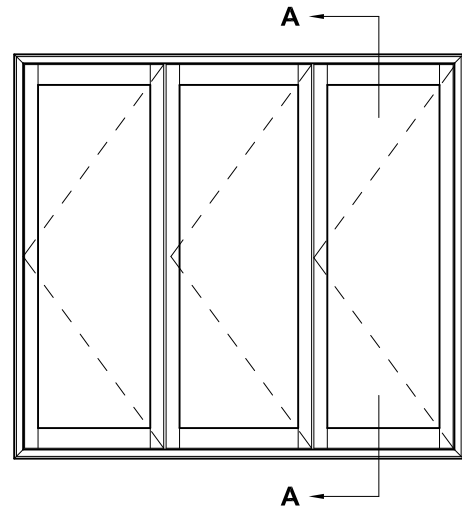
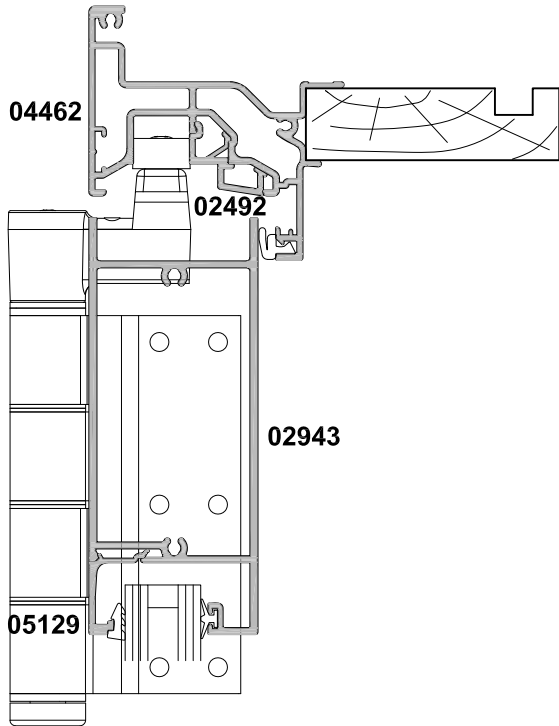

SECTION A-A

Refer to Hinge Door
Section for Vision Rail
Options

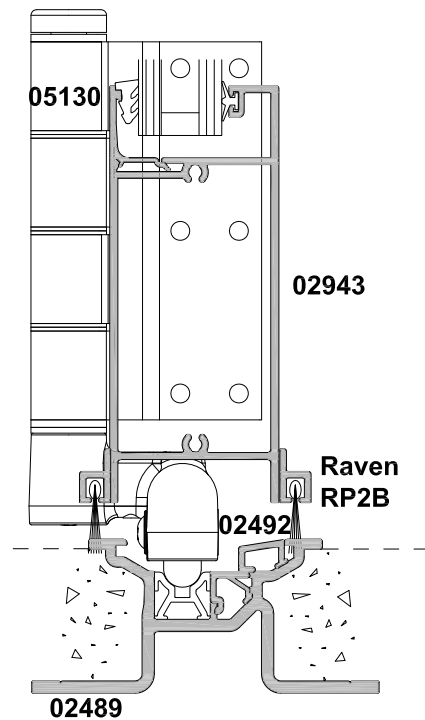
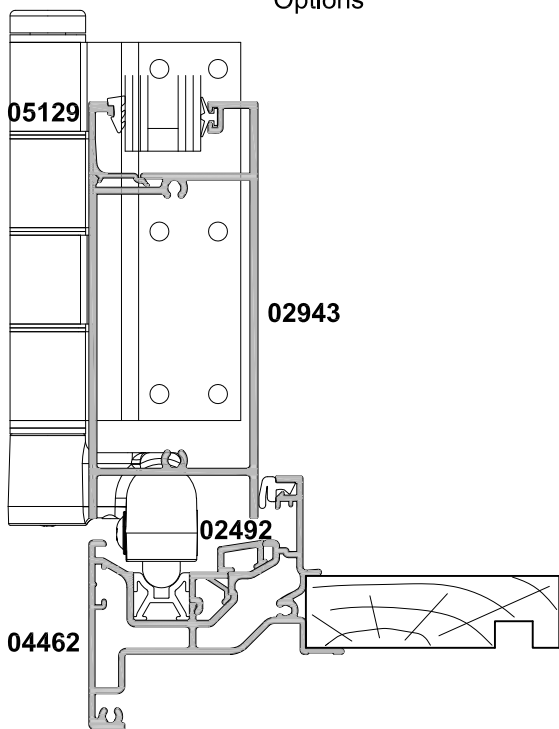

**REBATED SILL TRACK OPTION
(FOR SHELTERED LOCATIONS ONLY)**

Note - Pay particular attention
to the drainage of the track.



**METRO SERIES, BI-FOLD DOOR
OVERLIGHT TRANSM AND
OVERLIGHT COUPLING BAR
CROSS SECTION**

CAD REF. VMBD03-0

DATE
01.03.17

SCALE
1:2

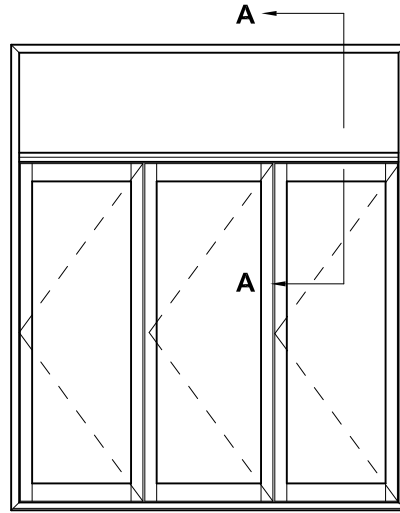
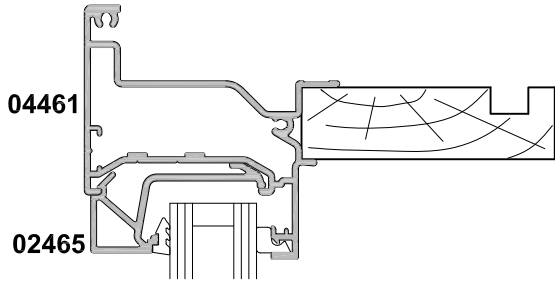

Refer to Hinged Door
section for Awning Sash
options

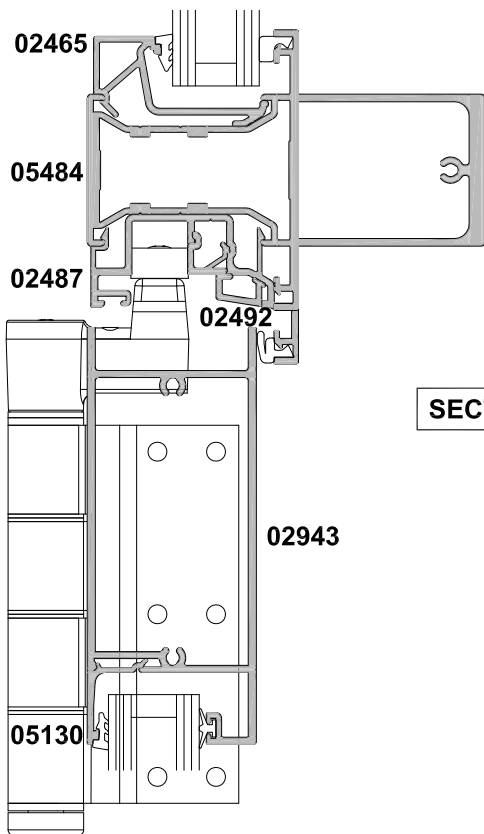

SECTION A-A

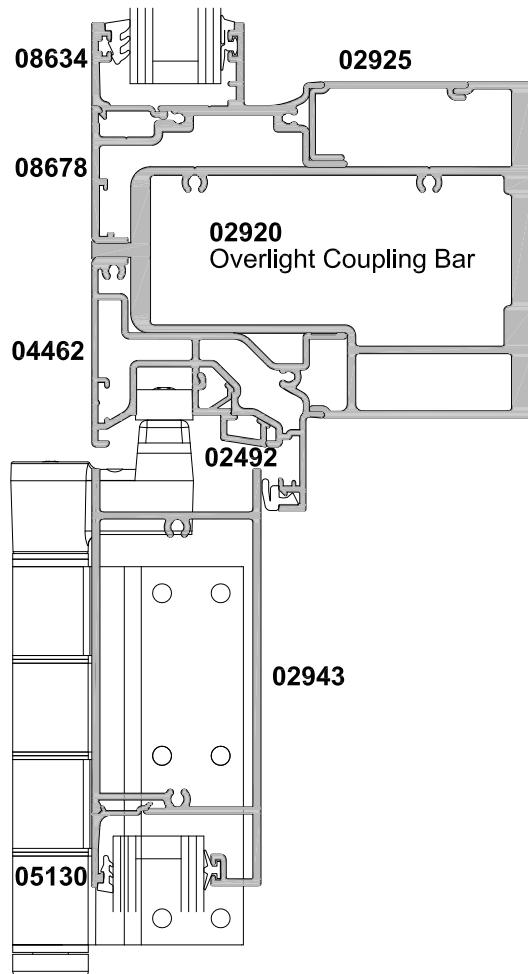

OVERLIGHT TRANSM OPTION

HEAVY DUTY COUPLING BAR OPTION



**METRO SERIES, BI-FOLD DOOR
THREE PANEL OPEN OUT DOOR
SHOWING PANEL GLAZING OPTIONS
CROSS SECTION**

CAD REF. VMBD04-0

DATE
01.03.17

SCALE
1:2

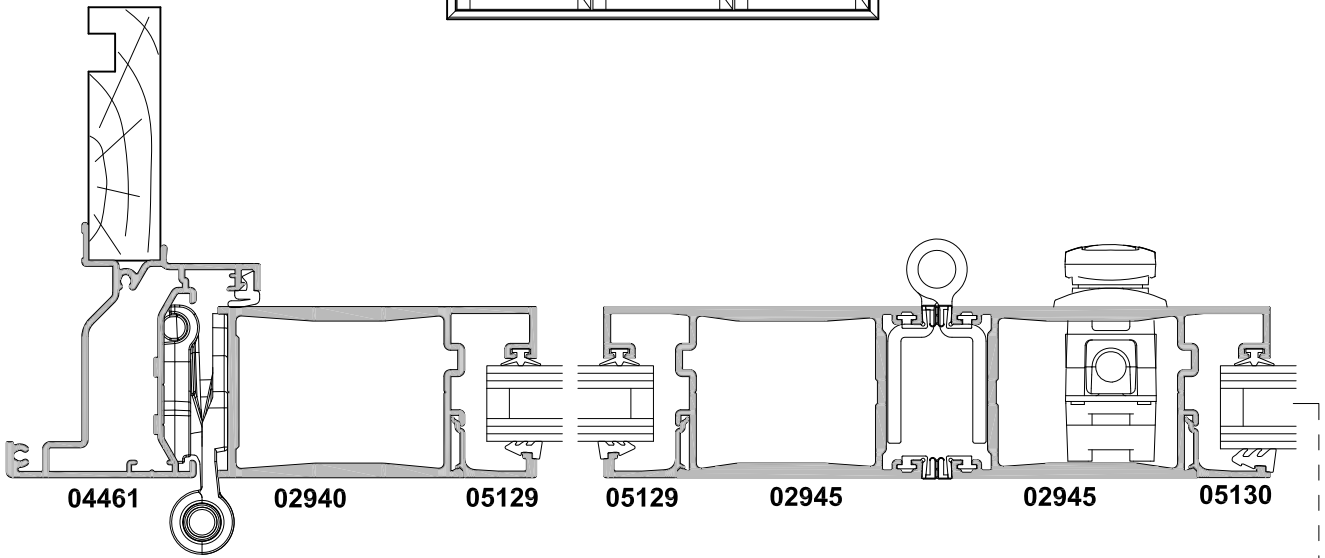
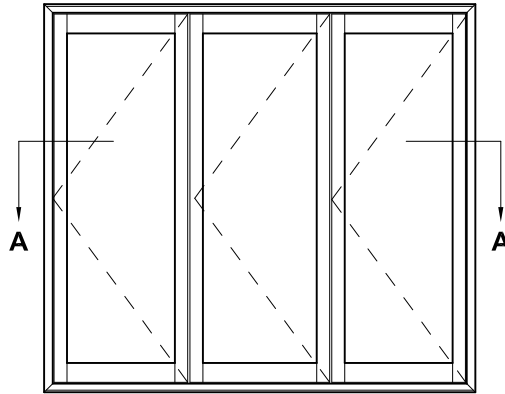

SECTION A-A

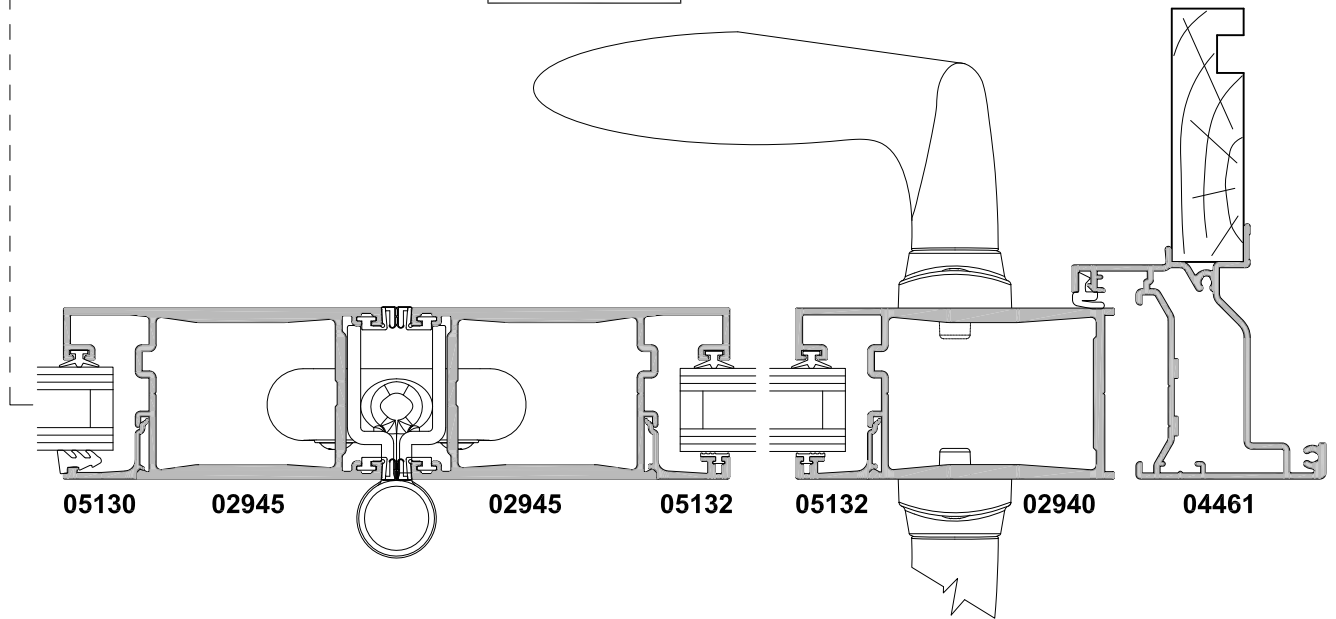



**METRO SERIES
BI-FOLD DOOR
MEETING STILES
CROSS SECTION**

CAD REF. VMBD05-0

DATE
01.03.17

SCALE
1:2

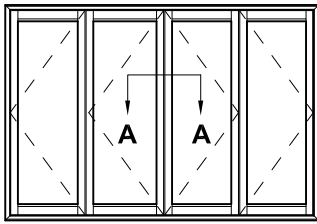

2 + 2 Panel

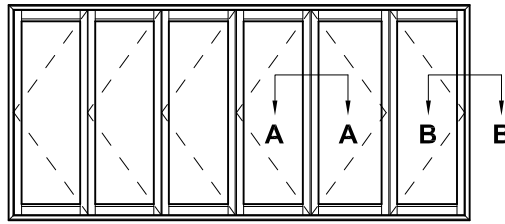

2 + 4 Panel

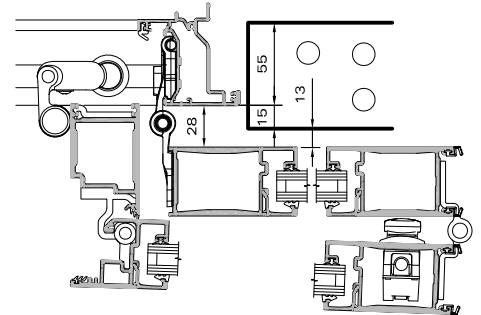

SECTION B-B

Scale: NTS

STANDARD STILE
(Any side with even number of panels)

LAY-BACK STILE OPTION
(Two panel sides only)

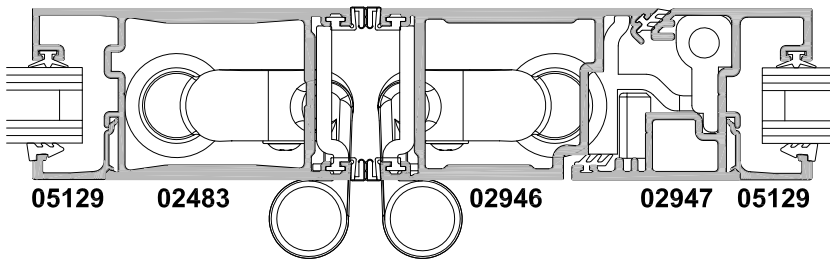

SECTION A-A

Lay-Back Installation Restrictions

When the Lay-Back panels are opened fully they sit 28mm off the front face of the frame. For the vast majority of cladding options, this will not be an issue, but in the following options it will be:

- Brick Veneer
- Recessed EIFS (plaster clad Poly)
- Concrete Block
- Precast Concrete Panel

In these Claddings the frame will need to be installed with the facings over the face of the cladding, or recessed no more than 15mm as shown (to provide a minimum 13mm clearance when open).

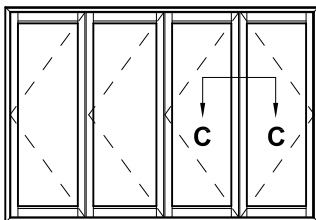

3 + 1 Panel

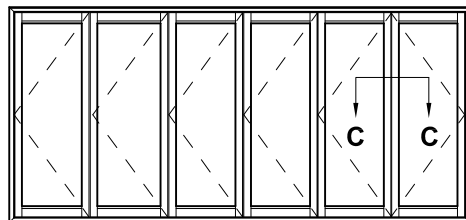

5 + 1 Panel

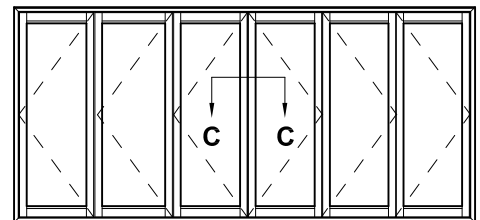

3 + 3 Panel

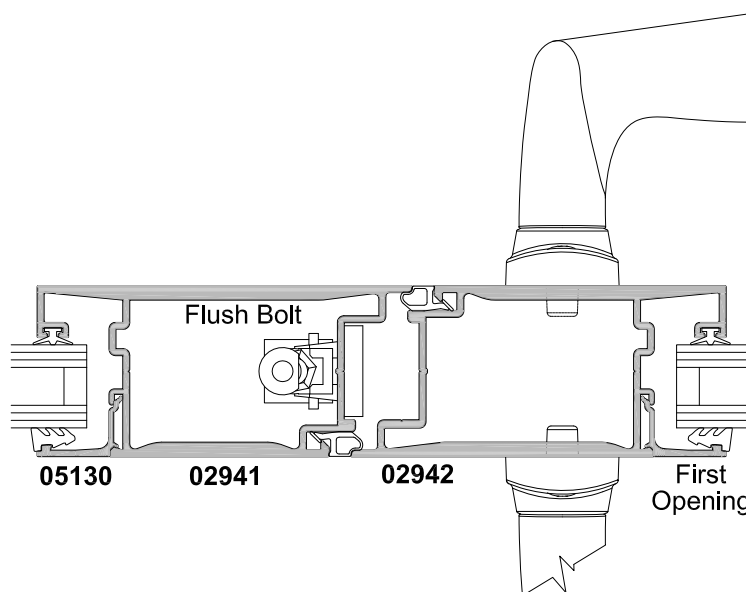

SECTION C-C



**METRO SERIES
BI-FOLD DOOR
MEETING STILES
CROSS SECTION**

CAD REF. VMBD06-0

DATE
01.03.17

SCALE
1:2

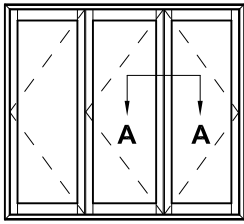

2 + 1 Panel

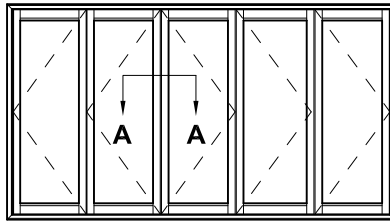

2 + 3 Panel

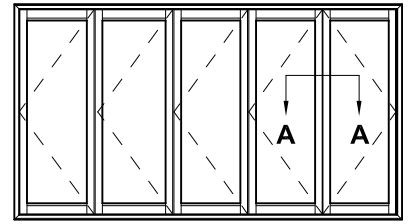

4 + 1 Panel

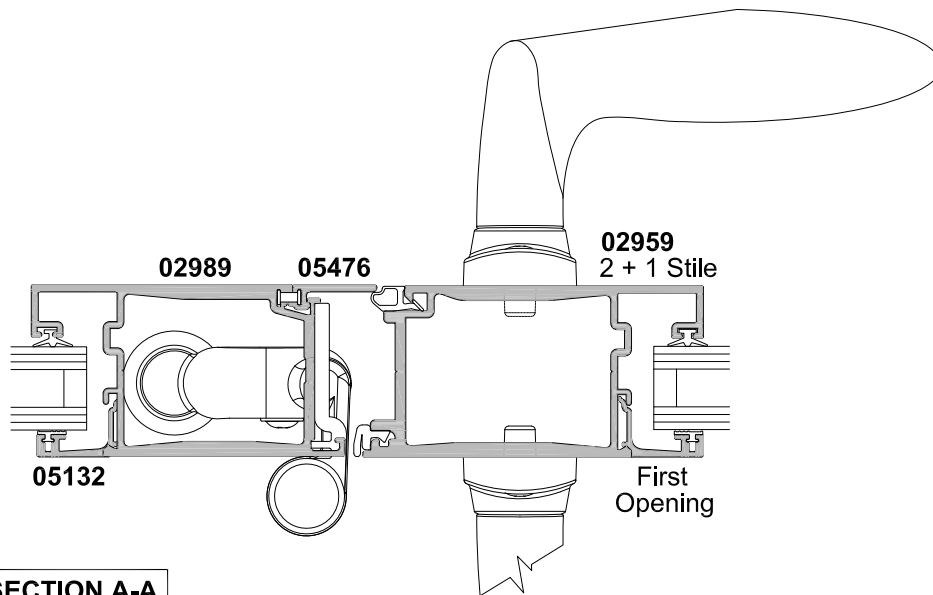

**SECTION A-A
STANDARD BI-FOLD PANELS**

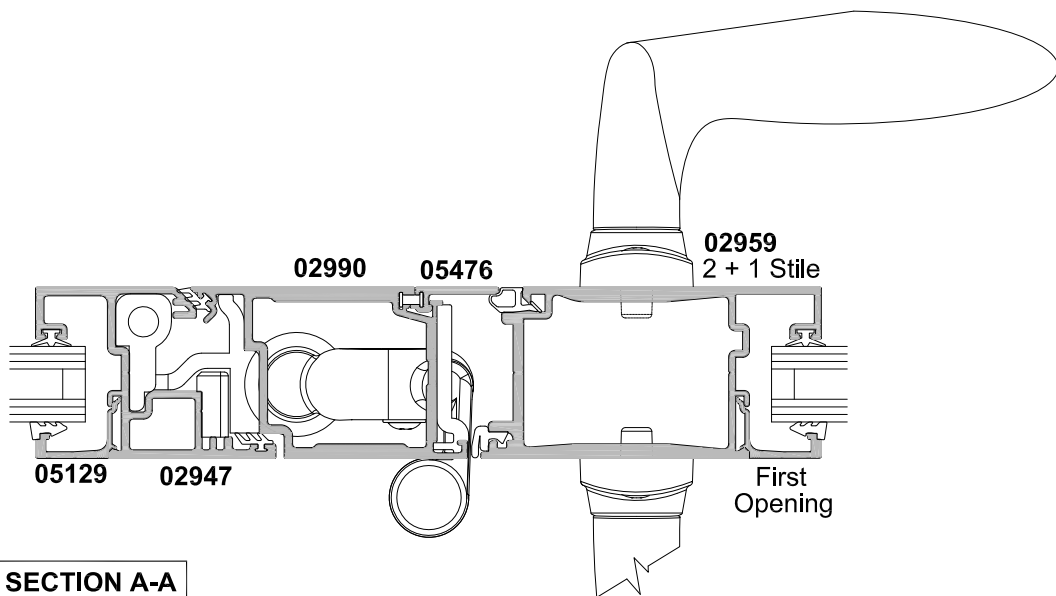

**SECTION A-A
LAY-BACK BI-FOLD PANELS
(Lay-Back Function on Two panel sides only)**



**METRO SERIES
BI-FOLD DOOR
OPEN IN VERTICAL SECTIONAL DETAILS
CROSS SECTION**

CAD REF. VMBD07-0

DATE
01.03.17

SCALE
1:2

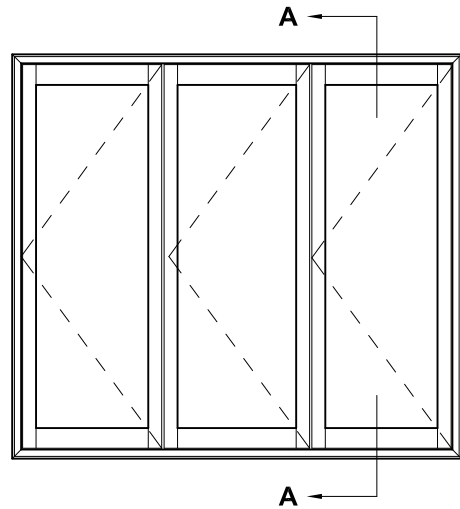
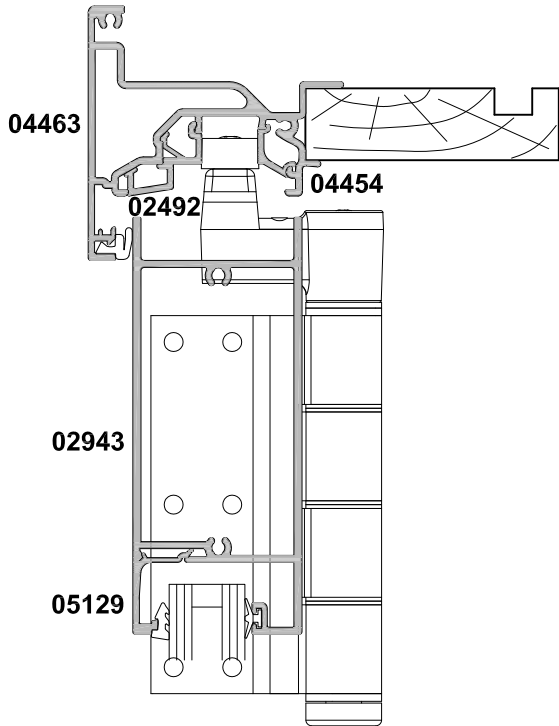

SECTION A-A

Refer to Hinge Door
Section for Vision Rail
Options

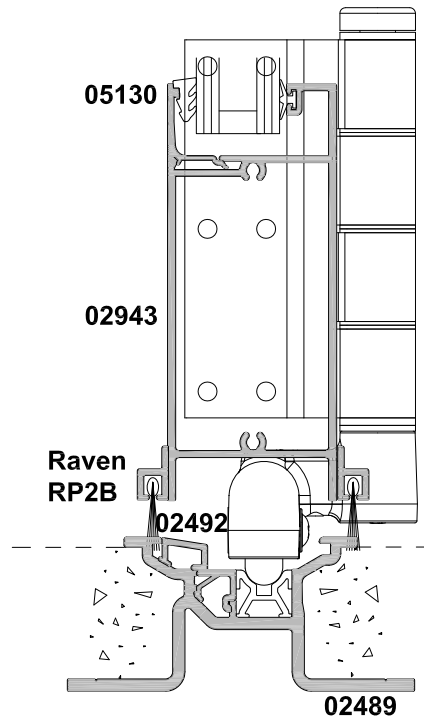
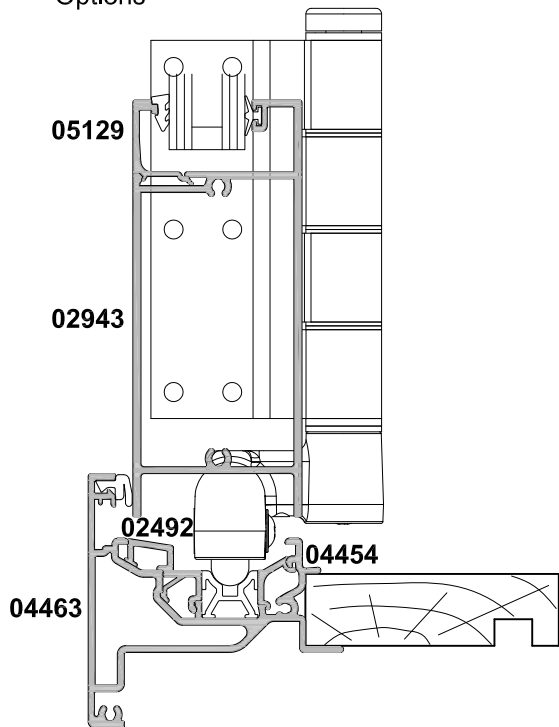

**REBATED SILL TRACK OPTION
(FOR SHELTERED LOCATIONS ONLY)**

Note - Pay particular attention
to the drainage of the track.



METRO SERIES
BI-FOLD THREE PANEL OPEN IN DOOR
SHOWING PANEL GLAZING OPTIONS
CROSS SECTION

CAD REF. VMBD08-0

DATE
01.03.17

SCALE
1:2

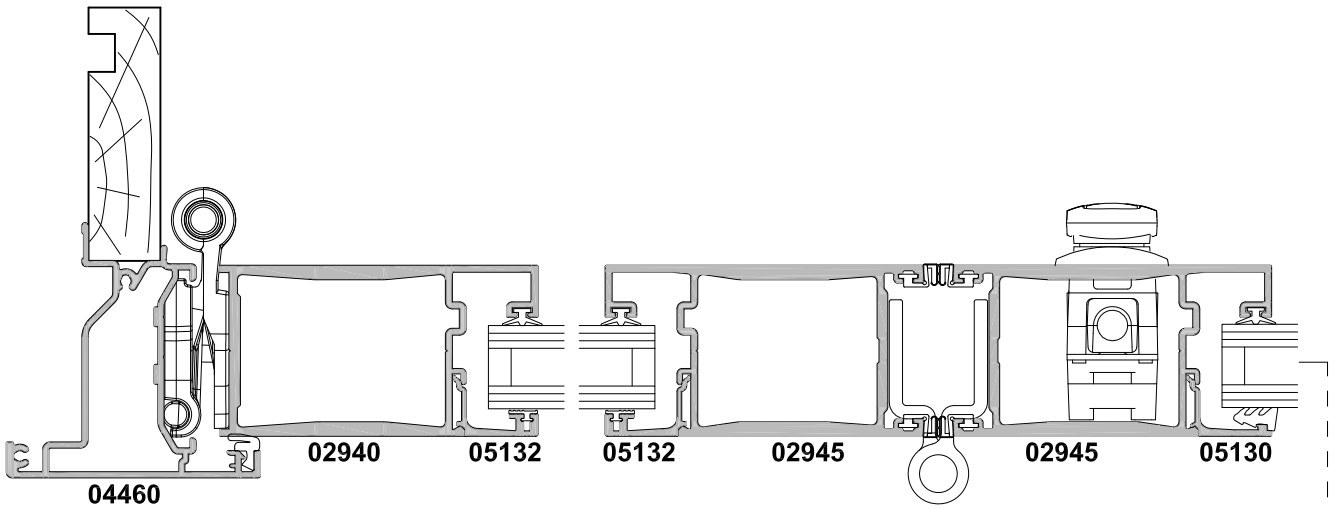
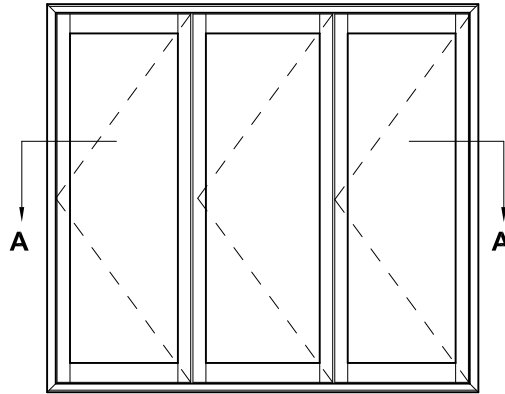

SECTION A-A

