



**KLIMA SERIES ALUCLIP
AWNING WINDOW, SASH OPEN OUT
CROSS SECTION**

CAD REF. VKAW05-0

DATE
01.06.20

SCALE
1:2

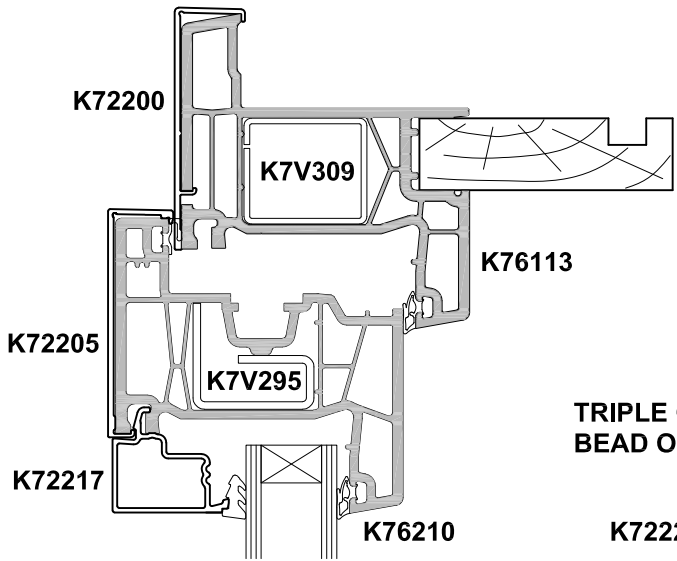

SECTION A-A

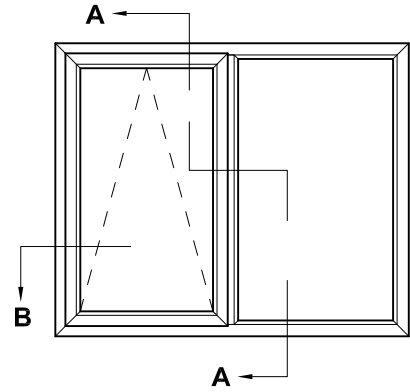

**TRIPLE GLAZING
BEAD OPTION**

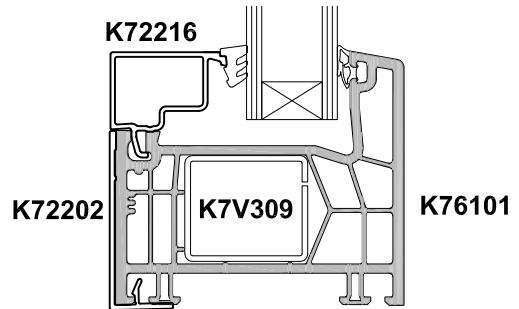
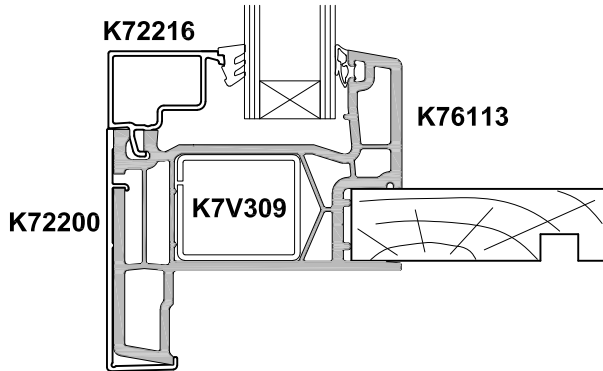
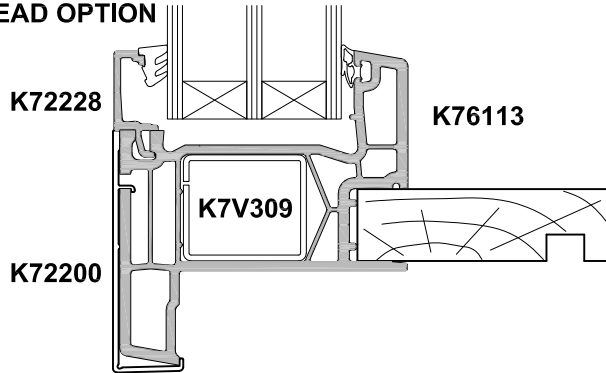

CHAIR FRAME OPTION

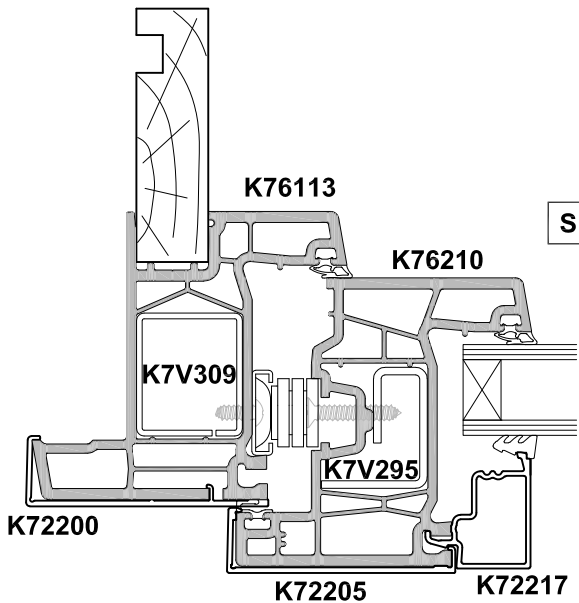

SECTION B-B

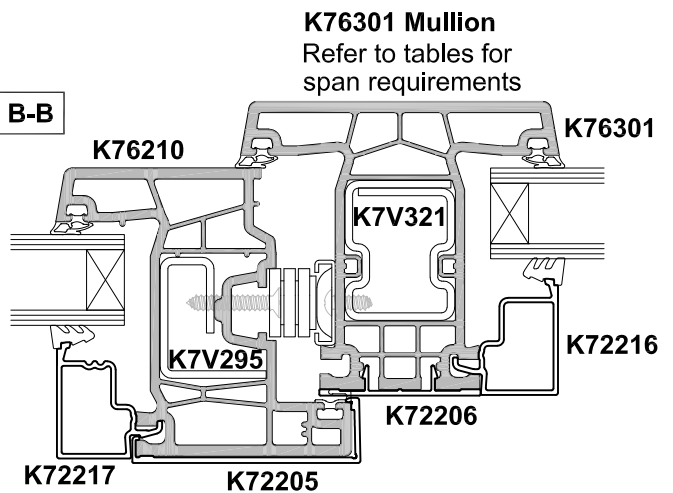

K76301 Mullion
Refer to tables for span requirements