



**AWNING WINDOW
90° AND 135° CORNER POSTS AND
LINER ADAPTORS
CROSS SECTION**

CAD REF. VAW05-0

DATE
01.04.19

SCALE
1:2

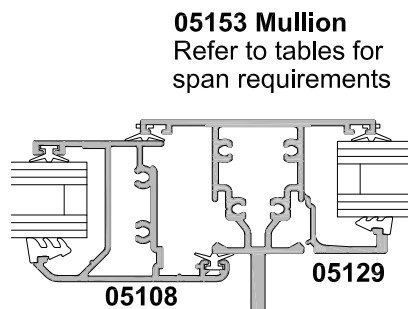
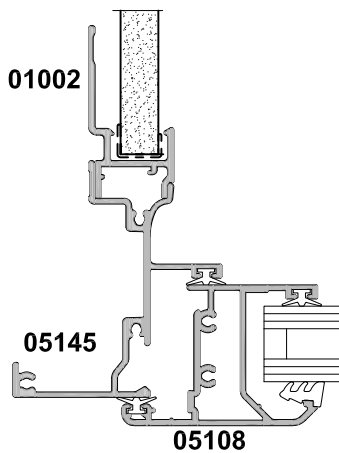
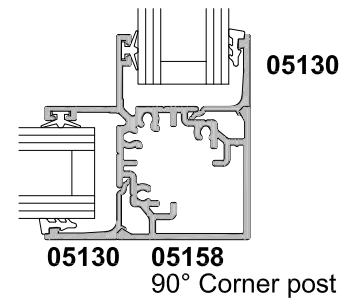
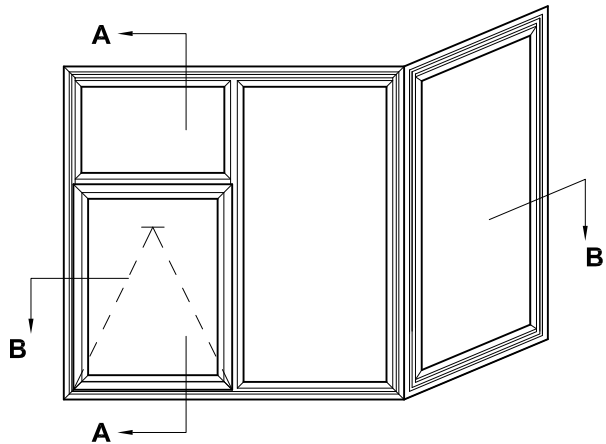
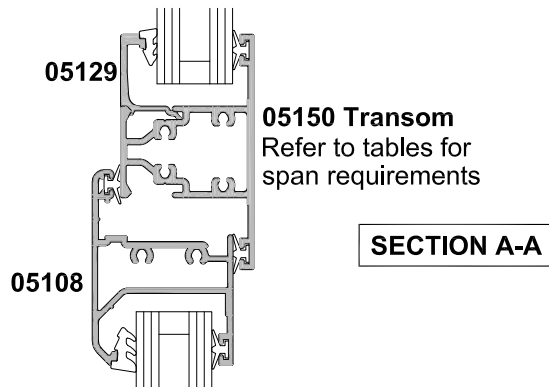
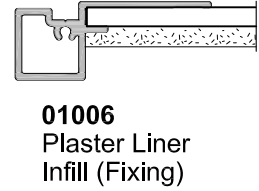
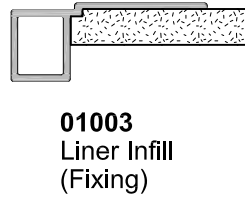
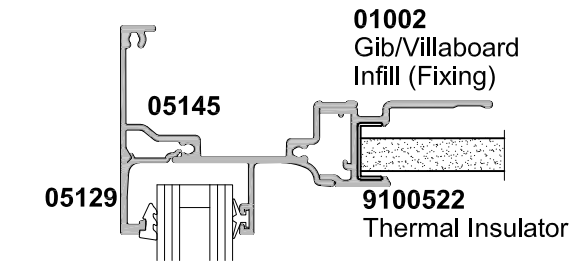

SECTION B-B

