



INT&RIOR SYSTEMS

creating quality ambient spaces

CBI GRID

SEISMIC DESIGN OF SUSPENDED CEILING

.....
MAY 2015
.....



Book a CPD seminar on Acoustics and/or Seismic
Design at your office/ practice:
0800 666 556
info@tr-interiorsystems.co.nz

These Guidelines are intended to provide a reliable basis for the seismic design of seismic ceilings based on the present state of knowledge, laboratory and analytical research, and the engineering judgments of persons with substantial knowledge in the design and seismic behaviour of suspended ceilings. When properly implemented, these Guidelines should permit design of suspended ceilings that are capable of seismic performance equivalent or superior to that attainable by design in accordance with present prescriptive Building Code provisions.



NEW ZEALAND INSTITUTE OF
ARCHITECTS
INCORPORATED
APPROVED CPD PROVIDER



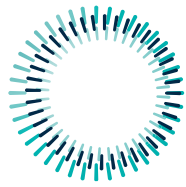

INT&RIOR SYSTEMS

creating quality ambient spaces

Welcome:

At T & R Interior Systems we aim to provide designers with the knowledge, products and tools to create acoustically successful, quality ambient spaces. We provide safe, well-tested products. We offer friendly service with integrity whilst sharing our knowledge and being a thought leader in the industry.

We are supporters of the International Living Future Institute and strive to create more sustainable building environments.

We specialise in systems. The T & R Interior Systems range of products include:

- Eclipse Aluminium Partitioning Suite
- Daiken Mineral Fibre Ceiling Tiles
- C Max High Performance Acoustic Glass Wool Tiles
- Innovative Acoustic Wall and Ceiling Panels
- CBI Heavy Duty Seismic Grid
- We also supply other acoustic products, insulation, steel studs and battens.

We offer a friendly personalised service with branches in Auckland, Christchurch and the Head Office based in Wellington.

We welcome your enquiries and are more than happy to assist with your design decisions.

COPYRIGHT: The T & R Seismic System has been developed in conjunction with BVT Engineers, the University of Canterbury and T & R Interior Systems.

It remains the intellectual property of
T & R Interior Systems and may not be used with other products.

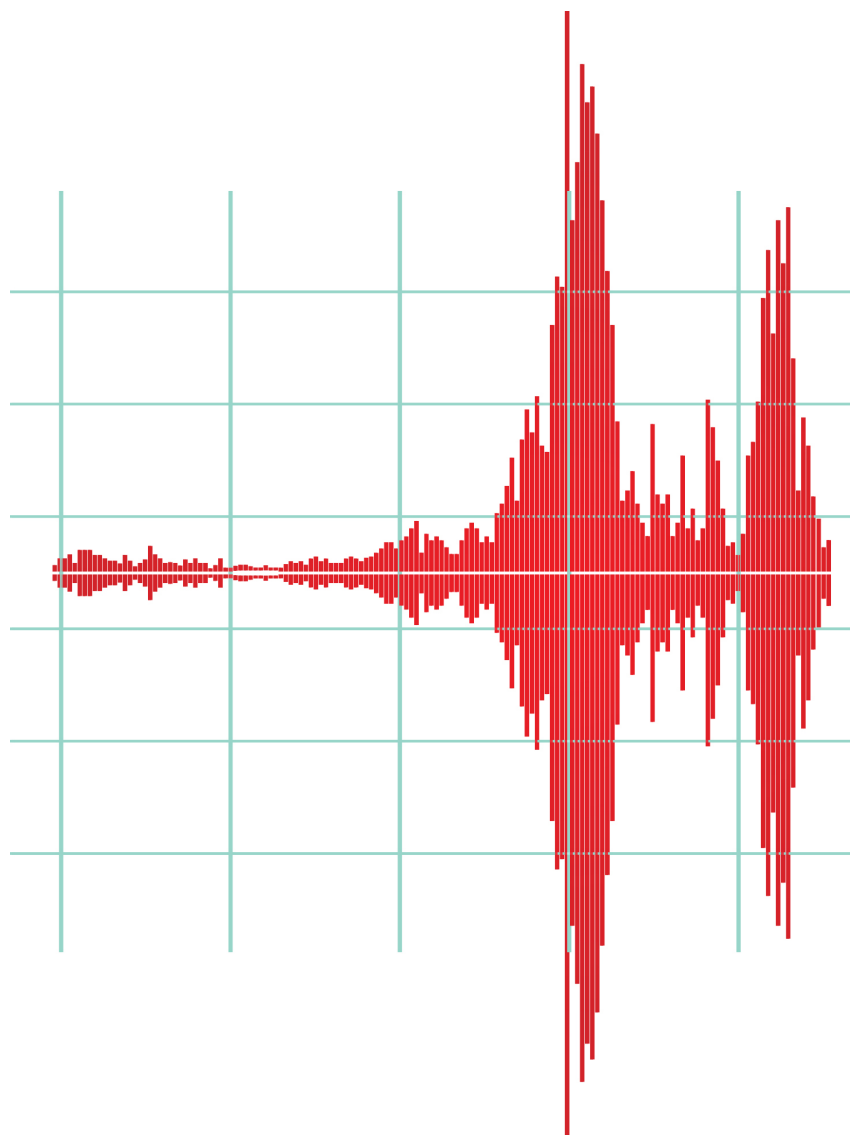

CONTENTS

T & R Interior Systems CBI Grid



SECTION 1	SEISMIC DESIGN THEORY
SECTION 2	CBI GRID
SECTION 3	T & R SEISMIC SYSTEM
SECTION 4	DETAIL DRAWINGS
SECTION 5	DESIGN CALCULATOR

Wellington Head Office
12 Glover St., Ngauranga
Wellington 6035

PO Box 38533
Wellington Mail Centre 5045

/t/ 04 499 5915
/f/ 04 499 5916

Auckland
19 - 21 Fairfax Ave,
Penrose, Auckland 1061

PO Box 112360,
Penrose, Auckland 1642

/t/ 09 571 0395
/f/ 09 571 0376

Christchurch
69 Disraeli St., Addington
Christchurch 8023

PO Box 7197
Christchurch 8240

/t/ 03 366 2507
/f/ 03 366 2508



0800 666 556
www.tr-interiorsystems.co.nz



INT&RIOR SYSTEMS
creating quality ambient spaces



A modern office interior featuring two bright blue armchairs and a round glass coffee table with a gold-colored metal base. The room has large glass windows and a glass partition wall. The ceiling is a white grid with recessed lighting. The overall atmosphere is clean and professional.

Seismic Design Theory

Introduction

The industry is under increasing pressure to assure seismic compliance on current and future construction projects.

While full compliance with seismic requirements will add cost, it will limit damage, reduce repair costs and reduce the time to re-occupy post event. Furthermore it is now a legislative requirement for Code of Compliance Certificates and pending Health and Safety Laws. The new laws, expected to come into effect later 2015 affect those who are upstream from the workplace (for example designers, engineers, manufacturers, suppliers or installers). Specifically they have a duty to ensure, so far as is reasonably practicable, that the work they do or the things they provide to the workplace don't create health and safety risks.

Because every building is different, there is no standard seismic restraint solution to address site, location, form and function. The scope of seismic restraint and related engineering work that will be required will not be known until the ceiling design is completed. The T & R Seismic System will provide a solution for buildings with an Importance Level of 3 and below. A suitably qualified Chartered Professional Engineer will be required for Importance Levels 4 & 5.

It is imperative that mechanical services, sprinkler systems, electrical and suspended ceiling design are all co-ordinated at appropriate stages.

Seismic Design Considerations

- Codes: AS/NZS 2785: 2000 and NZS 1170.5: 2004
- Grid Weight
- Edge Details (wall to ceiling junction)
- Tile profile (Diaphragm Concept)
- Services
- Partition Walls
- Bracing

Suspended Ceilings

Typically, seismic design is only required for suspended ceilings. A direct fix plasterboard ceiling has enough rigidity to resist seismic loads and typically failure (cracking) only occurs at wall to ceiling joints. (Refer the manufacturers specs for control of cracking etc) This guide therefore is relevant to the design of two way exposed/concealed ceiling grids and clarifies the design concept of the required bracing.

Two way exposed/concealed Grid

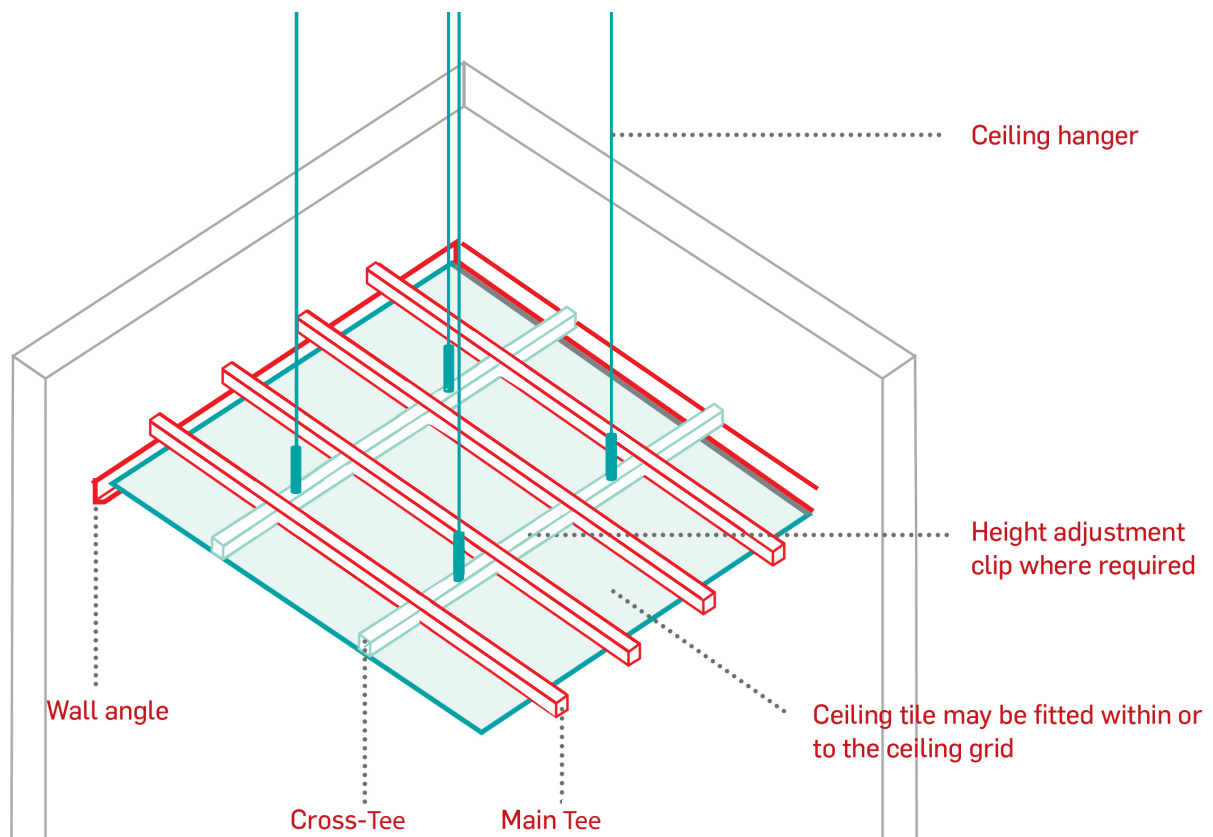



There are two types of Ceiling failure:

- Tiles Popping Out
- Cascade failure where large sections of the grid collapse



INT&RIOR SYSTEMS
creating quality ambient spaces



0800 666 556
www.tr-interiorsystems.co.nz

Relevant Codes

For suspended ceiling installations in New Zealand, seismic loads need to be considered to comply with AS/NZS 2785: 2000 - Suspended Ceilings, Design and Installation and AS/NZS 1170: 2002.

Clause B1 Structure of the Building Code requires that all building elements must have a low probability of failure when exposed to loads likely to be experienced within their lifetime.

Ceilings must comply with the New Zealand Building Code and with all legislative requirements. Regardless of past industry practice it is not acceptable to treat seismic restraints and related structural engineering design, monitoring and certification as if they were optional.

Part Categories

The categorisation of a ceiling depends on the expected failure modes. The level of seismic demand on the ceiling system should be calculated in accordance with NZS 1170.5:2004 section 8 (Requirements for parts and components). This classifies building parts under seven categories, ranging from P.2 to P.7. The categories most commonly used for suspended ceilings are either P.3 or P.7.

Category	Criteria		Structure Limit State
P.3	Part representing a hazard to individual life within the structure	Part weighing more than 10kg, and be able to fall more than 3 meters onto a publicly accessible area	ULS Ultimate Limit State
P.7	All other parts		SLS1 Serviceability Limit State

ULS = Specifically, for earthquake actions this shall mean avoidance of collapse of the structural system or parts of the structure representing a hazard to human life inside and outside the structure necessary for the building evacuation.

SLS1 - The structure and the non-structural components do not require repair after the SLS1 earthquake

The T& R Seismic System assumes that when a ceiling system fails, it will weigh more than 10kg, taking into account that a cascade failure will see large parts of the ceiling come down. Therefore, when the ceiling height is above 3 metres, the calculator meets the requirements for ULS design.

Importance Levels

The importance level of the structure shall be determined in accordance with its occupancy and use, as given below. The Table describes, in general terms, five categories of structure and gives some examples of each. For those buildings not specifically mentioned, the designer will need to exercise judgment in assigning the appropriate level.

Structures that have multiple uses shall be assigned the highest importance level applicable for any of those uses. For any given project, the primary contractor, architect, structural engineer or project manager should be able to specify the importance level of the building.

The T & R Seismic System design guide is intended for use with structures of Importance Level (IL) 2 or 3. An engineer should be engaged for Building Importance Levels of 4 & 5.

Building Importance Levels

IL	Building Type
1	Buildings posing low risk to human life or the environment or a low economic cost should the building fail. These are typically small inhabitable buildings, such as sheds, barns and the like that are not normally occupied.
2	Buildings posing normal risk to human life or the environment or a normal economic cost, should the building fail. These are typical residential, commercial and industrial buildings.
3	Buildings of a higher level of societal benefit or importance or with higher levels of risk-significant factors to building occupants. These buildings have increased performance requirements because they may house large numbers of people, vulnerable populations or occupants with other risk factors or fulfil a role of increased importance to the local community or to society in general. (Airport terminals, principal railway stations, larger day-care, schools and colleges and healthcare facilities, correctional institutions, assembly buildings, theatres, cinemas, large retail and buildings with a gross area of more than 10,000m ²)
4	Buildings that are essential to post-disaster recovery or associated with hazardous facilities. (Civil Defence, Medical Emergency, Fire, Police and buildings containing hazardous materials)
5	Buildings whose failure poses catastrophic risk to a large area (eg. 100km ²) or a large number of people (eg. 100,000) such as Dams.

The ULS or SLS1 state of a ceiling determines the level of seismic activity that the ceiling must withstand. A structure shall be designed and constructed in such a way that it will, during its design working life (with appropriate degrees of reliability) sustain all seismic activity that is likely to occur.

Typically Suspended Ceilings will have a 5 or 50 year working life. Generally a ULS will have a working life of 50 years whereas SLS Design will have a working life of 5. This means that for an SLS1 Design, it only has to withstand a 1/25 year earthquake occurrence.

Design Working Life	Importance Level	Annual Probability of exceedance for ULS for EQs	Annual probability of exceedance for SLS1
5 Years	1	1/25	-
	2	1/250	1/25
	3	1/500	1/25
	4	1/1000	1/25
50 Years	1	1/100	-
	2	1/500	1/25
	3	1/1000	1/25
	4	1/2500	1/25

Hazard Factor

The diagram below shows the seismic zone factor maps of the new structural design standard (NZS1170.5). The new hazard model produces a greater range of hazard values over New Zealand than earlier models. The very high hazard estimates near the most active faults are well in excess of values that have been considered in previous New Zealand codes.

Zone	Hazard Factor, Z	Localities
6	0.88	Arthur's Pass, Otira, Hanmer Springs, Milford Sound
5	0.67	Harihari, Hokitika, Fox Glacier, Franz Joseph, Kaikoura, Springs Junction, Masterton, Upper Hutt, Pahiatua, Woodville, Dannevirke, Waipawa, Waipukurau Wainuiomata, Eastbourne, Wellington, Hutt Valley, Porirua, Paraparaumu, Waikanae, Otaki, Levin, Seddon, Ward, Cheviot, Wairoa, Gisborne, Napier, Hastings, Feilding, Palmerston North, Foxton, St Arnaud, Reefton, Greymouth, Te Anau, Mt Cook
4	0.44	Christchurch (Christchurch earthquake zone requires higher return period factor. The Z factor has been modified to account for this)
3	0.51	Queenstown, Arrowtown, Wanaka, Twizel, Murchison, Westport, Blenheim, Picton, Nelson, Motueka, Bulls, Marton, Taihape, Waiouru, Ohakune, Raetihi, Turangi, Taupo, Murupara, Ruatoria, Opotiki, Whakatane, Kawerau
1, 2	0.37	Other Localities

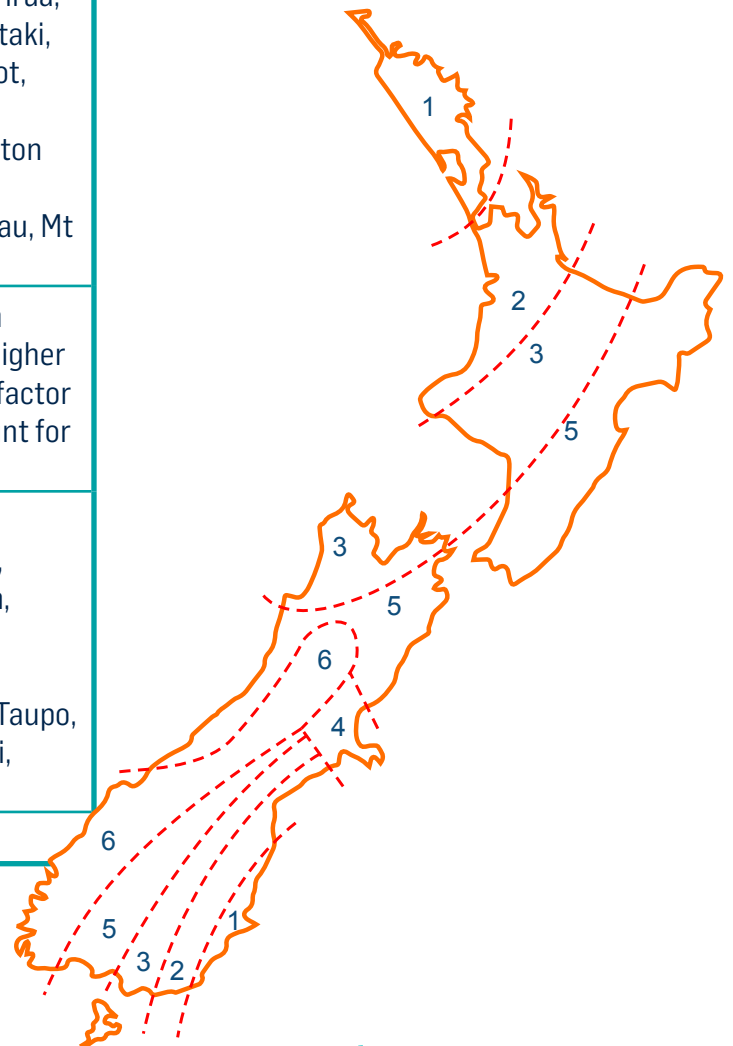

Transfer of Loads

There are two ways of approaching the design of the ceiling to wall junction: fixed or floating. If the ceiling is fixed to the perimeter wall, line loads on the grids are transferred out these walls during seismic movement. When the ceiling is floating, the ceiling moves with the structure above and is not affected by the wall movement.

Transfer of Line Loads

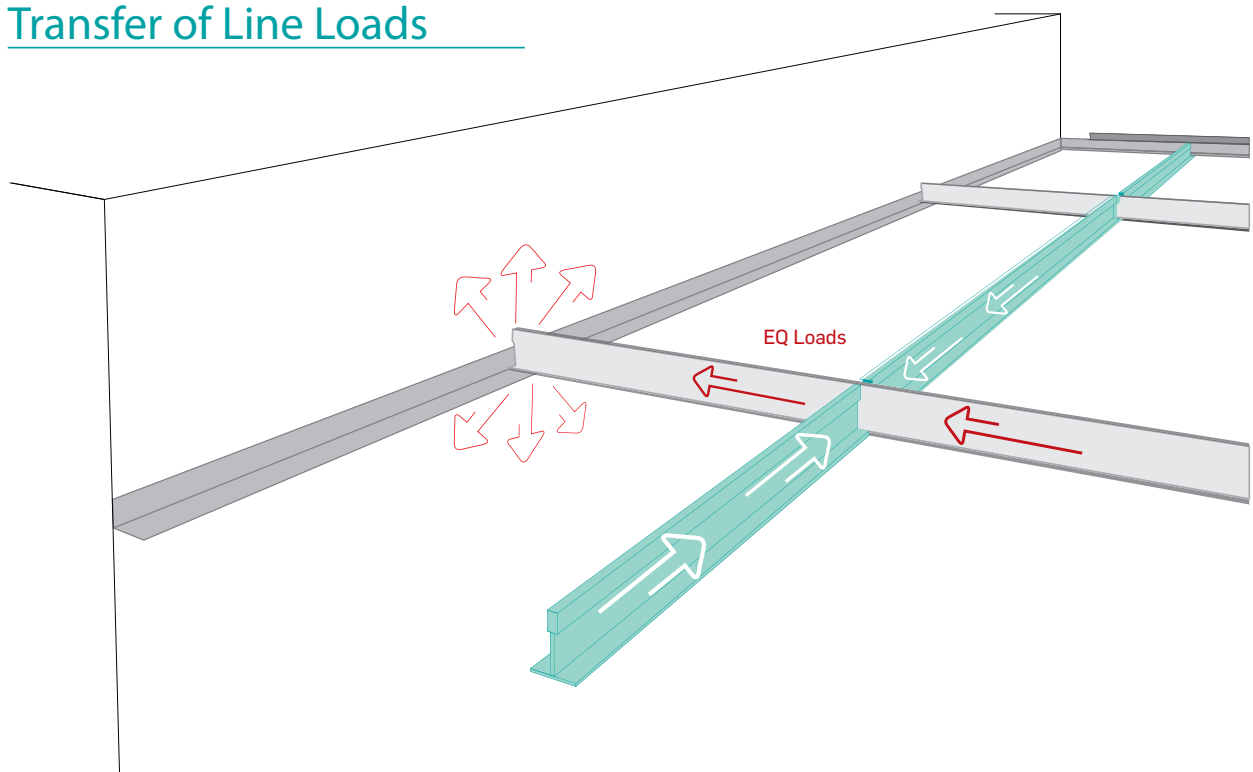

Post-Canterbury earthquake research has shown that allowance for relative motion between the ceiling and the structure must be provided. There are a number of ways to achieve this. T & R Interior Systems has developed a system with Engineers and the University of Canterbury that does not rely on clips or seismic joints, but achieves this by floating edges (depending on the ceiling size and weight, at least two edges of a ceiling must be floating) as shown on the drawings in this guide. Floating edges must also be provided around rigid objects that pass through the ceiling (e.g. columns, wall partitions, sprinklers).

Services

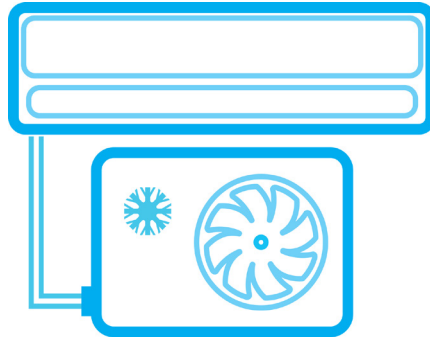

The Building Code requires that all non-structural building components must be properly restrained against seismic movement to prevent them collapsing on people, cutting off exit routes from the building, being damaged or damaging other property.

It is critical that all building components in the plenum do not impede or interfere with one another and in most cases; it is not possible to support these elements with the grid. Additional structure will be required. Refer to NZS4219 for further details.

Any services that are supported independently and that penetrate through the ceiling grid must be provided with sufficient clearance for relative movement. This is especially true for sprinkler heads. Penetrations shall have a 50mm oversize ring, sleeve or adapter through a ceiling tile to allow free movement of at least 25mm in all horizontal directions if NZS4219 is being used as the verification method. Flexible dropper design that can accommodate 25mm free movement shall be permitted as an alternative.

Failure to provide adequate clearance could result in the ceiling collapsing during a seismic event. During the Canterbury Earthquakes, ceiling failures caused by services in the plenum were overwhelming

Separation of components is required by code and allows for relative movements between services and ceiling during an earthquake

Clearances

When Bracing is required, the bracing layout and services should be coordinated. Services within the ceiling can be either braced or unbraced. Different clearances are required between braced and unbraced services

NZS 4219: 2009 is the standard specifically concerned with the seismic restraint of mechanical systems in buildings.

Condition being considered	Minimum Clearance (mm)	
	Horizontal	Vertical
Unrestrained component to unrestrained component	250	50
Unrestrained component to restrained component	150	50
Restrained component to restrained component	50	50
Penetration through structure (such as walls and floor)	50	50

NOTE - Ceiling hangers and braces are considered to be restrained components for the purposes of this table

C5.2.1

Flexible connections within the service pipes may allow penetration clearances to be reduced.

Partition Walls

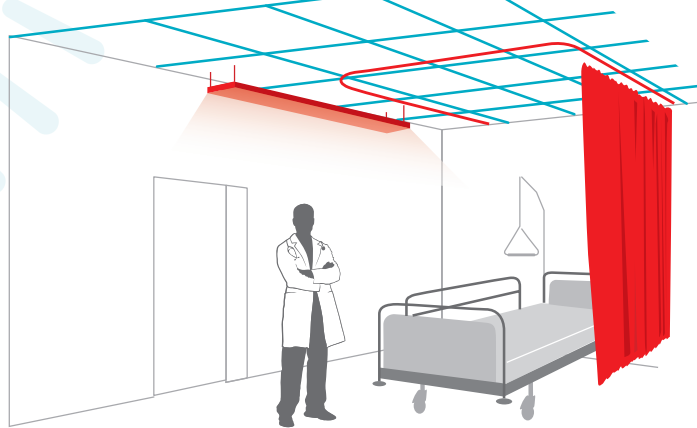

When partition walls or glazing lines are attached to the suspended ceiling, the horizontal deflection of these elements during a seismic event can cause the ceiling to collapse.

Partition walls and glazing lines need to be independently braced at all times. At a minimum of 40kg/m² these walls have the weight to create catastrophic failure when horizontal deflection occurs.

Partitions under ceilings should be braced through the ceiling with sufficient seismic gaps to allow for calculated ceiling movement. There are proprietary and generic methods to permit partition bracing.

The TRACKLOK™ system allows for horizontal deflection of the wall of up to 40mm each way, while allowing for inter-story drift of 70mm.

The TRACKLOK® unit has also been tested to allow installers to use the arms of the fly plate from 30 degrees to 60 degrees and for the unit to be rotated 30 degrees off perpendicular. This enables the installer to mitigate some service clashes and provides flexibility.

Testing has shown the TRACKLOK® unit is able to withstand the Ultimate Limit State (ULS) of 2.75kN, however when pushed to failure TRACKLOK® withstood forces of 9.9kN to 15.4kN showing that the robust nature of the unit.

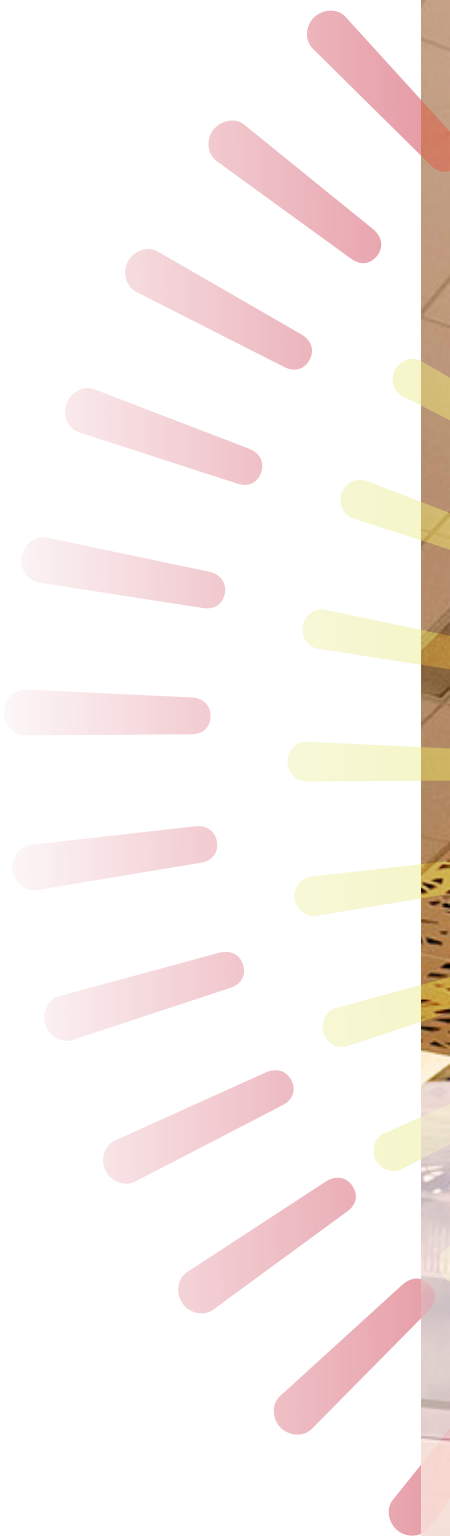



CBI Grid

CBI Grid

15 & 24mm Two Way Exposed CBI Grid

All calculations in the brochure are based on CBI Grid and may not be substituted to any other system without prior permission.

CBI Qualities

- Heavy-duty configuration with a 38mm web height to both Main & Cross Tees
- Main Tees punches at 100centres with first punch at 50mm
- Convenient punch out to both Web and Bulb for ease of suspension
- Seismically tested and proven to meet current NZ Standards
- High quality Italian design and manufacture
- 30-year system Warranty
- PS1 and PS4 are available from our Consulting Engineer as required
- Site specific ceilings will be designed to both ultimate and serviceability limit states to meet current NZ standards





Main Tee The Main Tee is manufactured from hot dipped galvanised steel in a double web, balanced tee design, in 3700mm lengths. It is finished with a pre-painted steel cap. The Main Tee is conveniently punched at 100mm centres and includes suspension points in both the bulb and web. Main tees extend from wall to wall and are the primary ceiling support. End splices allow for greater lengths. Slots along the runner side allow cross tee to connect. Hold down clips are available as required.

Cross Tee The Cross Tees are manufactured in the same configuration in 1200mm and 600mm lengths. Lay on edge detail for neatness of installation coupled with resistance to twist. They connect between main tees using interlocking tabs. The high tensile clips ensure a positive locking system for quick installation

Wall angle L-shaped pieces that fasten to the wall and support or conceal the ends of the main runners and cross tees.

Z Rail A seismic support that suspends the edge of the grid without relying on the perimeter.

Border Cut panels around the perimeter of the room. They should be greater than half of a tile to maintain balance and add visual appeal.

Wall and Column Trims

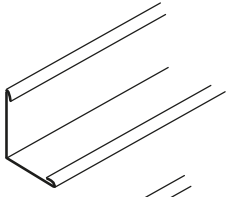

Standard Wall Angle

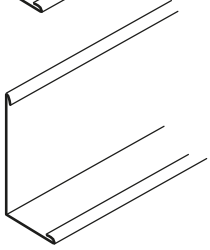

Long Leg Wall Angle

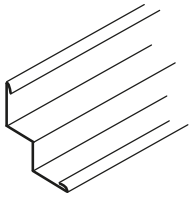

Shadowline Wall Angle
(Short Leg)

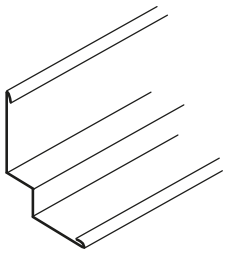

Shadowline Wall Angle
(Long Leg)

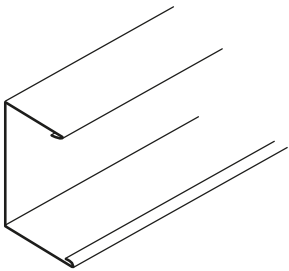

Seismic Wall Channel

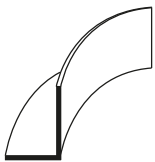

Aluminium Column and
Radius Angle Trim

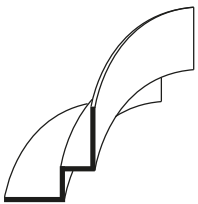

Aluminium Shadowline
Column and Radius Trim

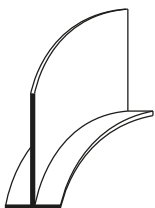

Aluminium Column and
Radius "T" Trim

CBI Grid and Related Components



Support Members + Main Tees + Cross Tees

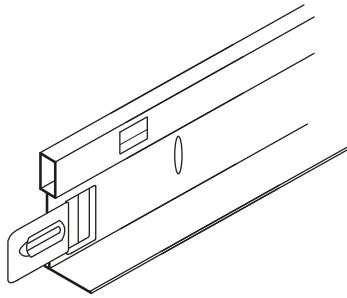

Main Tee 24mm

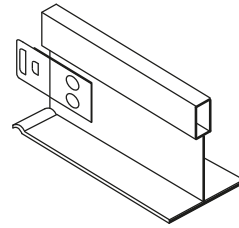

Cross Tee 24mm

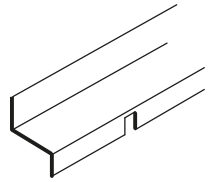

T & R Z Rail

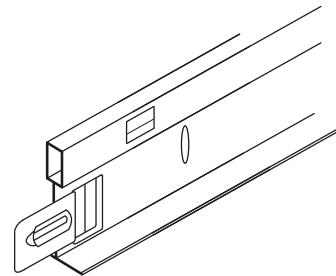

Main Tee 15mm

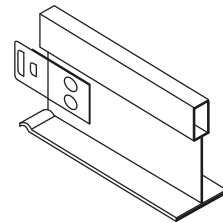

Cross Tee 15mm

Ceiling Tile Edge Details

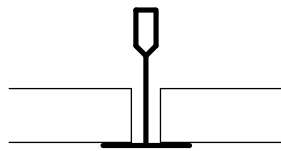

24mm Grid (Square Edge)

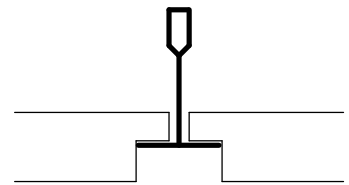

24mm Grid (Rebated Edge)

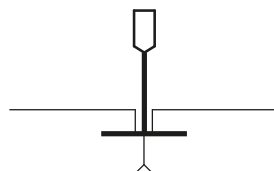

Concealed

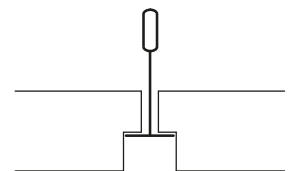

15mm Grid (Rebated Edge)

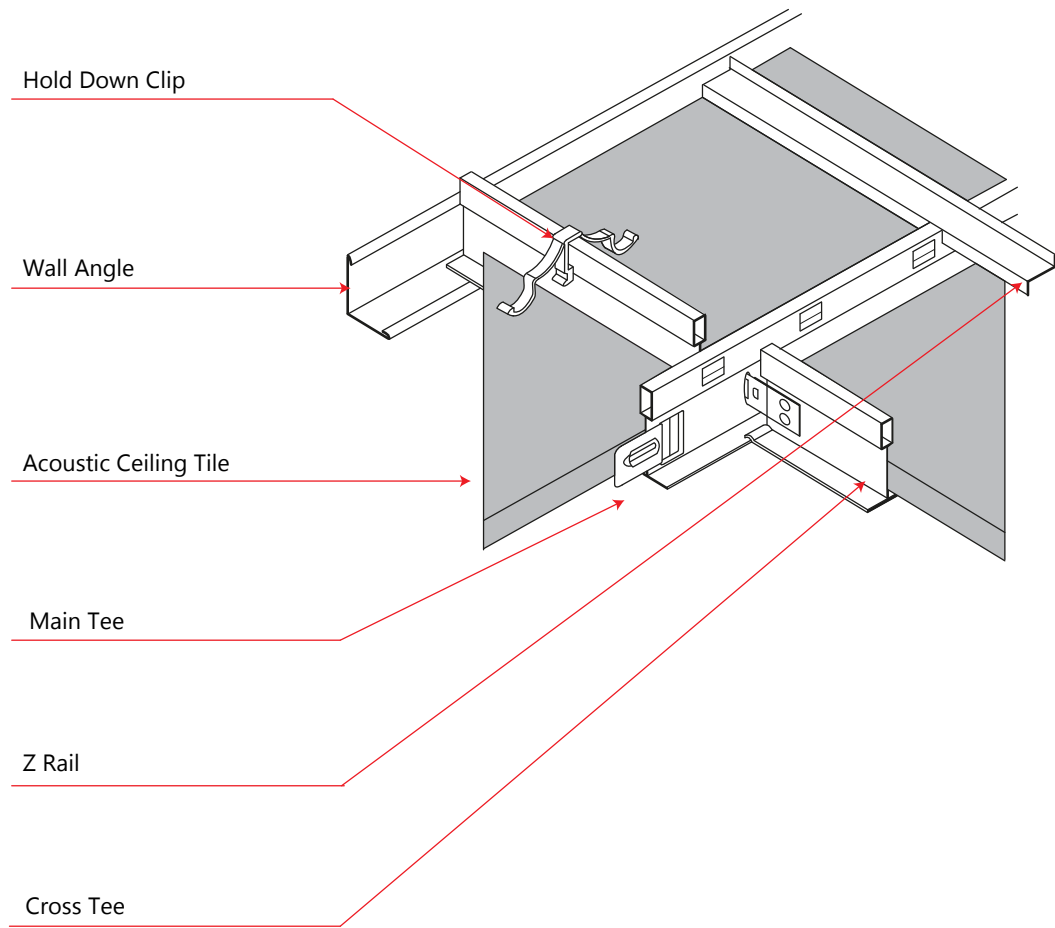

Eye Screws

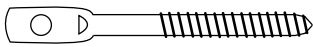

Timber
75mm, fast embedding eye screw (wire or rod)

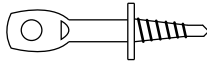

Metal Deck
0.8mm to 1.2mm BMT (wire only)

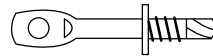

Steel Purlin
1.8mm BMT steel (wire or rod)

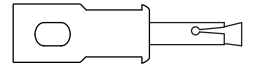

Concrete
Masonry Sleeve anchor (wire or rod)

Suspension Components

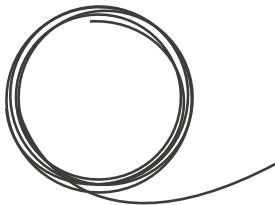

Galvanised/Braided Wire

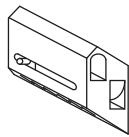

Zip Lock

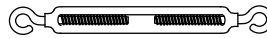

Turn Buckle

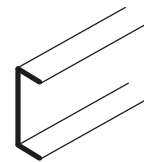

"C" Channel

Accessories: Hold Down Clips

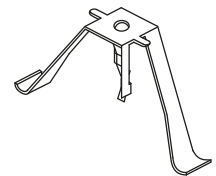
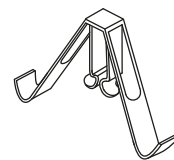
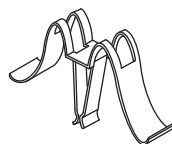
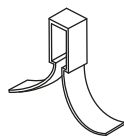
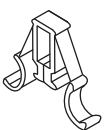





T & R Seismic System

T & R Seismic System

The T & R Seismic System has been developed in association with BVT Engineering and the University of Canterbury. It relies on the separation of the ceiling grid and perimeter walls.

The system comprises four main concepts:

CBI Heavy-Duty grid
Floating and Fixed edges
Z-Rail
Diaphragm Concept



Edge: Floating/Fixed

The T & R Seismic System advocates two methods of edge fixing. These are a mixture of fixed and floating and entirely floating.

T & R Seismic System: All sides floating

On larger ceilings where back bracing is required, the T & R Seismic systems is for all sides to be floating. Because the ceiling is not attached to the perimeter walls at any point, it moves with the structure above.

Testing has shown that where sides are fixed, the forces are transferred to the perimeter walls first and foremost, and it is only when these fixings reach capacity (and fail) that the back-bracing starts having any effect. Therefore, when back bracing is required, perimeter fixing is detrimental.

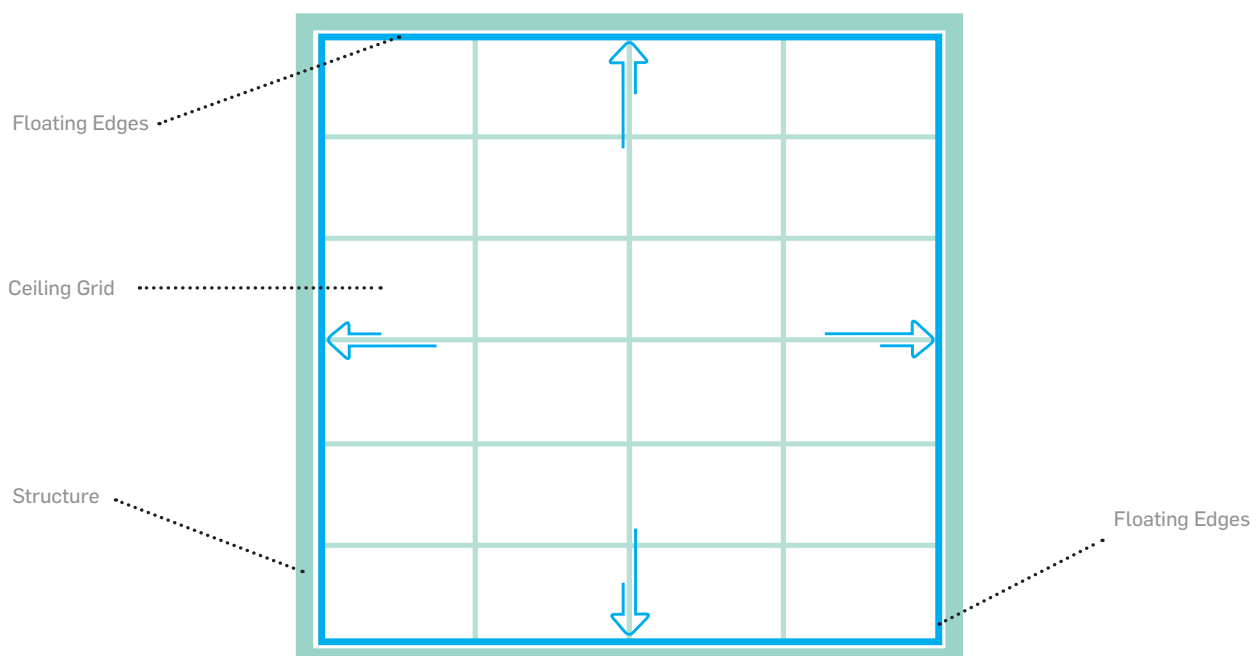

Two Sides Fixed, Two Sides Floating

The T & R Seismic System for small and medium ceilings (where no back bracing is required) prescribes that two of the four edges are to be floating. This system relies on two perimeter walls to add support and brace the ceiling, but allows movement on the opposite side to prevent the grid pulling apart or crushing under compression.

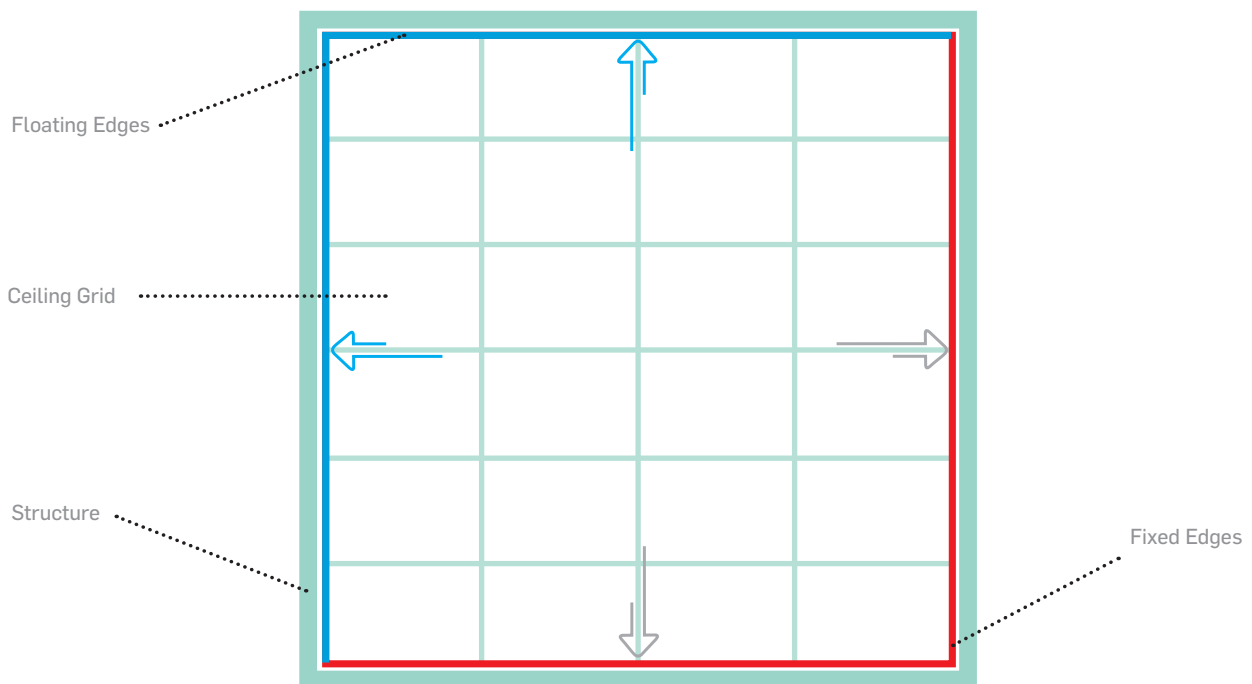

All Sides fixed

Although there are some cases where perimeter walls will not cause sufficient forces on the grid to cause damage when all edges are fixed, this can only be calculated by an engineer taking into account deflections of the walls. Therefore, the T & R Seismic System does not recommend fixing all sides, but where necessary, this should be checked by a suitably experience Chartered Professional Engineer.

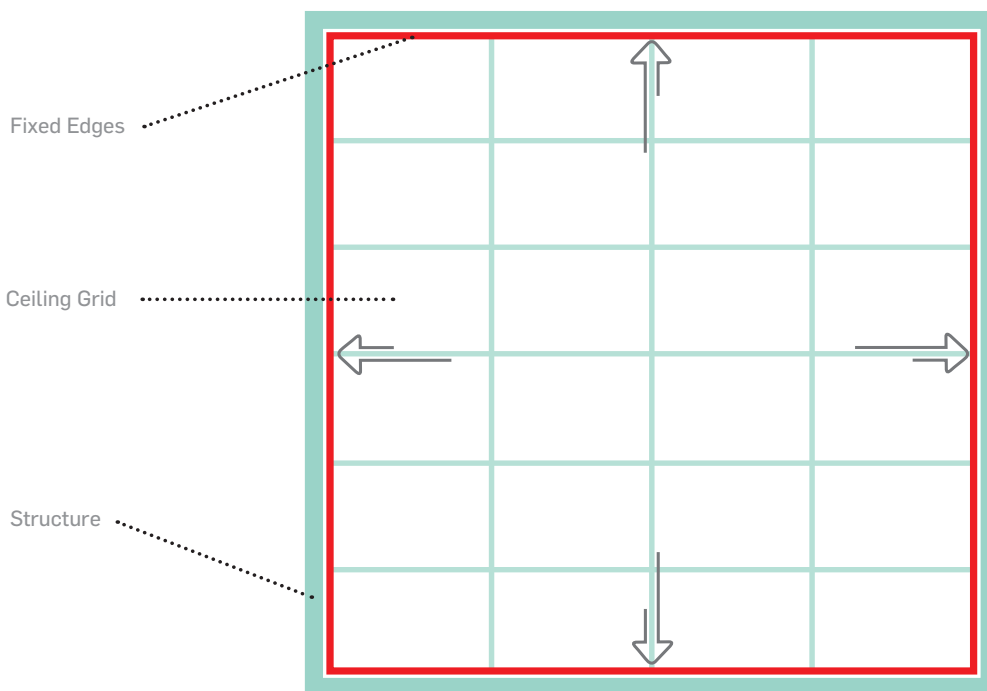

Floating Edges

The T & R Seismic System utilises a Z Rail to suspend the grid perimeter and take the dead loads to the structure above. (see drawing below). The 'Z-rail', notched at 600 centres, locks over the Tees and is attached to the grid with a rivet and is suspended independently. This creates a 'frame' around the ceiling locking it together and allows the ceiling to move with the structure above.

The Tees stop short of the wall to provide seismic clearance. A nominal 20mm is recommended but may be increased for specific design requirements and building deflection. This should be assessed on a case by case basis.

The wall trim is structurally unnecessary but provides an aesthetic cover.

As no line loads are being transferred to the wall, additional structure is not necessary within it.

T & R Seismic System specifies a nominal 20mm Seismic Space between termination of tee and the wall.
The expected deflection at ceiling height = the seismic spacing required

This should be discussed with a structural engineer.

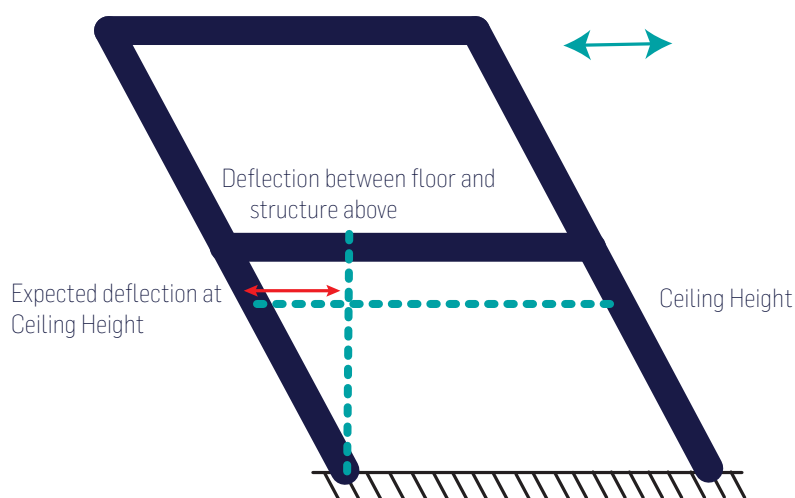

The deflection between the floor and structural deck above suspended ceiling in section.

Floating Edge Detail

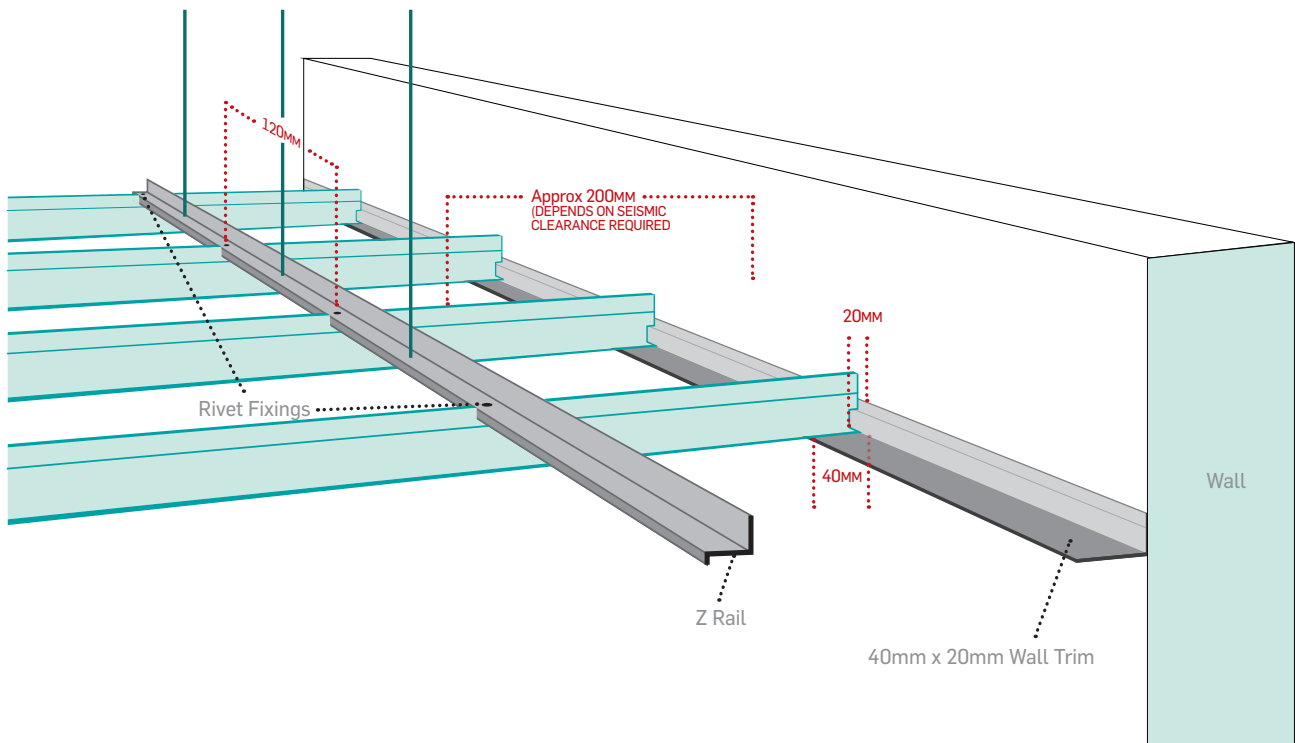

Fixed Edges

When using fixed edges, the Tee is attached to the wall trim by a rivet. The perimeter walls must have a continuous dwang at ceiling height to take the transfer of line loads.

The fixed connection is providing a structural function for the ceiling. Because this system has no back-bracing, the grid stability is provided by the fixed edges. Testing has shown that there must be screw fixings at 50mm either side of the termination of the Tees to provide sufficient structural stability for the line load transfer.

The capacity of the wall should be checked to make sure that the live loads can be withstood.

Required Transfer of Line Loads

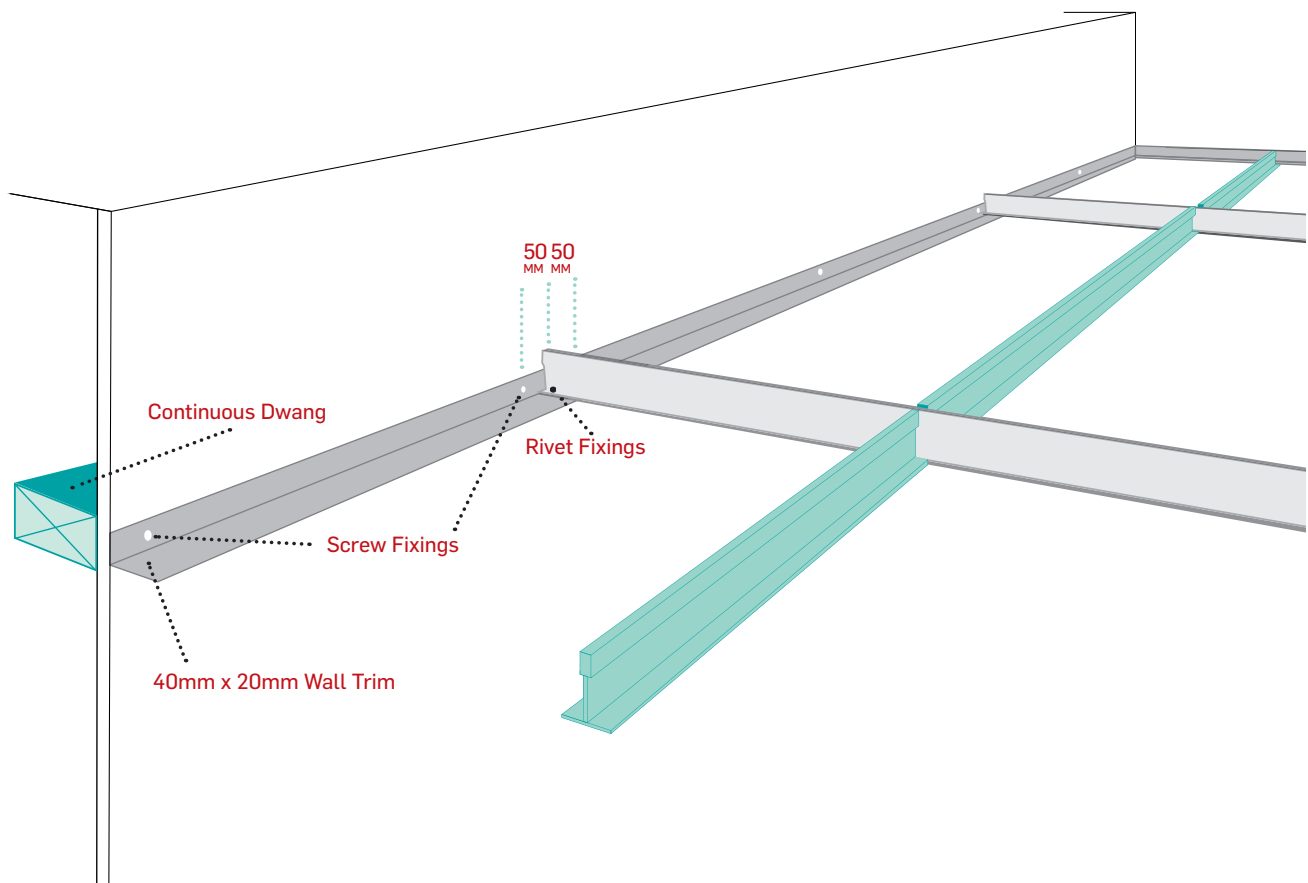

Diaphragm Concept

Testing has shown that the level of seismic strength can be increased by using reveal tiles (as per the centre diagram below). Because the tile locks around the grid, it increases stiffness of the diaphragm. This is more effective than a standard Square Edge tile.

Due to the shape of the bevelled edge tiles, they are more likely to pop out of the grid during seismic activity.

EDGE DETAIL

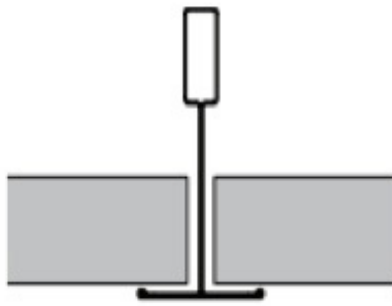

Square Edge

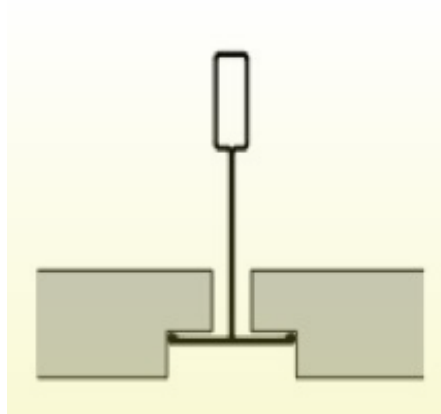

Square Edge

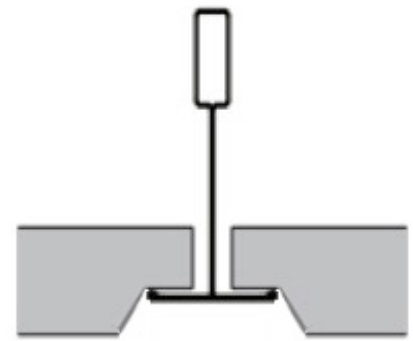

Bevelled Edge

Bracing

In New Zealand, seismic requirements for ceilings are based on:

- NZS 1170.5 - Earthquake Actions
- NZS 2785 - Suspended Ceilings, Design and Installation

Seismic bracing requirements for a suspended ceiling are a function of the geographical location of the building and its importance level. It also takes into account the height of the ceiling above floor and ground and the mass of the grid, tiles and services. The overall ceiling area determines the amount of bracing required.

There are two bracing types; bracing offered by [edge fixing to perimeter walls](#) and [back-bracing in the ceiling plenum](#).

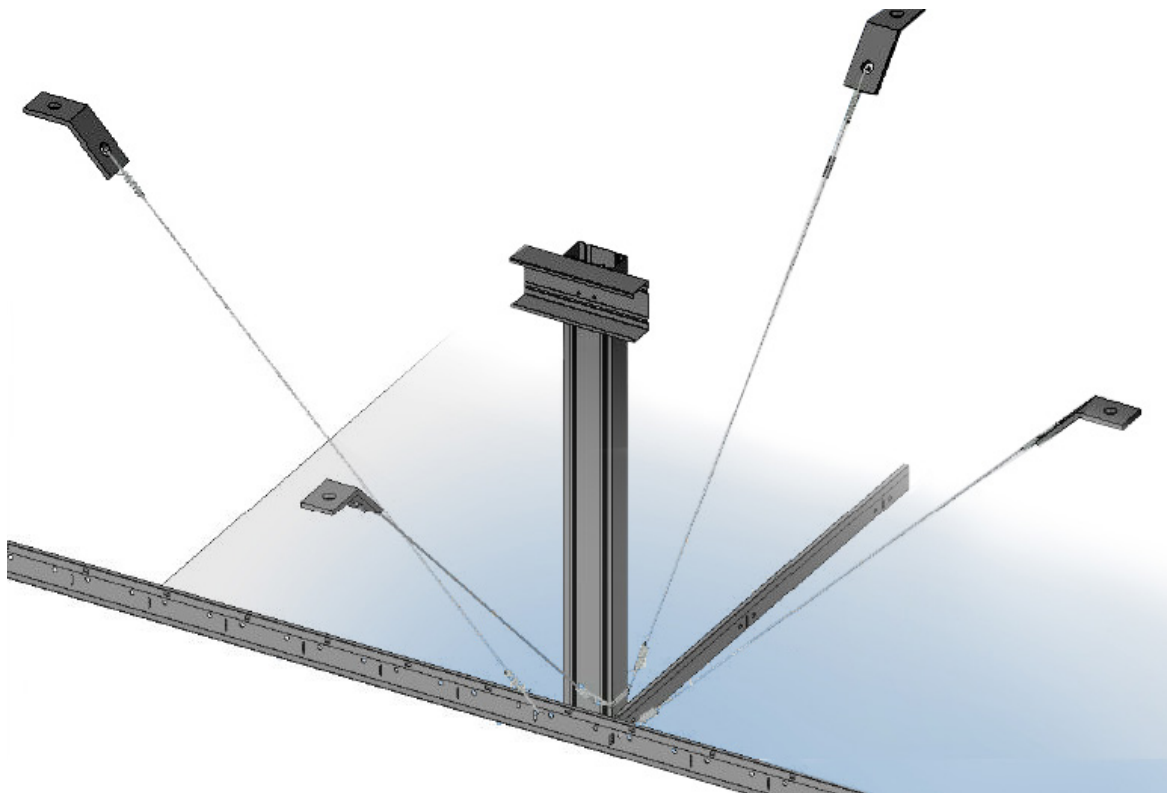

In order to determine the type and amount of bracing needed, the following are taken into consideration:

- Ceiling mass per square meter
- Ceiling height
- Plenum depth
- Ceiling area
- Seismic Force
- Spacing of grid
- Location in New Zealand
- Part Category
- Wall capacity
- Fixing Types
- Capacity of Brace design

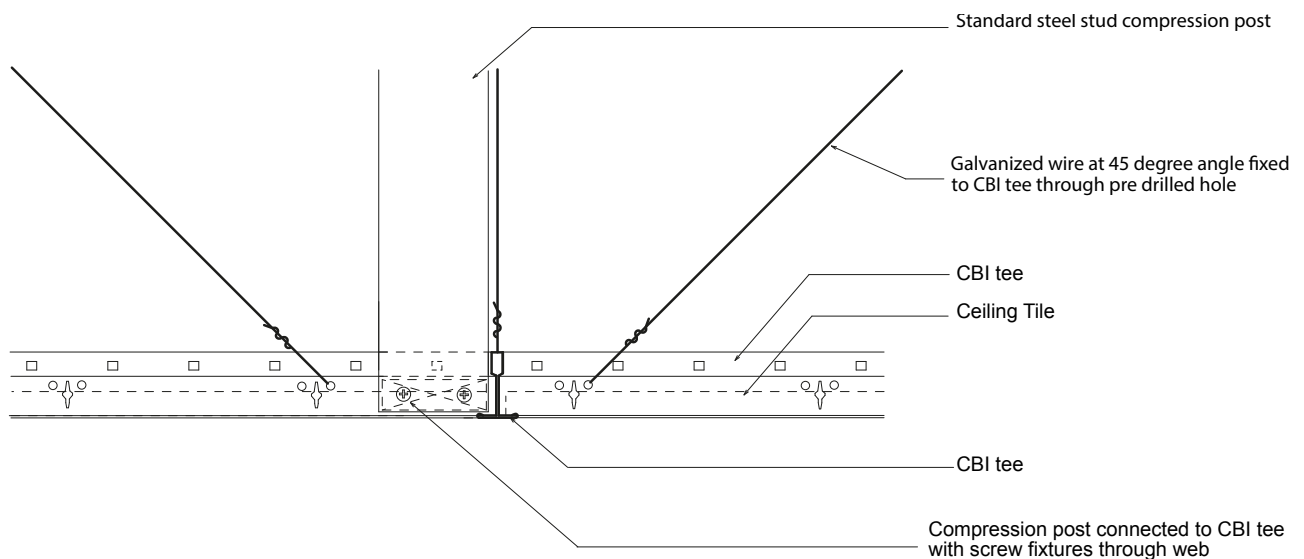

Wire Bracing Detail

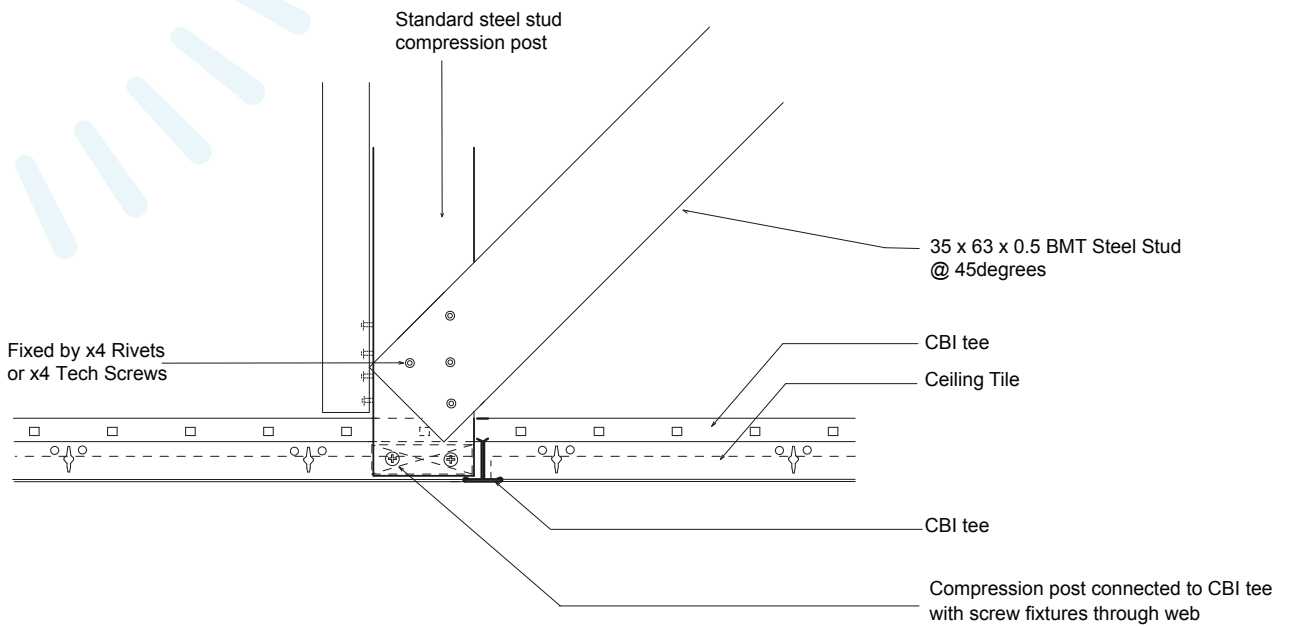

Stud Bracing detail

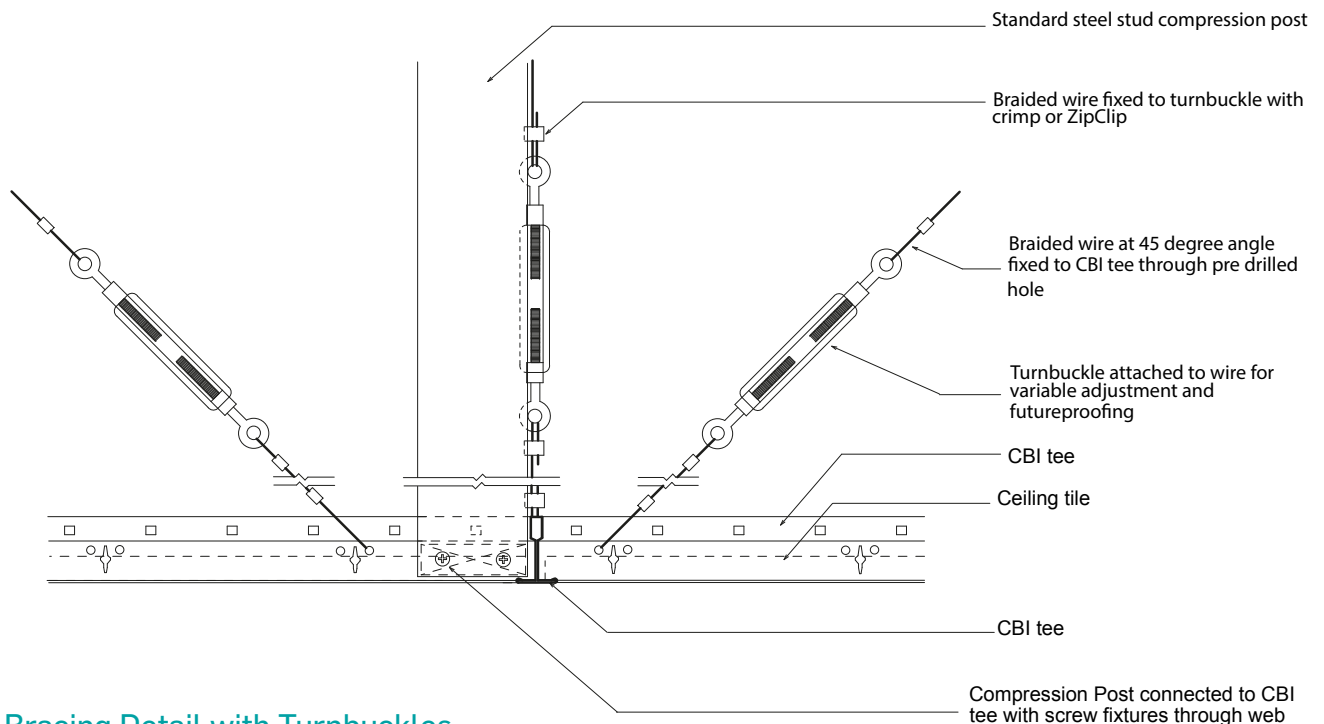

Bracing Detail with Turnbuckles

Adding turnbuckles to the tension wires future-proofs the bracing if there is ever large seismic activity. This allows the building maintainer to tighten the compression wires to maintain structural integrity for the next shake. This is to compensate for slipping in the wire connections, rather than for stretching of the wire.

Cross Nogging

Cross Nogging is a common practise in the ceiling industry. This method rotates the orientation of the grid in order to allow the long edge of the ceiling tiles to run in the same directions as the purlins. However, cross nogging is very detrimental to the strength of the grid. It should be avoided at all costs and will not work with the T & R Seismic System.

Cross Nogging

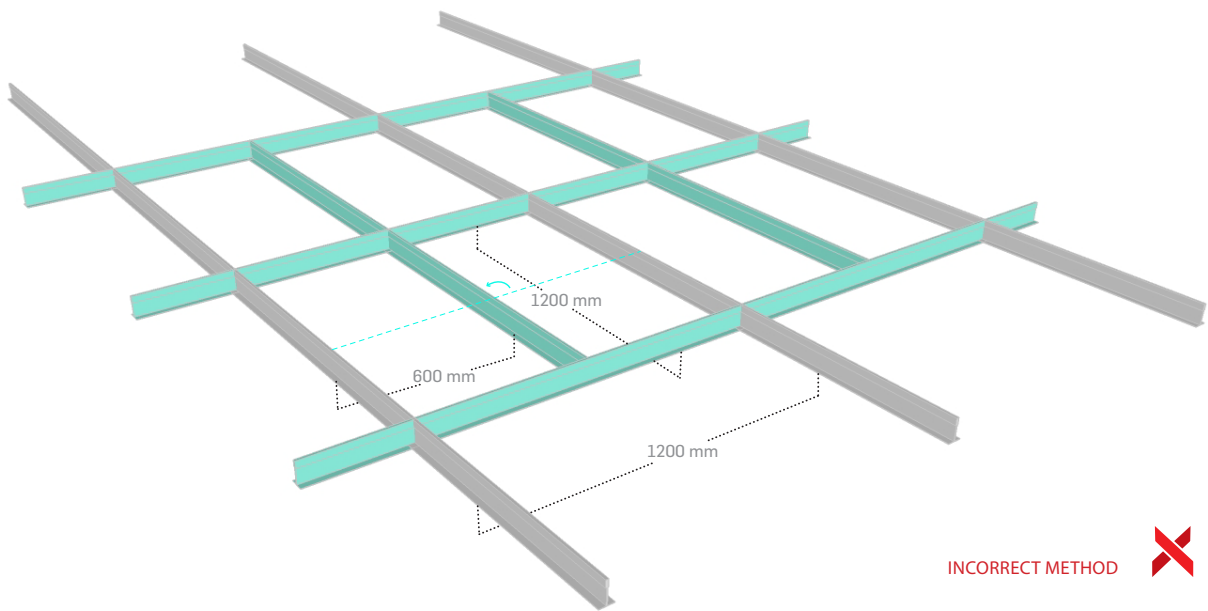

Correct Nogging

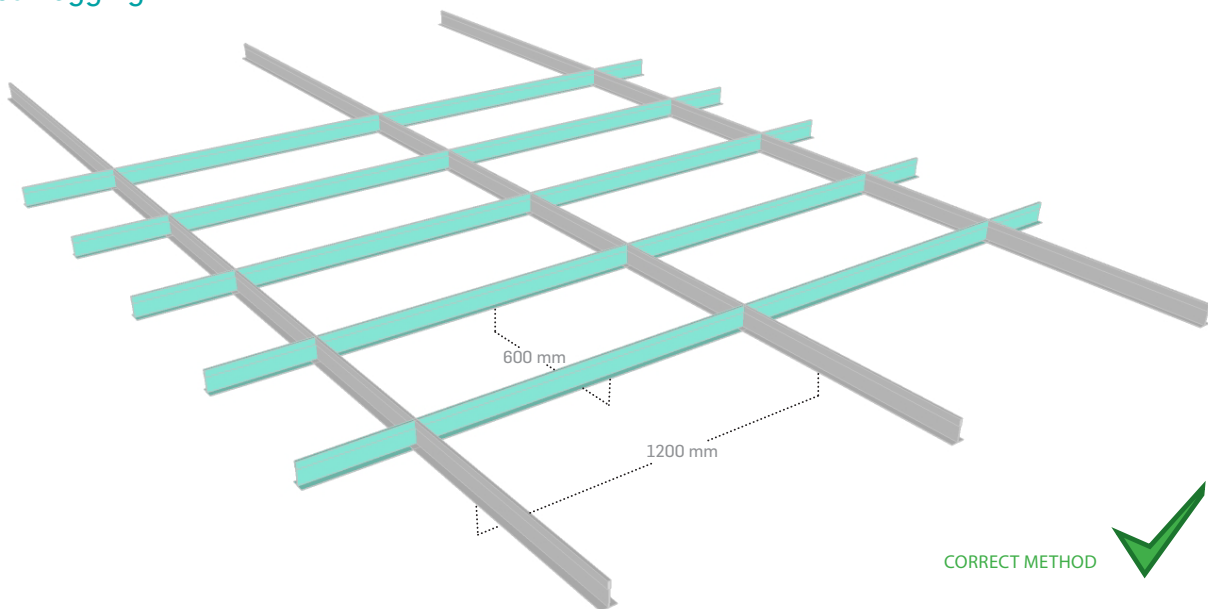

Seismic Joints

ASCE 7-10 - Minimum Design Loads for Buildings and other Structures specifies that "ceilings larger the 2500 ft² (232 m²) shall be broken up into smaller areas by seismic joints unless sufficient clearance is provided to accommodate lateral displacement". Since the T & R Seismic Design philosophy treats ceilings as units for seismic purposes and bracing prevents relative motion between sections anyway, the clearance for movement around the ceiling edges is sufficient to accommodate lateral displacement in most cases.

There are designs where Seismic Joints are required: namely, where a seismic joint exists in the structure above the suspended ceiling.

They can also be used where the ceiling length and width are **less than twice** the maximum length for Tee spans for the edge fixing method. The seismic joint effectively creates a floating edge which means that the four sections require no back bracing, whereas the complete ceiling with floating edges would.

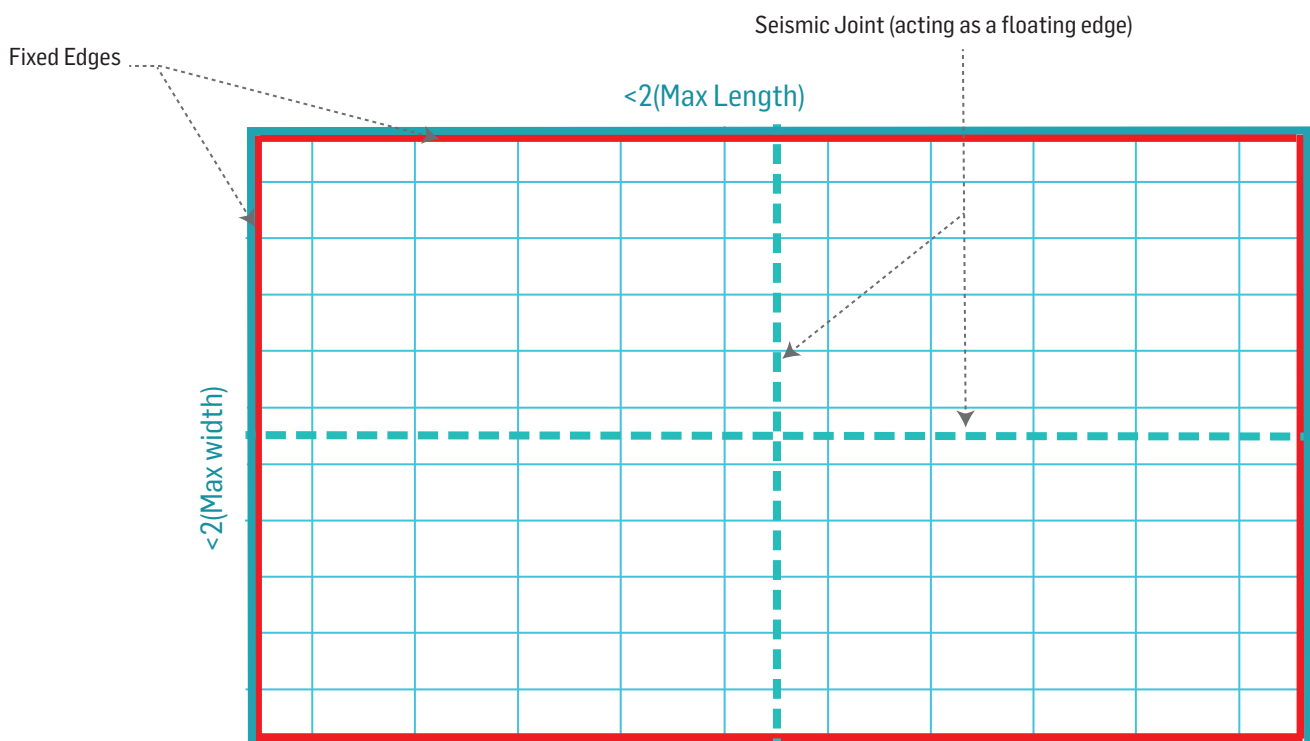



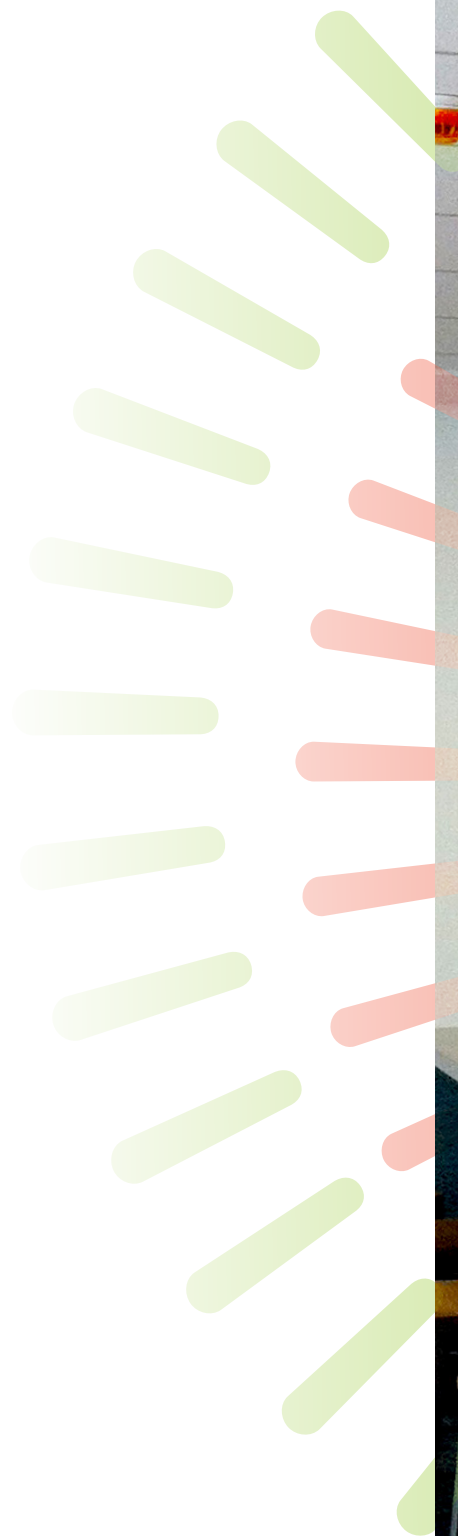



Detail Drawings

Fixed Edge

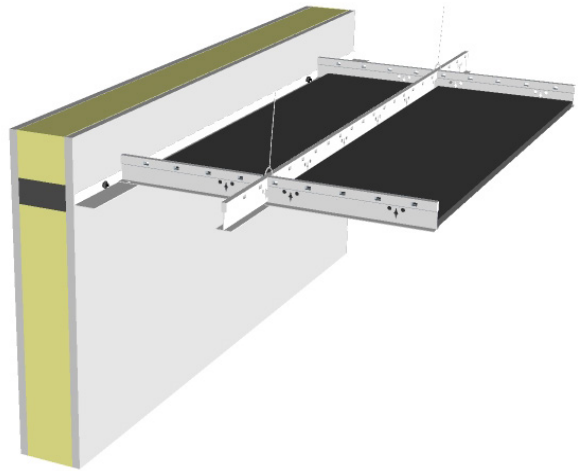

Fixed Edge Plan

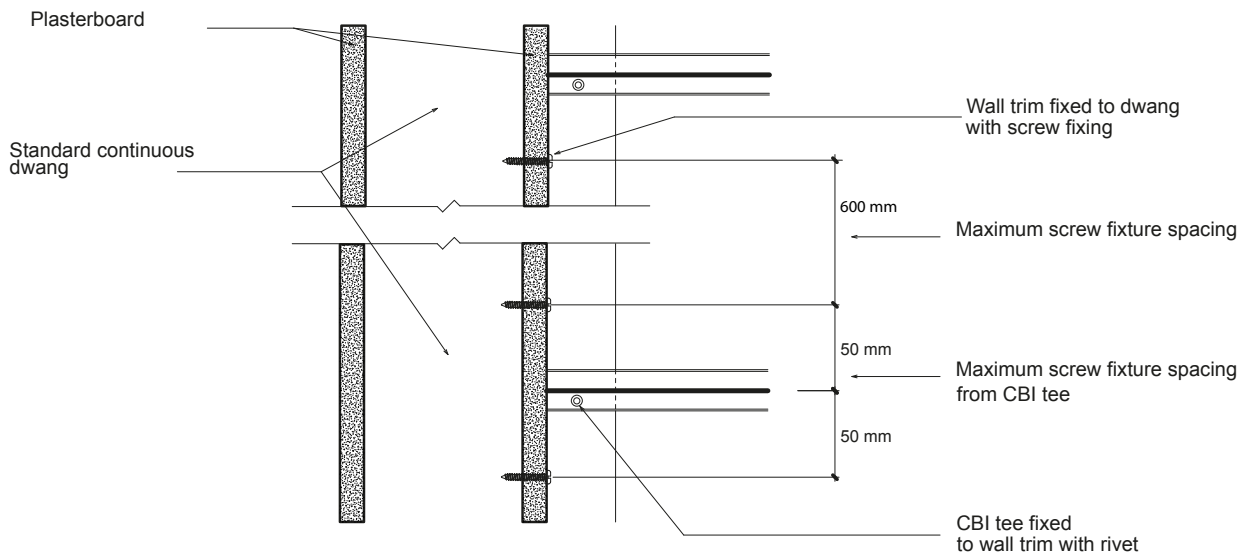

Fixed Edge Section

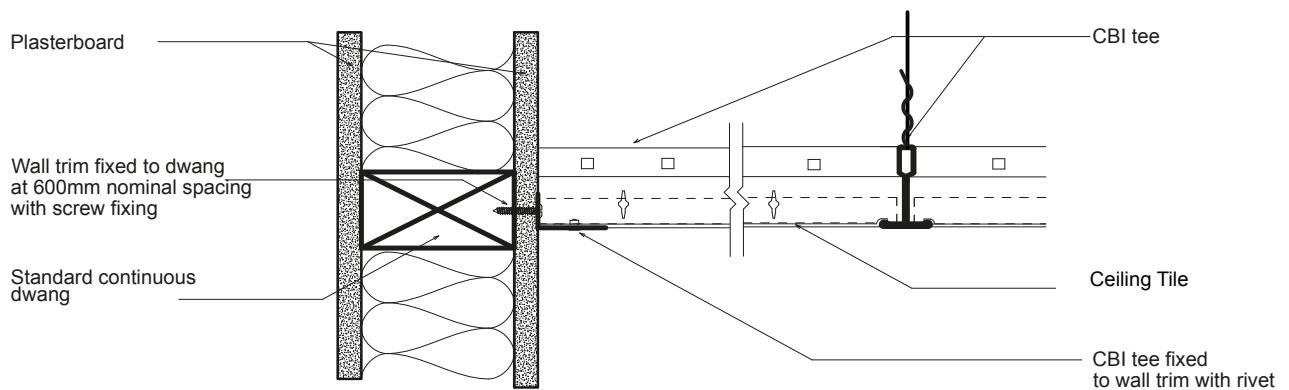

Floating Edge

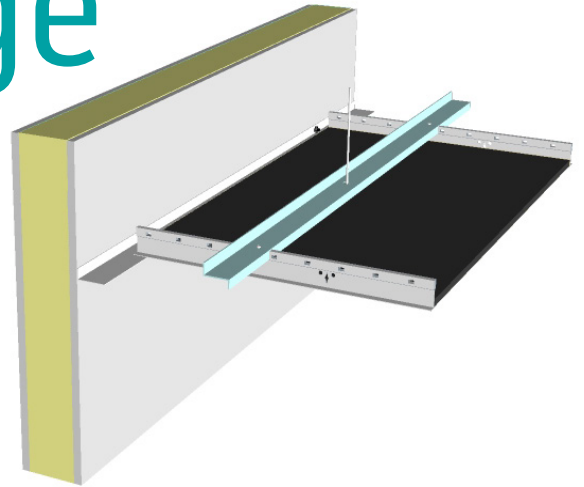

Floating Edge Plan

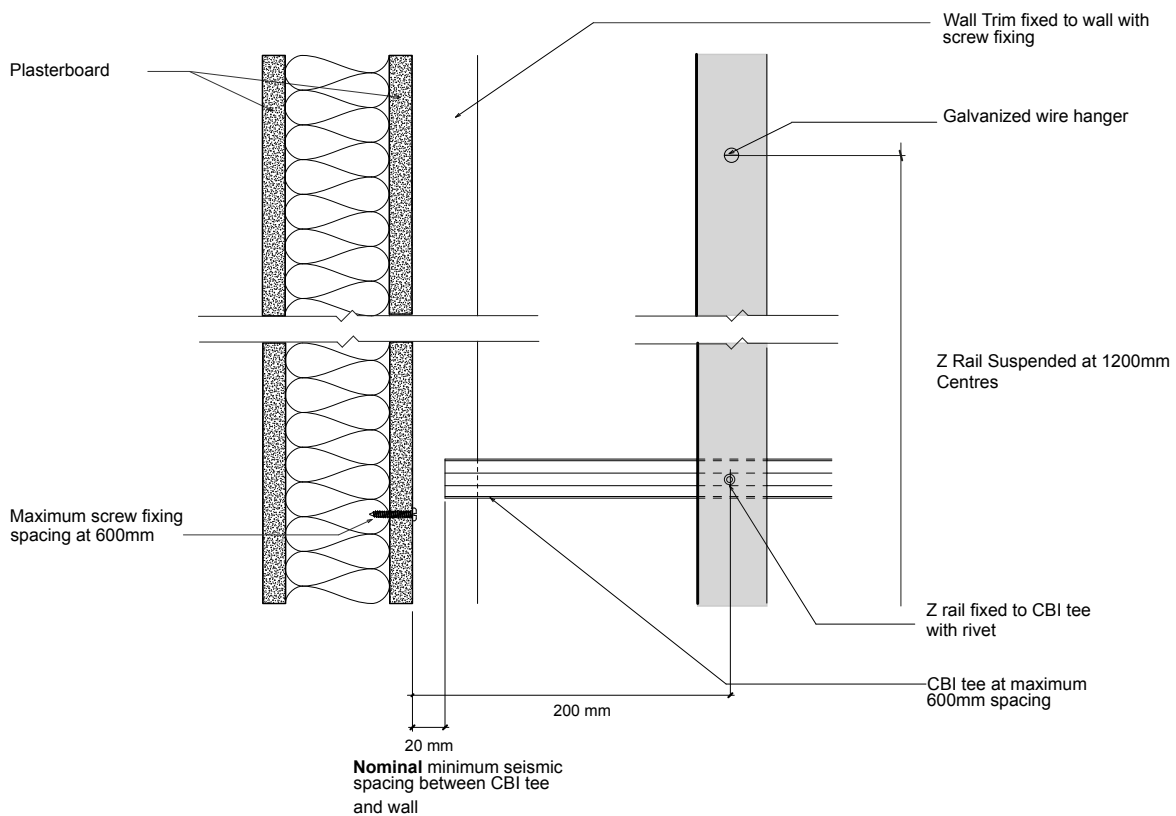

T & R Seismic System specifies a nominal 20mm Seismic Space between termination of tee and the wall.
The expected deflection at ceiling height = the seismic spacing required

This should be discussed with a structural engineer.

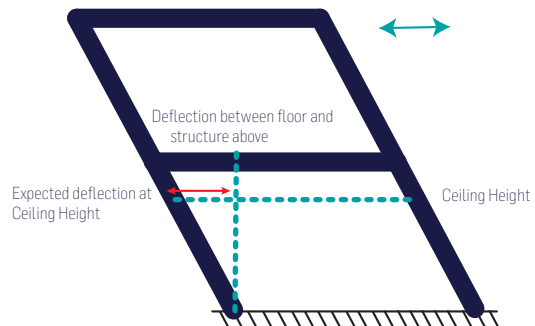

The deflection between the FFL and structural floor above ceiling in section.

Floating Edge Section

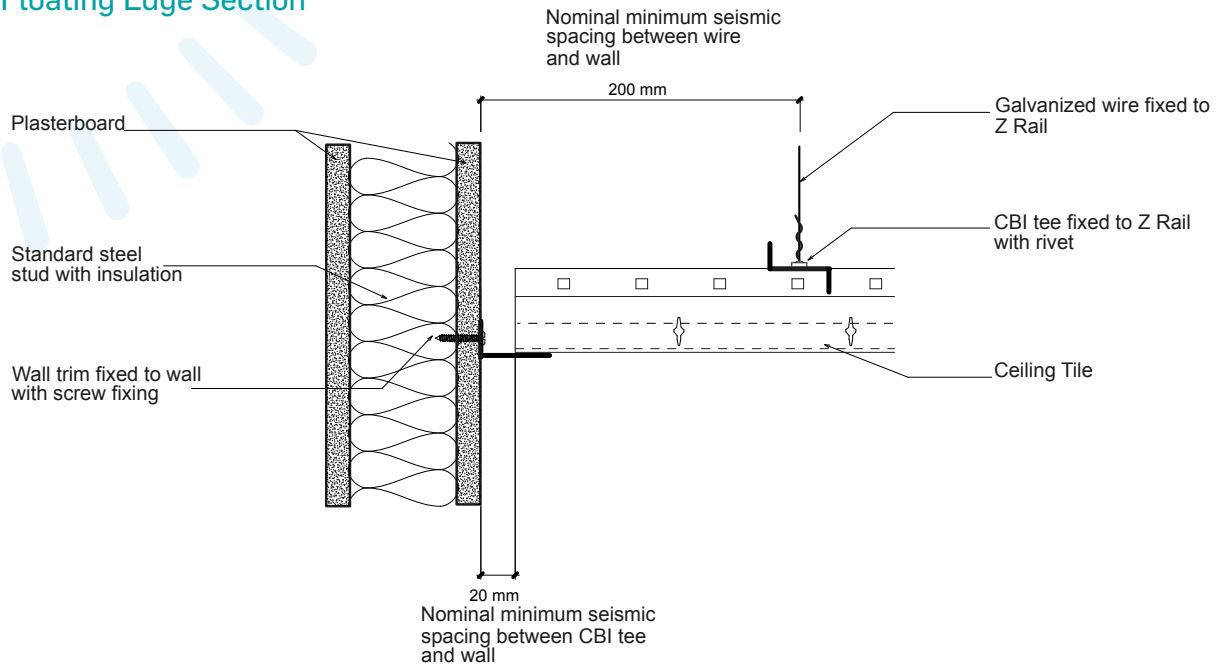

Alternative Floating Edge Section

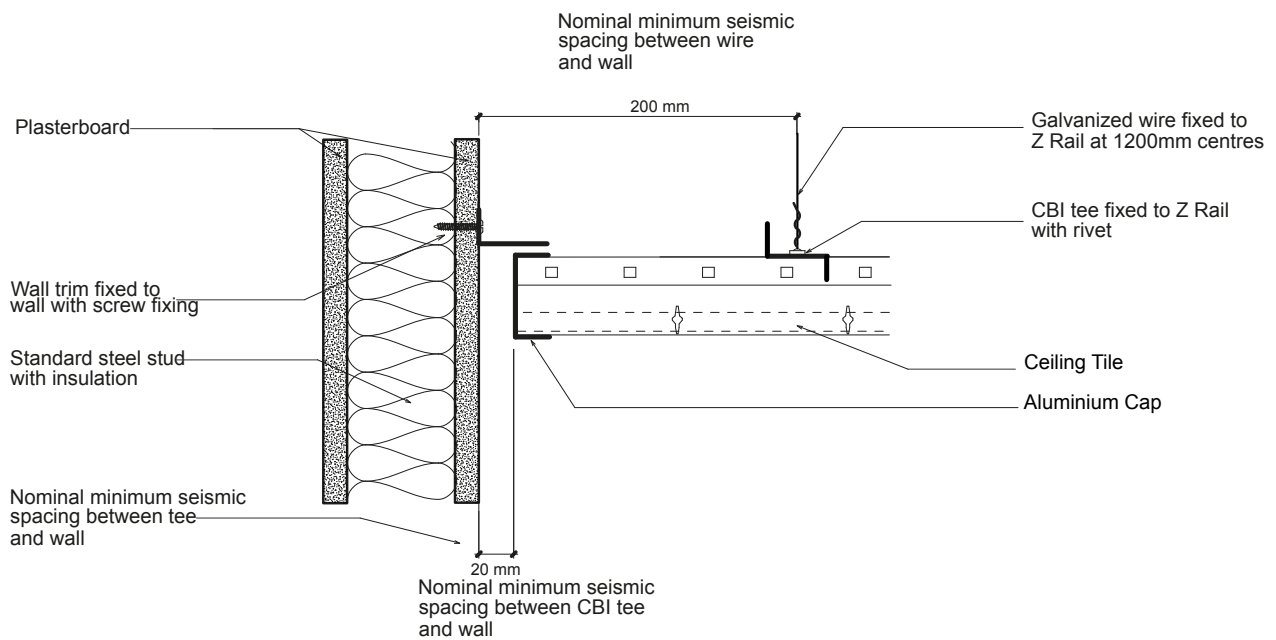

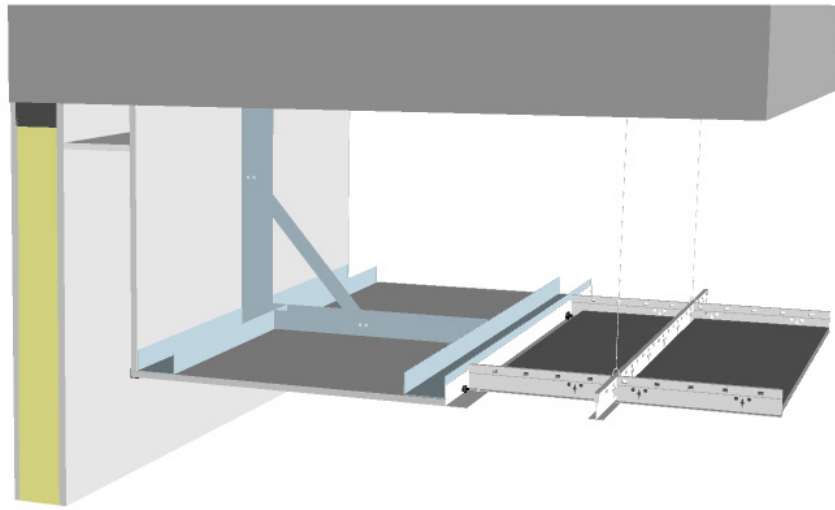

Floating Bulkhead Detail

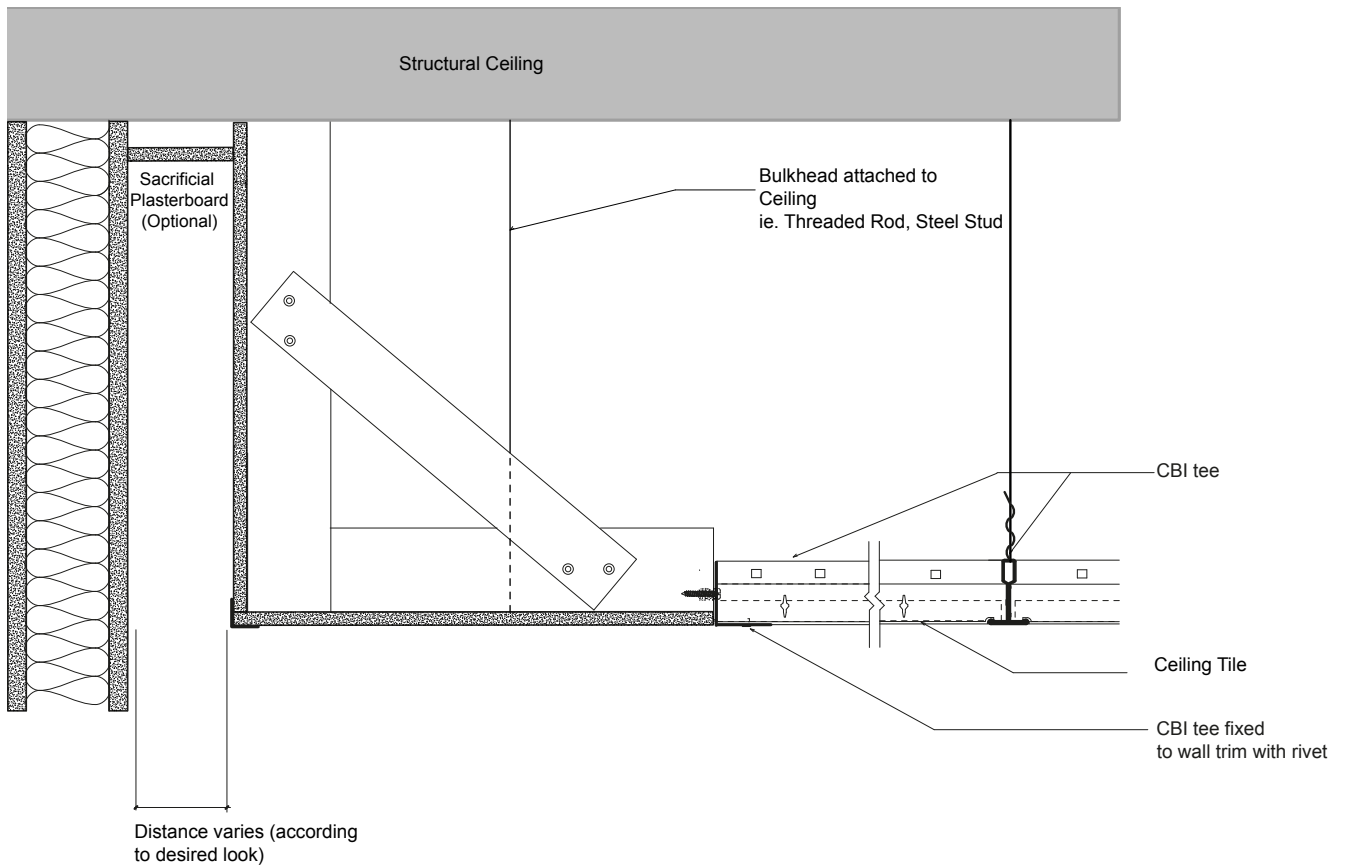

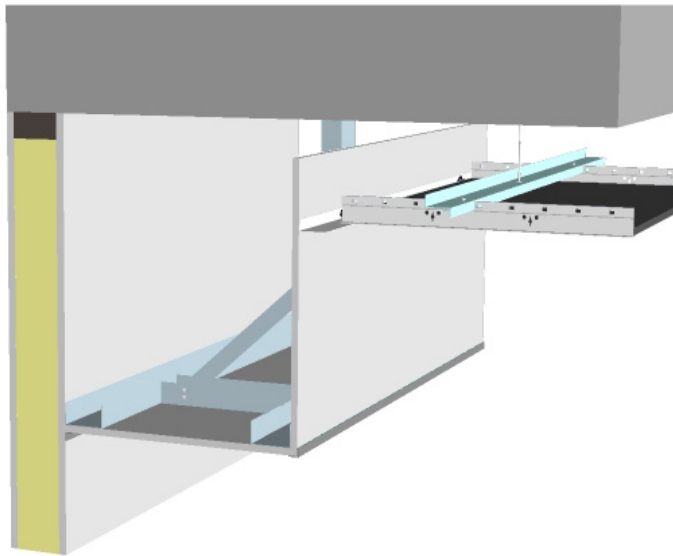

Bulk Head Floating Detail

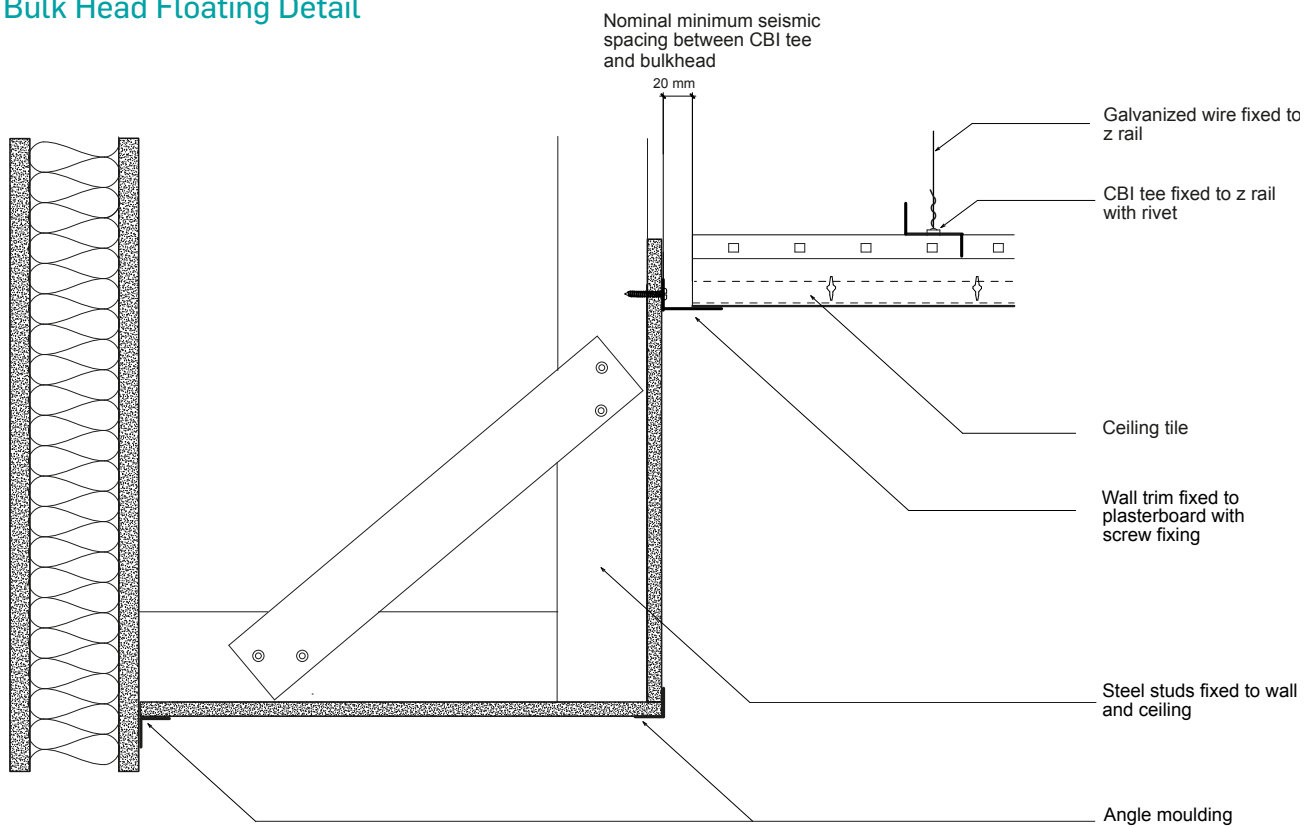

TRACKLOK Wall Partitioning

TRACKLOK Wall Partitioning Seismic Bracing

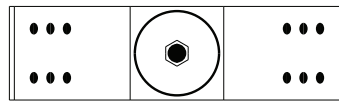
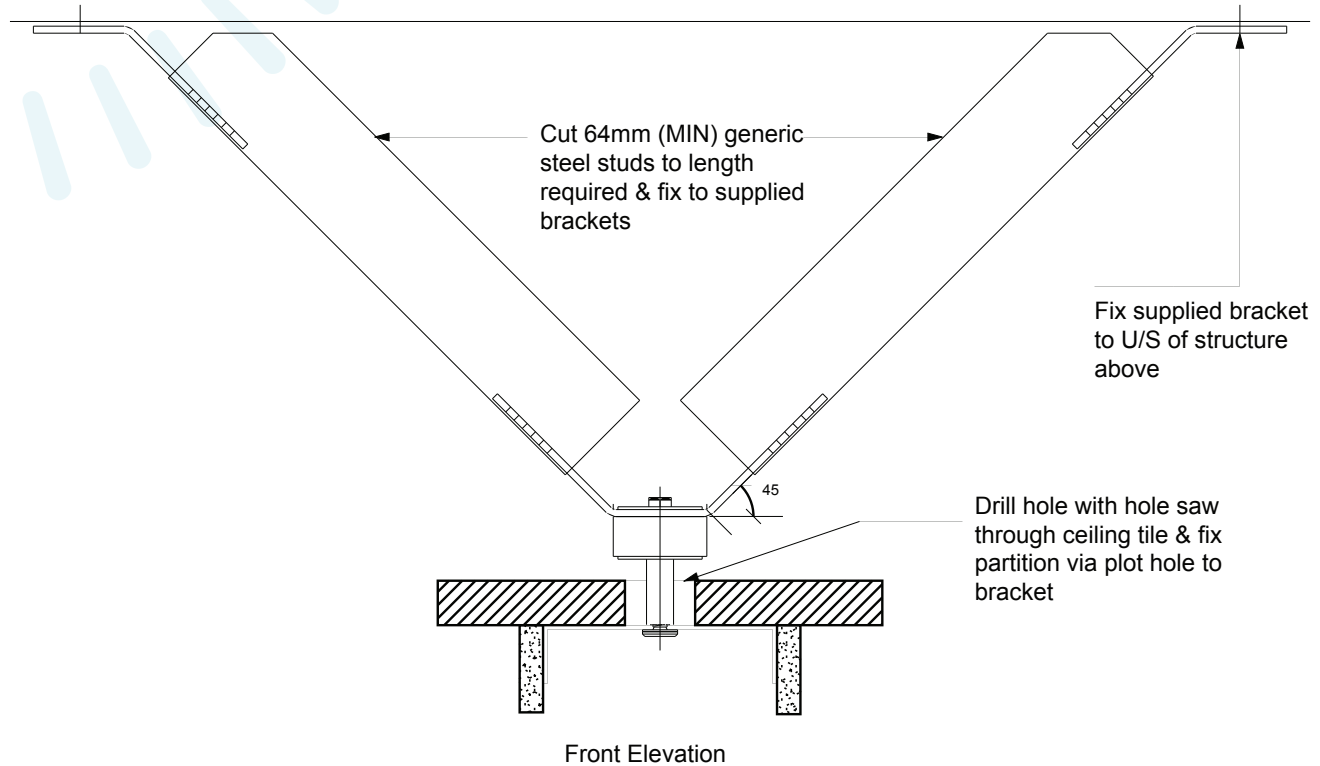

Plan View

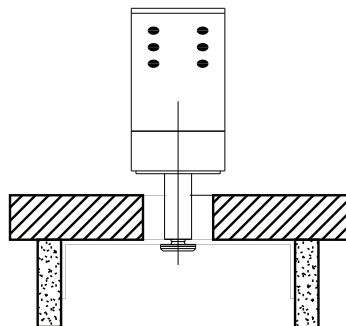

Side Elevation





T & R Seismic Bracing Calculator

T & R Seismic Calculator

Recommended Use:

This generic seismic design guide can be used to approximate the seismic bracing requirements for a suspended ceiling. The guide is intended for use by installers or designers to determine bracing requirements, and is based on a range of conservative assumptions used to determine seismic loads. Assumptions and limitations are outlined below.

To simplify the calculations required, the use of this design guide is restricted to T&R Interiors Systems' CBI Two Way Suspended Ceiling Grid and the compression-post design of seismic brace shown in this guide.

This guide should be used for indicative seismic design and costing for ceiling bracing in buildings of importance level 3 or below.

Seismic Brace Design:

- For use with CBI grid
- Uses T&R batten and 3mm steel wire to brace ceiling grid to supporting structure
- Capacity of each brace depends on plenum depth and ceiling mass

Usage Notes

This guide allows a designer to calculate required bracing for suspended ceilings. The calculations are based on conservative assumptions. Reduced seismic bracing designs for individual sites may be possible if a suitably qualified Chartered Professional Engineer carries out a site-specific design. This guide should not be used as a calculation template for a PS-1; specific seismic design should be carried out for these cases.

This guide has been prepared by BVT Engineering Professional Services for T&R Interior Systems with the usual care and thoroughness of the consulting profession. Interpretation and application of this guide is outside the control of BVT and therefore is the users' responsibility. This guide does not constitute a producer statement or engineer's certification, and is not for use with trafficable ceilings or ceilings which support partition walls or any other service load.

Allowance for relative motion between the ceiling and structure must be provided by floating edges. If the perimeter bracing method is used then two perpendicular edges must be fixed with the remaining two floating. If back bracing to the upper structure is used, then all edges must be floating. Floating edges must also be provided around rigid or separately braced items that pass through the ceiling. The amount of clearance should be checked by an engineer on a case-by-case basis.

Consult a structural engineer for the expected earthquake deflections of the structure.

Online Seismic Calculator available online
Visit www.tr-interiorsystems.co.nz

The following Assumptions have been made in developing this guide. Installers should ensure that the assumptions are accurate for the specific project being carried out. If projects fall outside the following scope, an engineer should be engaged.

- The installation is located within New Zealand.
- Building height must not exceed 40m.
- This design guide is for building of importances levels 2 and 3 only.
- The design Working Life of the ceiling is 50 years.
- The ceiling has a part period less than 0.75s.
- The building has a period of 5s or greater.
- The ceiling is assumed to be Part Category 3 if the height above floor level is greater than or equal to 3m and is assumed to be Part Category 7 if it is less than 3m above floor level.
- For Category 7 ceilings, seismic bracing calculations have been based on resisting seismic forces resulting from a 1-in-25 year event.
- The ceiling has a ductility of 2 as suggested by the supplement to NZS 1170.5
- Only horizontal forces have been considered in this guide.
- The walls or partitions must be of suitable design to allow for fixing (continuously noggled at ceiling height, Independently braced for the additional ceiling load).
- Partitions are not attached to the suspended ceiling
- Design applied to 24mm CBI grid only.
- Maximum Tee spacing of 1200mm in any direction.
- The ceiling installation is non-trafficable.
- The ceiling grid and tile are to be installed in accordance with T&R interiors and CBI specifications.
- Individual ceiling components must not weigh for than 10kg.
- All other components installed in conjunction with the ceiling have clearance distances as required by NZS 4219
- There must be no reason why ceiling movement or damage would cause an unusually high level of hazard or damage.

[Step One]

Calculate the total seismic weight based on the ceiling and service weights.

[Step Two]

Calculate seismic force based on seismic zone, height above floor level, height above ground level, and building importance level.

[Step Three]

Calculate the maximum main and cross tee lengths based on seismic force and tee capacity.

If maximum length is too small, try breaking ceiling up into smaller sections, or proceed to step six for back bracing design.

[Step Four] [If a full floating ceiling is desired, proceed to step six.]

Calculate the maximum tee length based on perimeter connection

If maximum length is too small, try adding seismic gaps, and breaking ceiling up into smaller sections or proceed to step six for back bracing design.

[Step Five]

Calculate the maximum tee length based on wall capacity, or the line load required for design of wall. If line load is too great for walls, the ceiling will need to be back braced, proceed to step six.

[Step Six]

Calculate maximum area per brace based on seismic force, brace type and plenum height.

[Step Seven]

Specify brace layout, spacing and number of braces required.

[Step Eight]

Specify components such as: Seismic joints, perimeter connection, upper structure connection, any additional steel work required.

[Step Nine]

Fill out summary sheet.

Step One - Seismic Weight

Enter the corresponding values in the column on the right and sum all the component weights to get a total seismic weight. This value will be used in the following steps this worksheet.

Table 1.1 - Seismic weight (kg/m²)

Grid Mass (see table 1.2)		
Tile Mass (refer to tile specifications)		
Services (min 3 kg/m ²)	: Luminaires	
	: Insulation	
	: Other	
Total		

Table 1.2 - Grid Weight (kg/m²)

Layout		Grid Weight (kg/m)
MT @1200	CT @ 600	1.1
	CT @ 1200	0.7
MT @ 1200	CT @ 1200 Cross Nog @ 1200	1.0
	CT @ 1200	0.9
MT @ 600	CT @ 1200	0.9
	CT @ 600	1.0

Step Two - Seismic Actions

Select the corresponding factors from Table 2.1 based on the ceiling location and Figure 1.

Select the corresponding factor from Table 2.2 based on the ceiling heights above floor level.

Select the corresponding factor from Table 2.3 based on the ceiling height above ground level.

Select the corresponding factor from Table 2.4 based on the listed conditions.

Table 2.1 - Zone Factor

Zone	Factor
1	0.37
2	0.37
3	0.51
4	0.44
5	0.67
6	0.88

Table 2.2 - Part Risk Factor

Height of ceiling above floor (m)	Factor
0-3	1
3+	0.9

Table 2.3 - Floor Height Factor

Height of ceiling above ground level (m)	Factor
less than 3	1.5
3 - 6	2
6 - 12	2.5
12- 20	3

Table 2.4 - Return Rate Factor

ApoE		Factor
For ceiling heights less than 3m	For ceilings not located in zone 4	0.25
	For ceilings located in zone 4	0.5
For ceiling heights greater than 3m	Building importance level 2	1.72*
	Building importance level 3	2.236*

*Values can be reduced by a factor of 1.72 if location is not given in table 3.6 of NZS 1170.5

Figure 1. NZ Zones

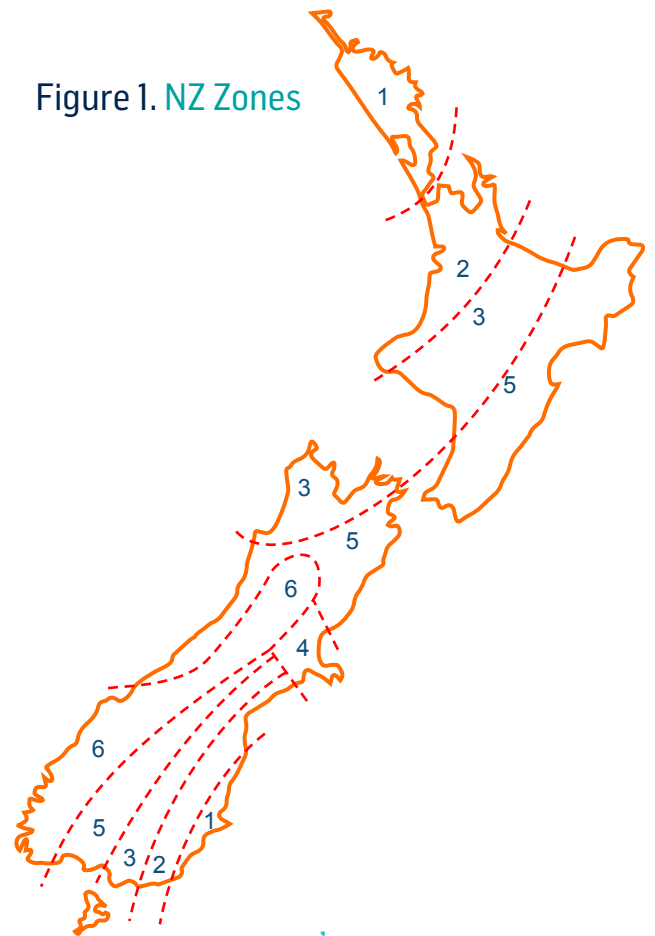

Insert the seismic weight from Step One and ensure the values from Tables 1-4 have been inserted as well. Multiply the seismic force by the factors found from Tables 1-4 to get a value for seismic force (kgf/m²). This value will be used in the following steps.

Table 2.1	x	Table 2.2	x	Table 2.3	x	Table 2.4	x	Seismic Weight	=	Seismic Force

Step Three - Tee Capacity

Physical testing has given an average tee capacity (**limited by connections between tees**). The following step calculates the minimum allowing tee length for the cross tees and main tees. This will be used in both the perimeter bracing method and the back bracing method.

Insert the seismic force calculated in Step Two and select the appropriate tee spacing. Complete the given operations to calculate the maximum allowing tee length.

If maximum length is too small, try adding seismic gaps and breaking ceiling up into smaller sections or proceed to Step Six for back bracing design.

Table 3.1 - Tee Lengths (based on connection capacity)

Cross Tee

Cap. CT(kg)	/	Seismic Force	/	CT spacing	=	Lct (m)
63				1.2 or 0.6		

Main Tee

Cap. MT(kg)	/	Seismic Force	/	MT spacing	=	Lmt (m)
84				1.2 or 0.6		

Step Four - Connection Capacity

The tee length is also limited by the connection to the wall (only for the perimeter fixing method). Enter the seismic force from Step Two and complete the given operations to calculate the minimum tee length for the spacing options.

If maximum length is too small, try adding seismic gaps and breaking ceiling up into smaller sections or proceed to Step Six for back bracing design.

Table 4.1 - Tee Lengths (based on perimeter fixing)

Cap. Fixing (kg)		Seismic Force		Tee spacing		Lt (m)
Capacity (table 4.2)	/		/	1.2	=	
				0.6		

Table 4.2 - Fixing Capacities

Fixing Type (kg)	Capacity
1 Rivet	70
2 Rivet	140

Step Five - Partition Capacity

For the perimeter bracing method, it is important to check the capacity of the walls that the ceiling is fixed to. Insert the seismic force from Step Two and the governing tee length from Step Four in the table below to calculate the line load in which the wall will need to resist.

All wall and partitions in which the ceiling is fixed must have a continuous dwang along at ceiling height.

Table 5.1 - Line load based on limiting tee length

Seismic Force		Max (CT, MT)		Line Load
	x		=	

If the wall does not have sufficient capacity, then the ceiling can be broken up into smaller sections based on the new limiting tee length calculated below. Insert the known wall capacity and seismic force as calculated in Step Two to calculate the new governing tee length based on the wall capacity

If the new governing tee length is too short and the ceiling cannot be broken into smaller sections, proceed to Step Six for back bracing design.

Table 5.2 - Tee lengths based on allowable wall load

Cap. Wall (kg/m)		Seismic Force		Tee space		Lmt (m)
	/		/	1.2	=	
				0.6		

Insert the governing tee length (minimum from Tables 3.1, 4.1, 5.1 and 5.2)

Table 5.3 - Governing tee length

Governing tee length for perimeter fixing (m)	Lct (max)	
	Lmt (max)	

Step Six - Back brace selection

Calculate the maximum area of ceiling that each brace can support based on seismic force from Step Two, desired brace type and plenum height.

Brace Capacity (kg)		/	Seismic Force	=	Area per brace
Plenum (m)					
	Brace Type				

Table 6.1a - Bracing Capacity (kg)

Plenum (m)	Brace Type	
	A	B
0.25	225	290
0.5	225	260
0.75	225	230
1	225	200
1.25	225	170
1.5	225	140
1.75	225	120
2	225	100
2.25	190	90
2.5	170	75
2.75	150	65
3	135	60

6.1b - Seismic Force / = 6.1c - Area per Brace

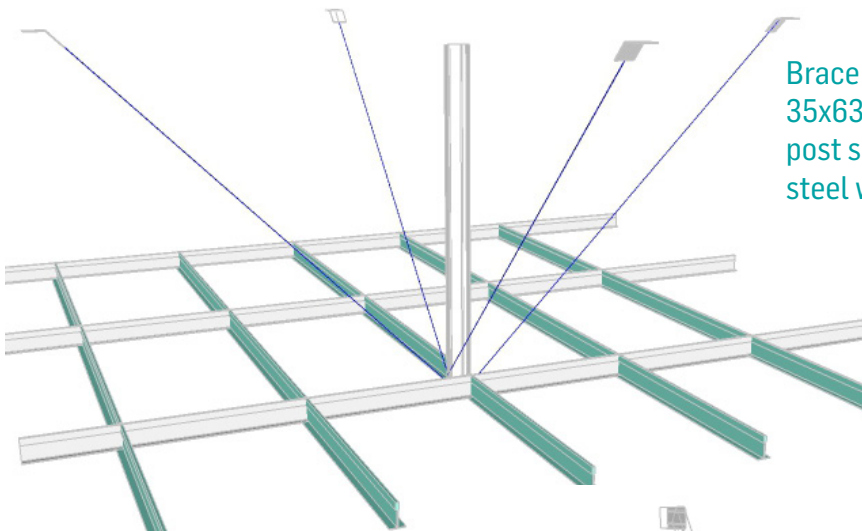





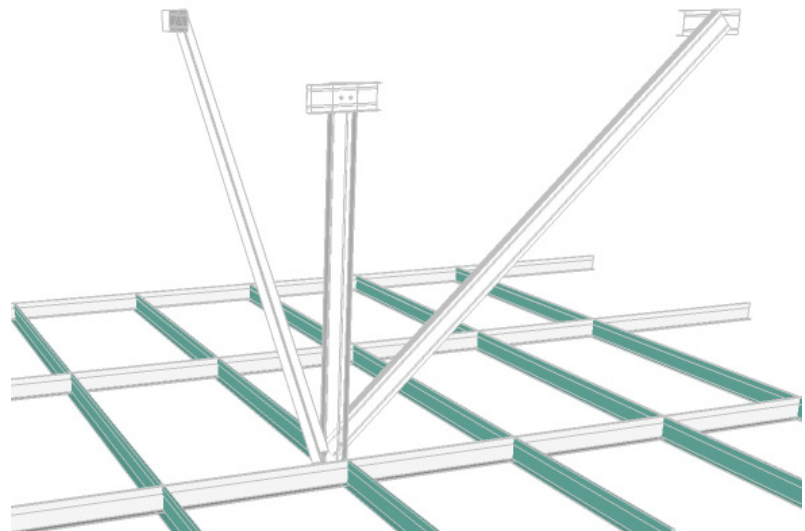

Brace Type A is constructed from a 35x63x0.5 BMT steel stud compression post supported by four 2.5mm galvanised steel wires at 45degrees.

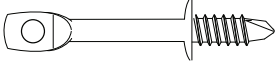
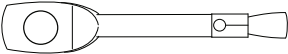
Brace Type B is constructed from a 35 x 63 x 0.5 BMT (Base Metal Thickness) steel stud compression post supported by Two 35 x 63 x 0.5 BMT steel studs at 45 degrees.

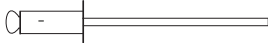

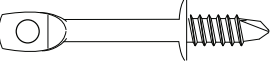
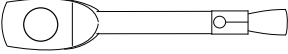
Brace Details - Connection Details

Connection	Fastener	
Wire to steel	1x 10g Tek Screw	
Wire to concrete	1x M6 Mechanical Anchor	
Wire to wood	1x 10g Wood Screw	
Post to grid	3x 4mm Rivets	
Post to bracket	3x 4mm Rivets	
Bracket to steel	3x 10g Tek Screws	
Bracket to concrete	2x M6 Mechanical Anchor	
Bracket to wood	2x 10g Wood Screw	



Step Seven - Back Brace Layout

Option 1.

When it is known that the ceiling acts as a diaphragm capable of transferring the load of the unbraced tees to the braced tees, then the braces can be simply spread evenly over the ceiling based on the maximum area per brace and the total area of the ceiling.

Whether or not the ceiling acts as a diaphragm depends on the ceiling tiles and grid work. This option should not be used without consulting an engineer on a site-specific basis.

Table 7.1 - Number of braces

Total Ceiling Area		Max area per brace (Table 6.1)		Minimum amount of braces required
	/		=	

Option 2.

This is a more conservative option and should be used if any uncertainty exists about the ceiling acting as a diaphragm. It is assumed that the ceiling can act as a diaphragm for a span of 2.4m (Y_1 and X_1). Consequently, every second tee (at 1.2m spacing) or every fourth tee (at 0.6m spacing) must be braced at a minimum of one point along its length. The spacing of these braced tees (Y_1 and X_1) is determined by either the minimum allowable

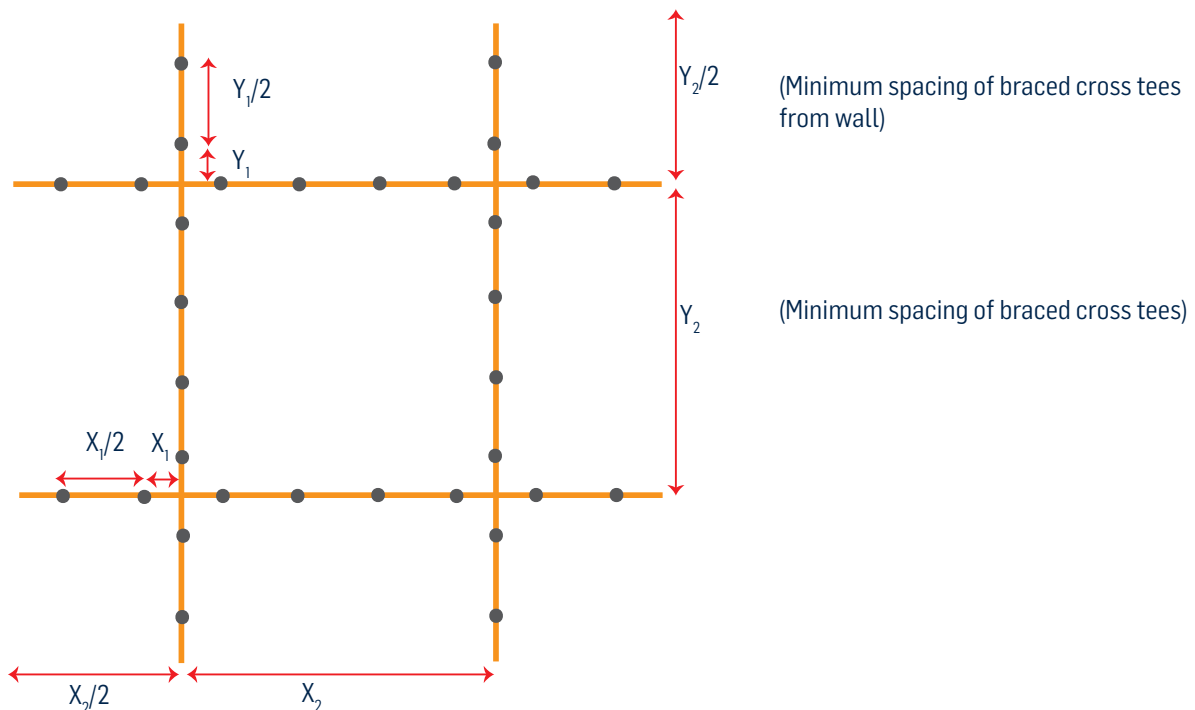

tee length or the maximum allowable area per brace.

Area per brace (A_b)	/	X_1	=	Y_2
		2.4		

Area per brace (A_b)	/	Y_1	=	X_2
		2.4		

The minimum allowable tee length calculated in Table 3.1 must be greater than Y_2 and X_2 or it becomes the limiting value for braced tee spacing.

Seismic Calculator

1. Seismic weight (kg/m²)

Grid Mass (see table 1.2)	
Tile Mass (refer to tile specifications)	
Services (min 3 kg/m ²)	<ul style="list-style-type: none"> ⋮ Luminaires ⋮ Insulation ⋮ Other
Total	

2. Seismic Force (kgf/m²)

Select the corresponding factors from Tables 2.1. - 2.4

Table 2.1	x	Table 2.2	x	Table 2.3	x	Table 2.4	x	Seismic Weight	=	Seismic Force

3. Tee Lengths (based on connection capacity)

Cap. CT(kg)	/	Seismic Force	/	CT spacing	=	Lct (m)
63				1.2 or 0.6		

Cap. MT(kg)	/	Seismic Force	/	MT spacing	=	Lmt (m)
84				1.2 or 0.6		

If maximum length is too small, try adding seismic gaps and breaking ceiling up into smaller sections or proceed to Step 6 for back bracing design.

4. Tee Lengths (based on perimeter fixing)

Cap. Fixing (kg)	/	Seismic Force	/	Tee spacing	=	Lt (m)
Capacity (table 4.2)				1.2		
				0.6		

If maximum length is too small, try adding seismic gaps and breaking ceiling up into smaller sections or proceed to Step Six for back bracing design.

For the perimeter bracing method, it is important to check the capacity of the walls that the ceiling is fixed to.

5. Line load based on limiting tee length

Seismic Force	x	Max (CT, MT)	=	Line Load

- All wall and partitions in which the ceiling is fixed must have a continuous dwang along at ceiling height.
- If the new governing tee length is too short and the ceiling cannot be broken into smaller sections, proceed to Step Six for back bracing design.
- If the wall does not have sufficient capacity, then the ceiling can be broken up into smaller sections based on the new limiting tee length calculated below.

Tee lengths based on allowable wall load

Cap. Wall (kg/m)	/	Seismic Force	/	Tee space	=	Lmt (m)
				1.2		
				0.6		

Governing tee length

Insert the governing tee length (minimum from Tables 3.1, 4.1, 5.1 and 5.2)

Governing tee length for perimeter fixing (m)	:	Lct (max)	
	:	Lmt (max)	

OR

6. Brace Capacity

Brace Capacity (kg)	/	Seismic Force	=	Area per brace
Plenum (m) : <input type="text"/> Brace Type : <input type="text"/>				

Select Brace Plenum and Type from Table 6

7. Number of Braces

Total Ceiling Area	/	Max area per brace (Table 6.1)	=	Minimum amount of braces required

OR

Area per brace (Ab)	/	X ₁	=	Y ₂
		2.4		

Area per brace (Ab)	/	Y ₁	=	X ₂
		2.4		



Current research shows a significant need to reduce the amount of hardcopy resources in favour of eco friendly online recourses for both architects and designers. T & R Interior Systems recognises this need and are happy to be able to offer the following resource options:



www.tr-interiorsystems.co.nz and www.acoustic-solutions.co.nz

Our online resources include datasheets, technical information, DWG files, Revit files, Brochures and industry specific eBooks. Our product range includes suspended ceiling and interior wall systems, steel stud, Eclipse Office Partitioning Suite, acoustic panels and thermal and acoustic insulation.

masterspec

www.masterspec.co.nz

Masterspec is the leading specification systems in New Zealand's construction industry used by over 1200 design practices. Available on two operating systems. Masterspec provides detailed specification resources that can easily be modified to suit any project. Masterspec delivers Standard, Structural and Civil Services, Landscapes, Basic Interiors and Minor Residential, accepted as the most efficient and reliable industry-standard solution available for design professionals. Making it easy to specify T & R products for your next project.



www.eboss.co.nz

EBOSS, the online technical library for the building and construction industries. Designed by design professionals for design professionals. Our goal is to provide you with the information you require, when you need it and in the format that best suits your needs. EBOSS has the complete range of T & R Interior Systems suspended ceiling tiles, acoustic sound panels, aluminium partition suites and steel framing available with technical information.

creating quality ambient spaces



INT&RIOR SYSTEMS

Wellington Head Office
12 Glover St., Ngauranga
Wellington 6035
PO Box 38533
Wellington Mail Centre 5045
/t/ 04 499 5915
/f/ 04 499 5916

Auckland
19 - 21 Fairfax Ave,
Penrose, Auckland 1061
PO Box 112360,
Penrose, Auckland 1642
/t/ 09 571 0395
/f/ 09 571 0376

Christchurch
69 Disraeli St., Addington
Christchurch 8023
PO Box 7197
Christchurch 8240
/t/ 03 366 2507
/f/ 03 366 2508