

HENDERSON

HENDERSON PRODUCT CATALOGUE

Sliding and Folding Door Hardware



ASSA ABLOY

The global leader in
door opening solutions.

STRAIGHT SLIDING TOP HUNG DOOR SYSTEMS

Section Index and General Guide

Select system for your top hung application.	Residential	Commercial	Industrial	Max. Door	Product	Data Sheet
APPLICATION						
Residential						
For small cupboards and serving hatches	■			9kg	Slipper	B20
For wardrobes or large cupboards	■			27kg	Double Top Lite	B30
For sliding doors	■			30kg	Swift	B40
For sliding doors	■			30kg	Sprint	B50
For wardrobes or large cupboards	■			45kg	Single Top	B60
For wardrobes or large cupboards	■			45kg	Double Top	B70
For timber or metal sliding doors	■			55kg	Marathon 55 & 90	B80
For interior doors. To suit one or more doors	■			80kg	Rustic	B90
For timber or metal sliding doors	■			80kg	Sirocco	B100
Single line of doors for timber or metal sliding doors	■			100kg	Husky 50 & 100	B110
For timber or metal sliding doors	■	■		120kg	Universal Telescopic	B120
Simultaneous action kit for biparting doors	■			100kg	Husky SIM 100	B130
Commercial						
For interior doors. To suit one or more doors	■	■		100kg	Husky Low Headroom 100	B140
For interior and exterior doors. To suit one or more doors		■		120kg	Soltaire 120	B150
For interior doors. To suit one or more doors		■		120kg	Soltaire Low Headroom 120	B160
For interior doors. To suit one or more doors		■		120kg	Sienna	B170
For interior and exterior doors. To suit one or more doors		■		180kg	Soltaire 180	B180
For interior doors. To suit one or more doors		■		180kg	Soltaire Low Headroom 180	B190
For interior doors. To suit one or more doors		■		200kg	Pacer	B200
For interior and exterior doors. To suit one or more doors		■		250kg	Soltaire 250	B210
For interior doors. To suit one or more doors		■		250kg	Soltaire Low Headroom 250	B220
For interior doors. To suit one or more doors		■		500kg	Flexirol 500	B230
Industrial						
For timber or metal construction. Maximum door height – 3000mm			■	200kg	Straight Sliding 290	B240
For timber or metal construction. Maximum door height – 3000mm			■	450kg	Straight Sliding 301	B250
– 3600mm			■	700kg	Straight Sliding 305	B260
– 4000mm			■	2000kg	Straight Sliding 307	B270

SLIPPER

For sliding cupboard doors. Max 9kg.

APPLICATION

- For fitted bathroom and kitchen furniture of all kinds, such as serving hatches, cupboards and other items made from lightweight wood or chipboard
- For timber, timber framed or composite doors
- Silent – nylon slides on attractive aluminium track
- Easily top fixed
- Simple to remove doors for cleaning and decorating

DOOR SPECIFICATION

Track System	Slipper
For Individual Doors:	
Max Door Weight	9kg
Max Door Width	900mm
Door Thickness	16-30mm
Max Door Height	1800mm

STANDARD SETS AND PACK

Sets comprise of 2 top aluminium section tracks, 4 nylon sliders, 3 guides, safety stop, 2 flushpulls, all screws and fitting instructions.

Set No.	Opening width	Track length	Hardware for
HSS4	1200mm	1200mm	2 doors
HSS5	1500mm	1500mm	2 doors
HSS6	1800mm </td <td>1800mm</td> <td>2 doors</td>	1800mm	2 doors

Pack No.	Application
HSS1	Single door fittings pack

HARDWARE SPECIFICATION

Track	H130	Aluminium (900, 1200, 1500, 1800, 2400 & 3600mm lengths)
Slider	H131	White nylon <i>Sliders are molded with radiused sides for ease of installation and for a smooth sliding action.</i>
Door Stop	H28P	Rubber-buffered stop
Guides	H132	White nylon saw cut guide <i>Guides can be positioned on both sides of the door or slide in a sawcut in the centre line of the door.</i>
Accessories		
Flush Pull	H26P	

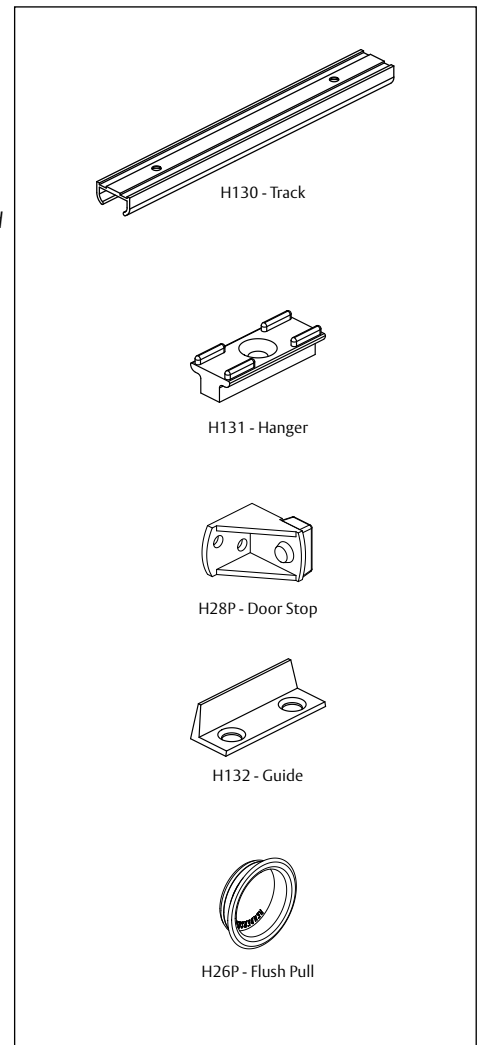

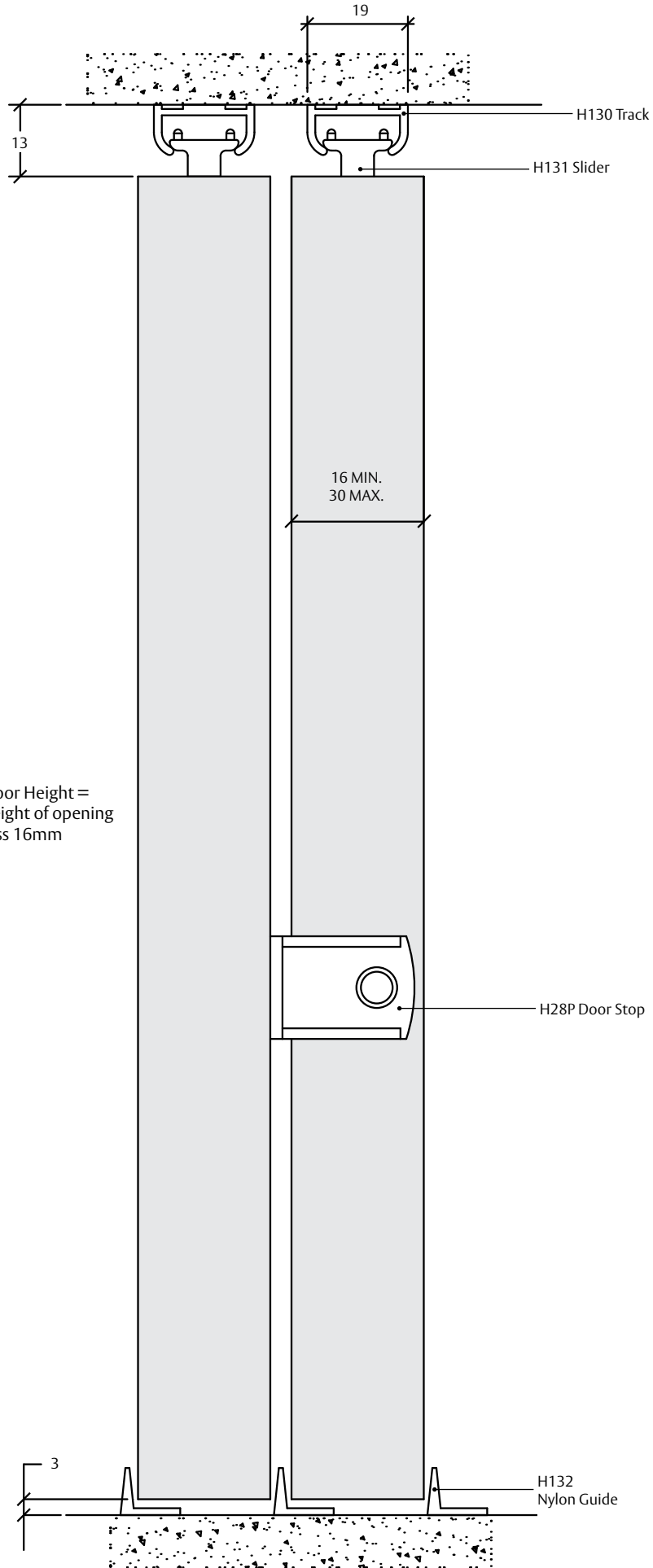

NOT TO SCALE

Door Height =
height of opening
less 16mm



HENDERSON

DOUBLE TOP LITE

For top hung sliding wardrobe doors. Max 27kg each.

APPLICATION

- For built-in furniture, i.e. wardrobes and cupboards in residential applications
- Easily adjusted door height
- Alternative guide channel systems available

DOOR SPECIFICATION

Track System Double Top Lite

For Individual Doors:

Max Door Weight 27kg
Door Thickness 16-38mm

Lightly framed timber doors or doors made from medium density fibreboard (MDF) must have provision for hangers to be screwed securely to the back face of the doors.

STANDARD SETS AND PACKS

Sets comprise top track, hangers, door stop(s), saw cut guide(s), all screws and fitting instructions.

Set No.	Opening width	Track length	Hardware for
HLW12	1200mm	1200mm	2 doors
HLW15	1500mm	1500mm	2 doors
HLW18	1800mm	1800mm	2 doors
HLW24	2400mm	2400mm	3 doors
Pack No.	Application		
HLW01	1 door pack		

HARDWARE SPECIFICATION

Track	HLWDA	Aluminium (1200, 1500, 1800, 2400 & 4800mm lengths)		
Hangers (2 per door)	HLW220	Outer offset hanger		
	HLW221	Inner offset hanger		
	HLW222	Reversible offset hanger		
Door Stop	H28P	Rubber-buffered stop		
Guides	H101N	Nylon saw cut guide		
Accessories	Single track	HLWA	Aluminium (1200, 1500, 1800, 2400 & 4800mm lengths)	
		Guides	H24/25	Adjustable nylon guide
		H106SL/94	Spring loaded guide (suits H81X channel & H94FM channel)	
H113/81X	Nylon guide (suits H81X channel)			
Channels	<i>For heavy duty applications or where more than 3 doors are required per opening</i>			
	H81X	Aluminium channel (1200, 1500, 1800, 2400 & 3600mm lengths)		
	H94FM	Aluminium channel (2000, 3000, 4000 & 6000mm lengths)		

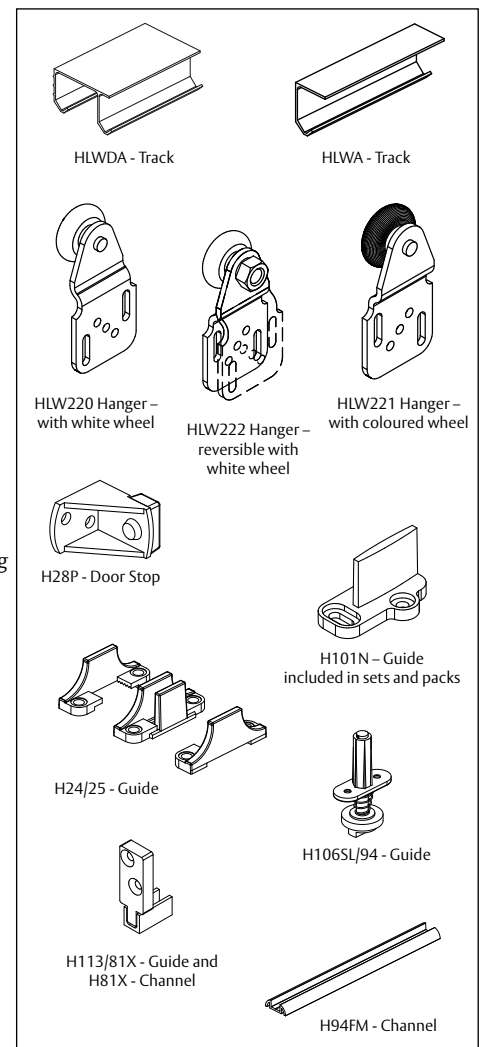

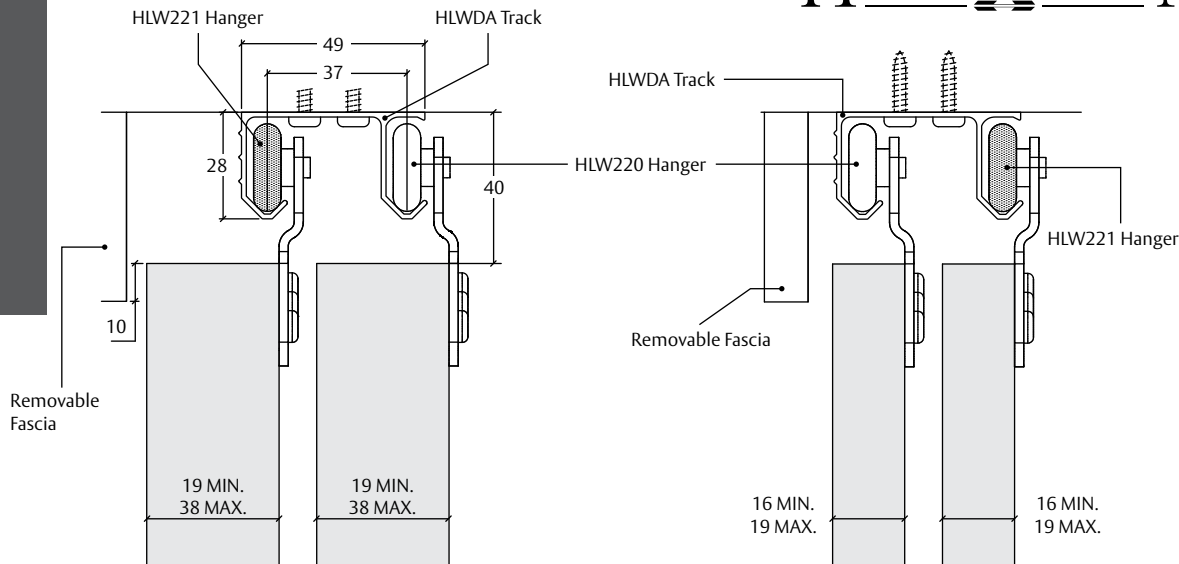

NOT TO SCALE

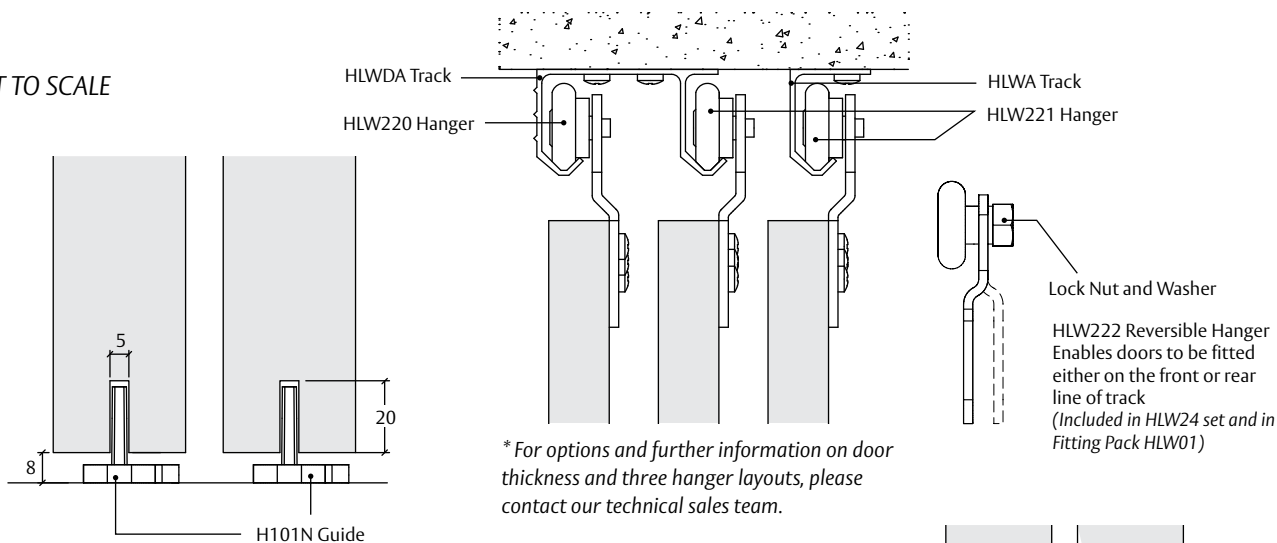

* For options and further information on door thickness and three hanger layouts, please contact our technical sales team.

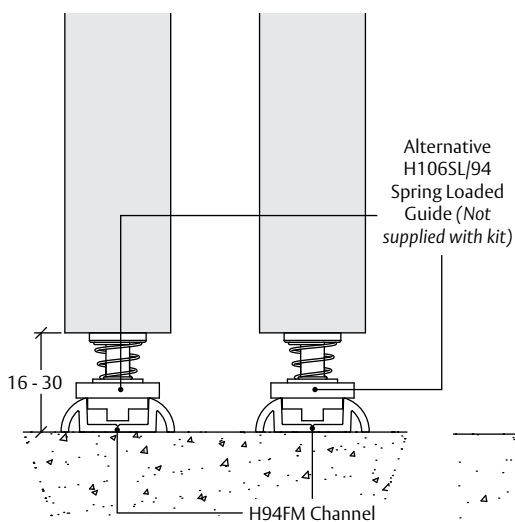

Double Top Lite – 2 Door Application

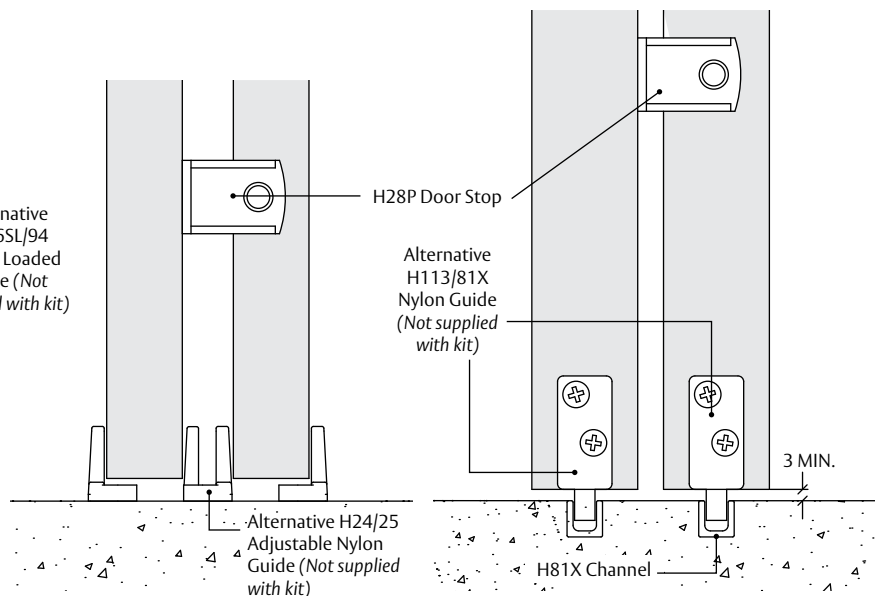

Double Top Lite – 3 Door Application

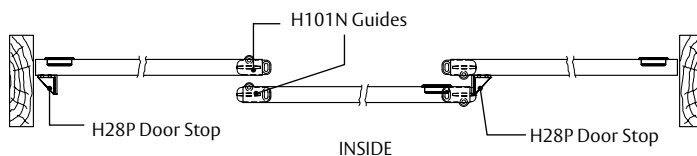
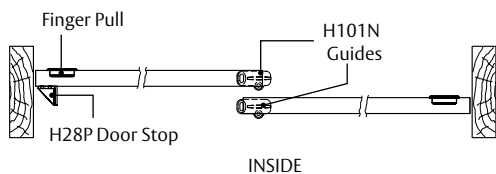

SWIFT

For top hung sliding doors. Max 30kg each.

APPLICATION

- Ideal for residential interior top hung sliding doors
- Suitable for a single door or for two doors on a bi-parting installation - door width limits apply
- The track is sidewall fitted with provision for a 'hook-on' pelmet
- All screws are the same size and length for quick selection and easy installation

DOOR SPECIFICATION

Track System **Swift**

For Individual Doors:

Max Door Weight	30kg
Max Door Width	1500mm
Min Door Thickness	25mm

Suitable for use with lightly constructed timber framed doors of flush or panelled construction. Provision must be made for fitting the hangers securely, since the hangers strike the door stops.

STANDARD SETS AND PACK

Sets comprise of top track, 2x hangers, 2x door stops, H101N and H162 guides, all screws and installation instructions.

Set No.	Max door width	Hardware for	Track length
HS16	900mm	1 door	1600mm
HS24	1500mm	1 door	2440mm

Pack No.

HS1 The S1 is a pack of fittings only, without track, for use with one S24 set for bi-parting doors, each 720mm maximum width.

HARDWARE SPECIFICATION

Track	H30A	Aluminium (1600 & 2440mm lengths) Track includes recess for 'hook-on' pelmet.
Hangers (2 per door)	H30HDP	Steel hanger with nylon wheel
Door Stop	H30DS	Rubber buffered stop
Guides	H101N H162	Nylon saw cut guide Adjustable floor guide.
Accessories		
Pelmet and End Caps	H30PEL	Pelmet in pearl white on zinc coated steel. <i>Hooks onto track, no screws required. Supplied with End Caps made from high impact polypropylene. The end caps are a push-fit onto the pelmet. Pelmet length: 1800mm.</i>

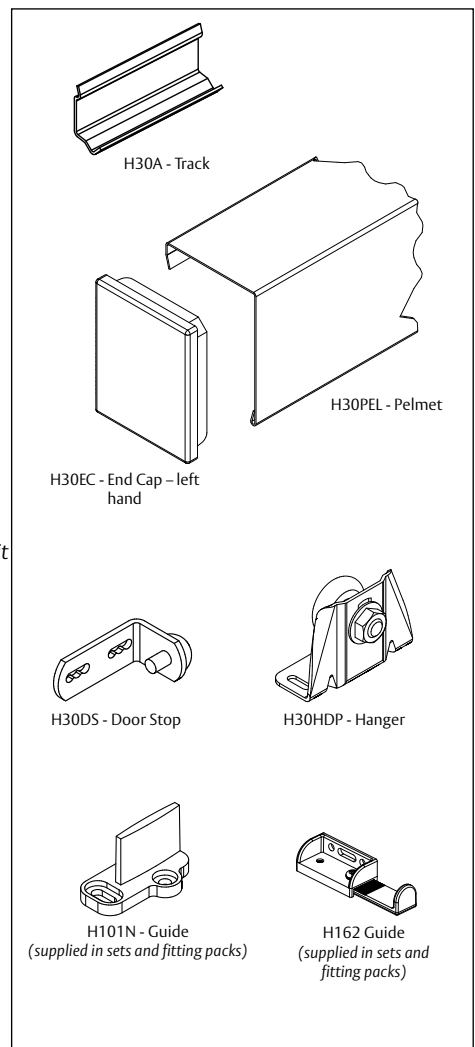

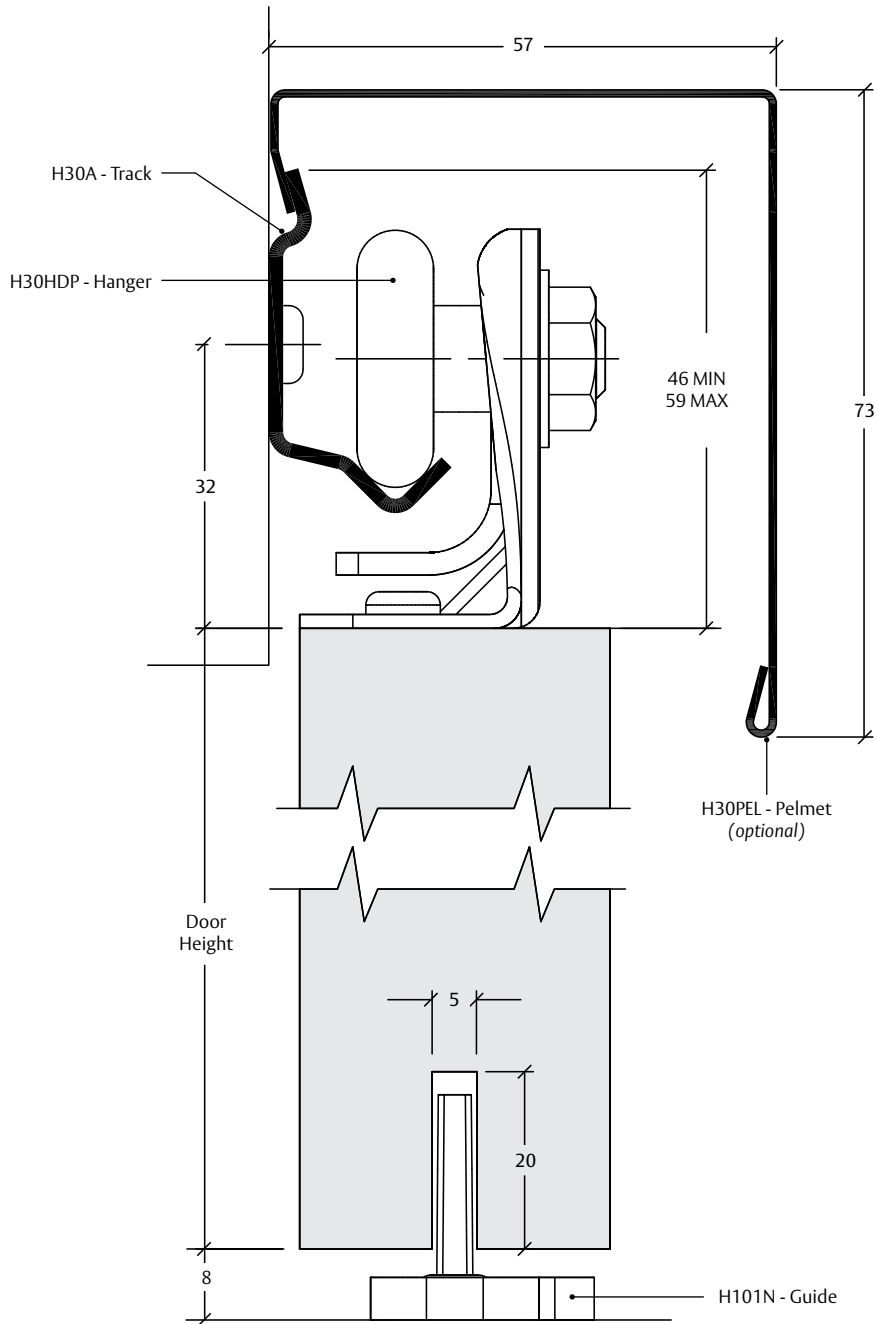

NOT TO SCALE

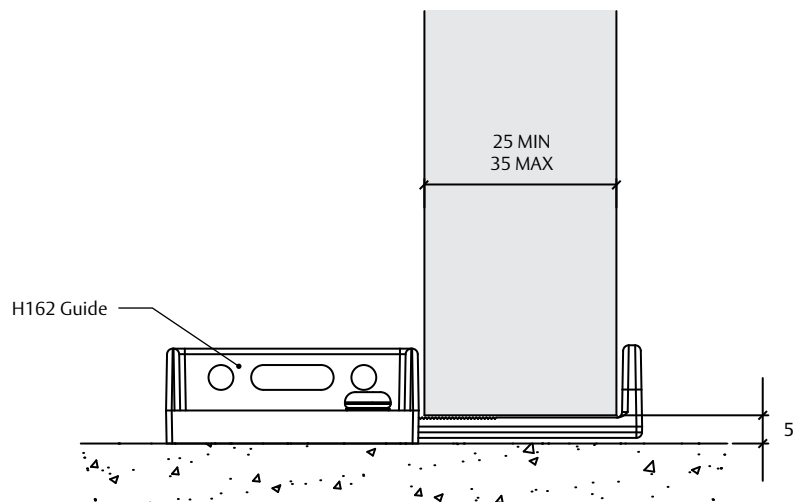

SPRINT

For top hung sliding doors. Max 30kg.

APPLICATION

- For entrance doors and doors between rooms
- For timber, timber framed or composite doors
- Silent – nylon guides and hangers on aluminium track
- Floor component – guide only

DOOR SPECIFICATION

Track System	Senator
For Individual Doors:	
Max Door Weight	30kg
Max Door Width	900mm or 1525mm
Door Thickness	20-35mm
Max Door Height	2400mm

STANDARD SETS AND PACK

Sets comprise of jump-proof, face/soffit fixing aluminium section track, top fixing hangers, H162 guide, stop, all screws and fitting instructions.

Set No.	Opening width	Hardware for	Track Length
HSP3	900mm	1 door	1800mm
HSP5	1525mm	1 door	3000mm
Pack No.	Application		
HSENSP1	One door fitting kit		

HARDWARE SPECIFICATION

Track	H21A	Aluminium (3000mm length)
Hangers (2 per door)	H161	Senator hanger <i>Top fixing hangers with ball race nylon tyred wheels for smooth operation. Built in adjustability for ease of installation</i>
Door Stop	H28P	Rubber buffered stop
Guides	H101N	Nylon saw cut guide
	H162	Adjustable floor guide
	H102N	Nylon saw cut guide
Accessories		
Pelmet	H40P/1854DP	Pelmet in white on zinc coated steel. <i>Face fixes to wall. Supplied with screw on End Caps. Pelmet length: 1854mm.</i>

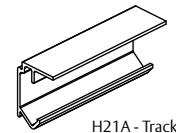

H21A - Track

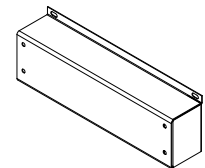

H40P/1854 - Pelmet

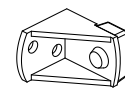

H28P - Door Stop

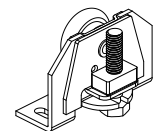

H161 - Hanger

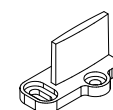

H101N - Guide

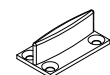

H102N - Guide

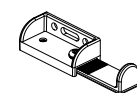

H162 Guide
(supplied in sets and fitting packs)



HENDERSON

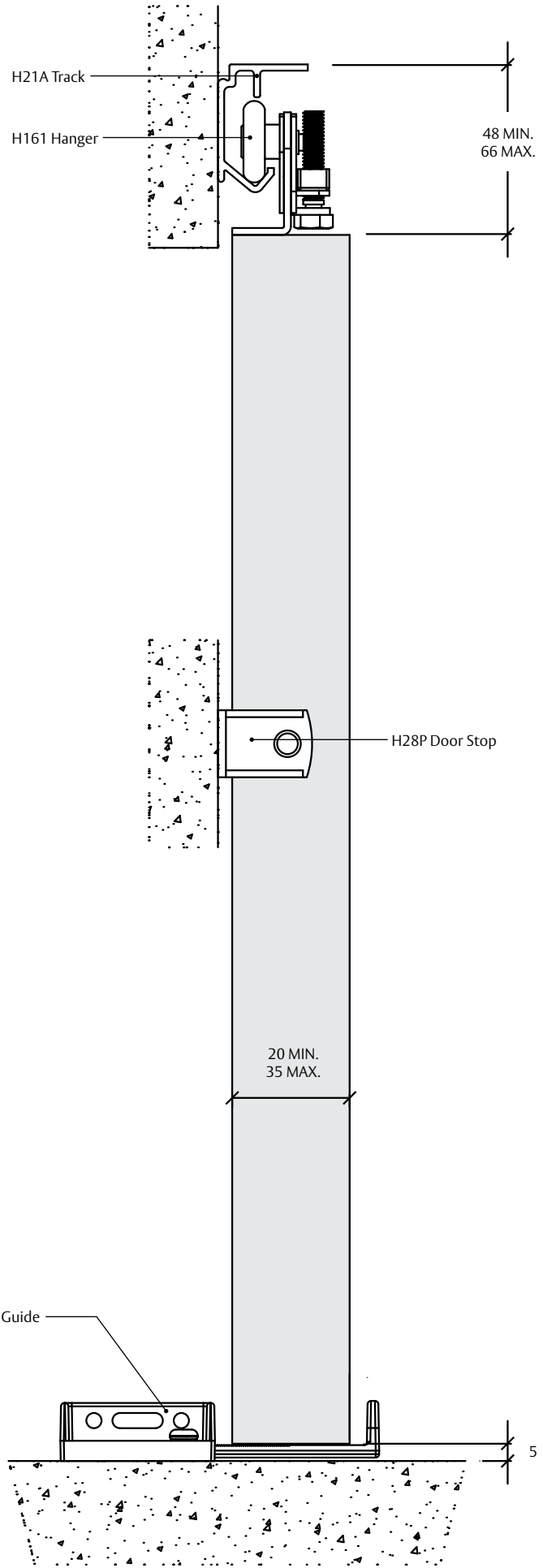

NOT TO SCALE

ISSUE 1-0515

ASSA ABLOY New Zealand Ltd. PO Box 100407, North Shore, Auckland 0745 • 6 Armstrong Road, Albany, Auckland 0632, New Zealand
Within New Zealand: Tel 09 448 9188 Fax 415 7889 www.assaabloy.co.nz • Online Catalogue: www.assaabloycatalogue.co.nz

SINGLE TOP

For single track sliding wardrobe doors. Max 45kg.

APPLICATION

- For timber framed composite doors
- Silent – nylon wheeled ball bearing hangers and aluminium track
- Easily adjusted door height
- Alternative guide channel systems available

DOOR SPECIFICATION

Track System **Single Top**

For Individual Doors:

Max Door Weight	45kg
Max Door Width	900mm
Door Thickness	16-40mm
Max Door Height	2400mm

STANDARD SETS AND PACK

Sets comprise of jump-proof, face/soffit fixing aluminium section track, ball bearing hangers, nylon guides, rubber-buffered stop, all screws and fitting instructions.

Set No.	Opening width	Track length	Hardware for
HST12	600mm	1200mm	1 door
HST15	750mm	1500mm	1 door
HST18	900mm	1800mm	1 door
Pack No.	Application		
HST01	Single door fittings pack		

HARDWARE SPECIFICATION

Track	H21A	Aluminium (3000mm length)
Hangers (2 per door)	H220	Outer offset hanger Nylon tyred wheel face fitted to the back of the door.
Door Stop	H28P	Rubber-buffered stop
Guides	H24/25	Nylon adjustable guide set <i>Included in sets and packs. Alternative guides available.</i>
Accessories		
Guides	H101N	Nylon saw cut guide
	H102N	Nylon saw cut guide
	H106SL/94	Spring loaded guide (suits H81X channel & H94FM channel)
	H113/81X	Nylon guide (suits H81X channel)
Channels	H81X	Aluminium channel (1200, 1500, 1800, 2400 & 3600mm lengths)
	H94FM	Aluminium channel (2000, 3000, 4000 & 6000mm lengths)
Pelmet	HF134/#	Fascia for soffit fixed applications for doors up to 38mm thick
	HF134/ECP	Fascia end cap pack
	HF138/#	Fascia for soffit fixed applications for doors up to 20mm thick
	HF138/ECP	Fascia end cap pack

Note: Replace # with 2000, 3000 & 4000mm lengths. All fascia anodised finish

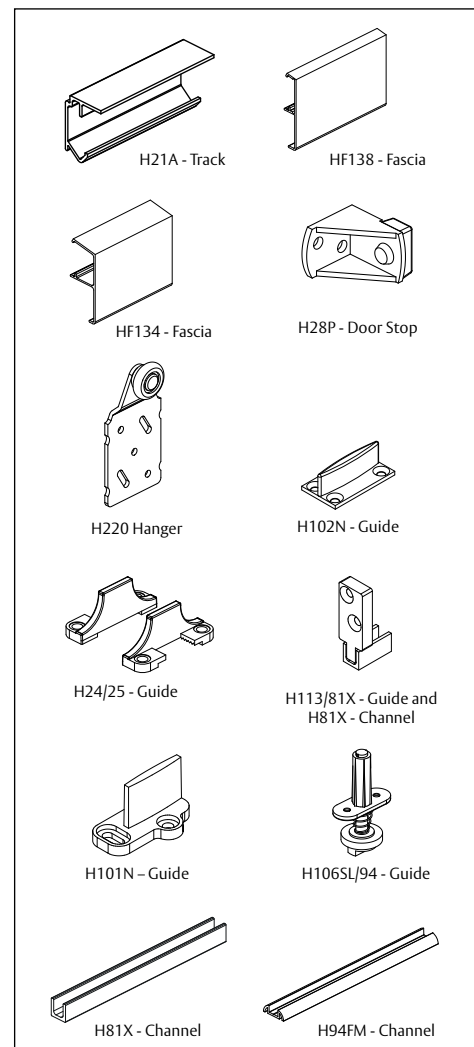



HENDERSON

NOT TO SCALE

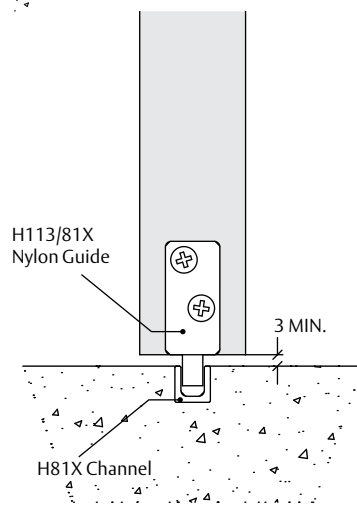
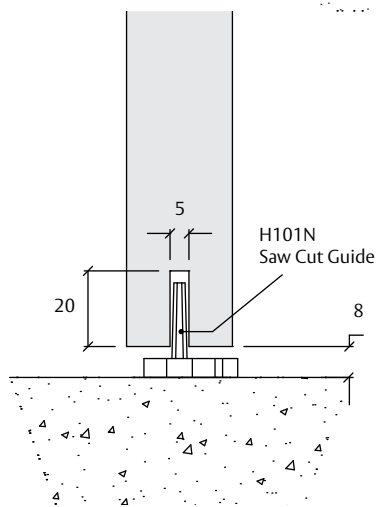
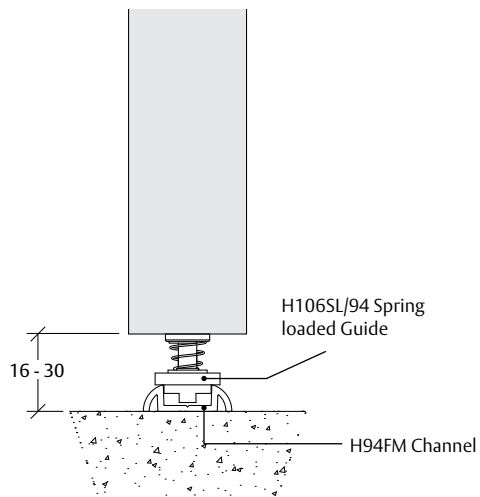
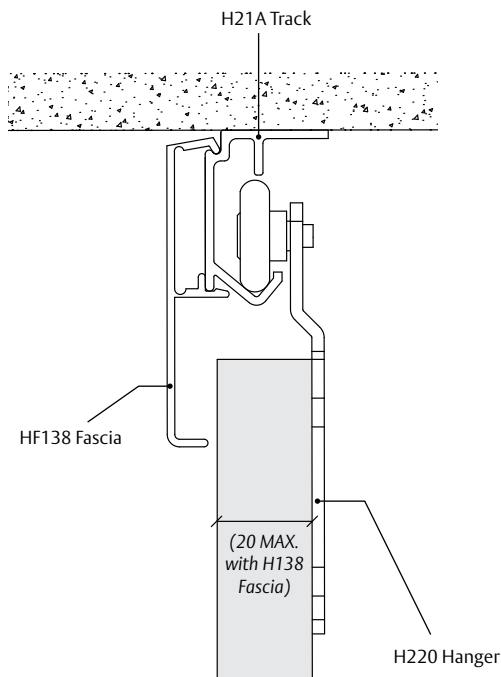
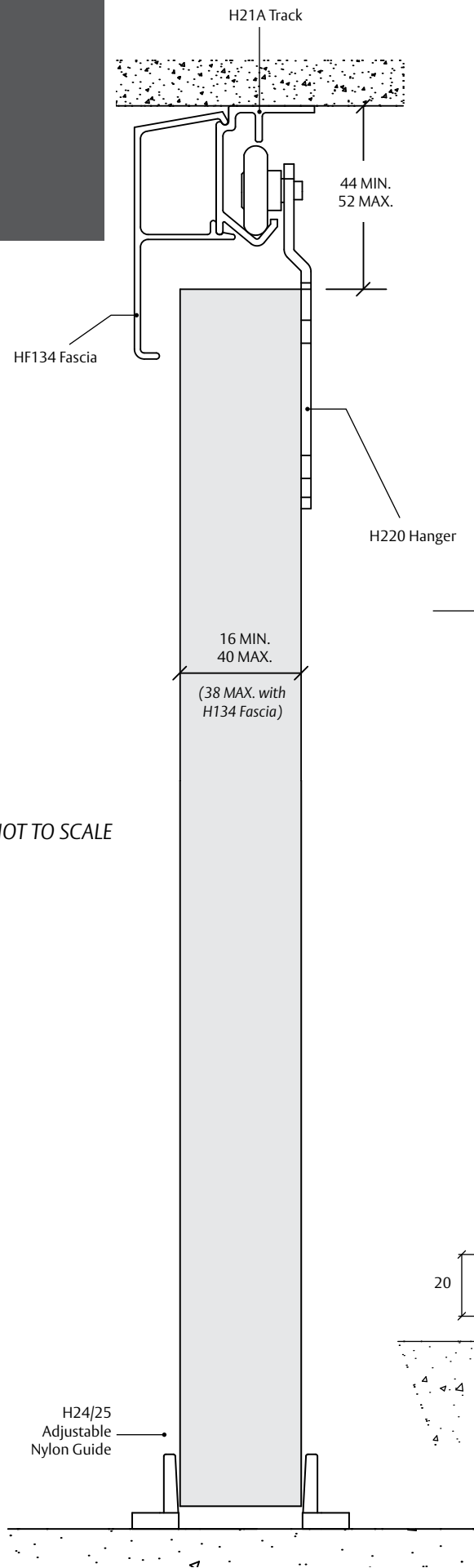

DOUBLE TOP

For double track sliding wardrobe doors. Max 45kg.

APPLICATION

- For heavy duty applications – larger wardrobes and cupboards in hotels, schools and offices
- For timber, timber framed or composite doors
- Silent – nylon wheeled ball bearing hangers and aluminium track
- Easily adjusted door height
- Alternative guide channel systems available

DOOR SPECIFICATION

Track System Double Top

For Individual Doors:

Max Door Weight	45kg
Max Door Width	900mm
Door Thickness	16-40mm
Max Door Height	2400mm

STANDARD SETS AND PACK

Sets comprise of jump-proof, face/soffit fixing aluminium section track, ball bearing hangers, nylon guides, rubber-buffered stop, all screws and fitting instructions.

Set No.	Opening width	Track length	Hardware for
HW12	1200mm	1200mm	2 doors
HW15	1500mm	1500mm	2 doors
HW18	1800mm	1800mm	2 doors
HW24	2400mm	2400mm	3 doors

Pack No.	Application
HW01	Single door fittings pack
HW02	Two door fittings pack

HARDWARE SPECIFICATION

Track	H20A	Aluminium (3000mm length)	
Hangers (2 per door)	H220	Outer offset hanger	
	H221	Inner offset hanger	
	H222	Reversible offset hanger	
Door Stop	H28P	Rubber-buffered stop	
Guides	H24/25	Nylon adjustable guide set 1 guide set for 2 doors, 2 sets for 3 doors. Included in door sets and packs. Alternative guides available.	
Accessories	Track	H21A Aluminium single track (3000mm length)	
	Guides	H101N	Nylon saw cut guide
		H102N	Nylon saw cut guide
		H106SL/94	Spring loaded guide (suits H81X channel & H94FM channel)
		H113/81X	Nylon guide (suits H81X channel)
Channels	<i>For heavy duty applications or where more than 3 doors are required per opening</i>		
	H81X	Aluminium channel (1200, 1500, 1800, 2400 & 3600mm lengths)	
	H94FM	Aluminium channel (2000, 3000, 4000 & 6000mm lengths)	
Pelmet	HF134/#	Fascia for soffit fixed applications for doors up to 38mm thick	
	HF134/ECP	Fascia end cap pack	
	HF138/#	Fascia for soffit fixed applications for doors up to 20mm thick	
	HF138/ECP	Fascia end cap pack	

Note: Replace # with 2000, 3000, 4000mm lengths. All fascia anodised finish

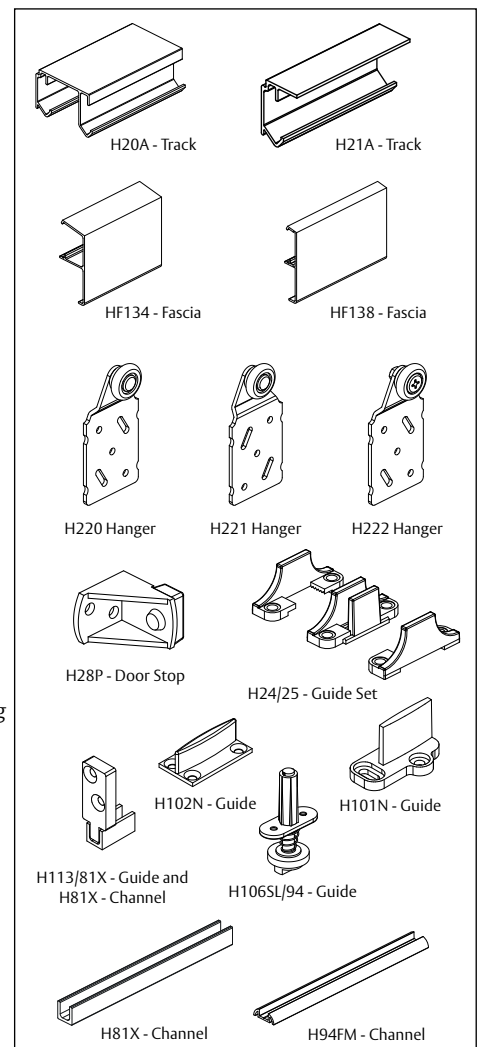



HENDERSON

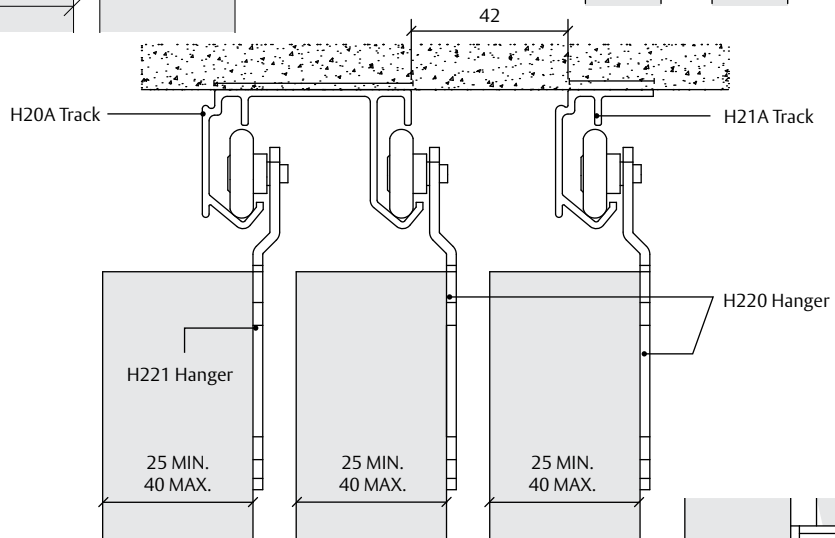
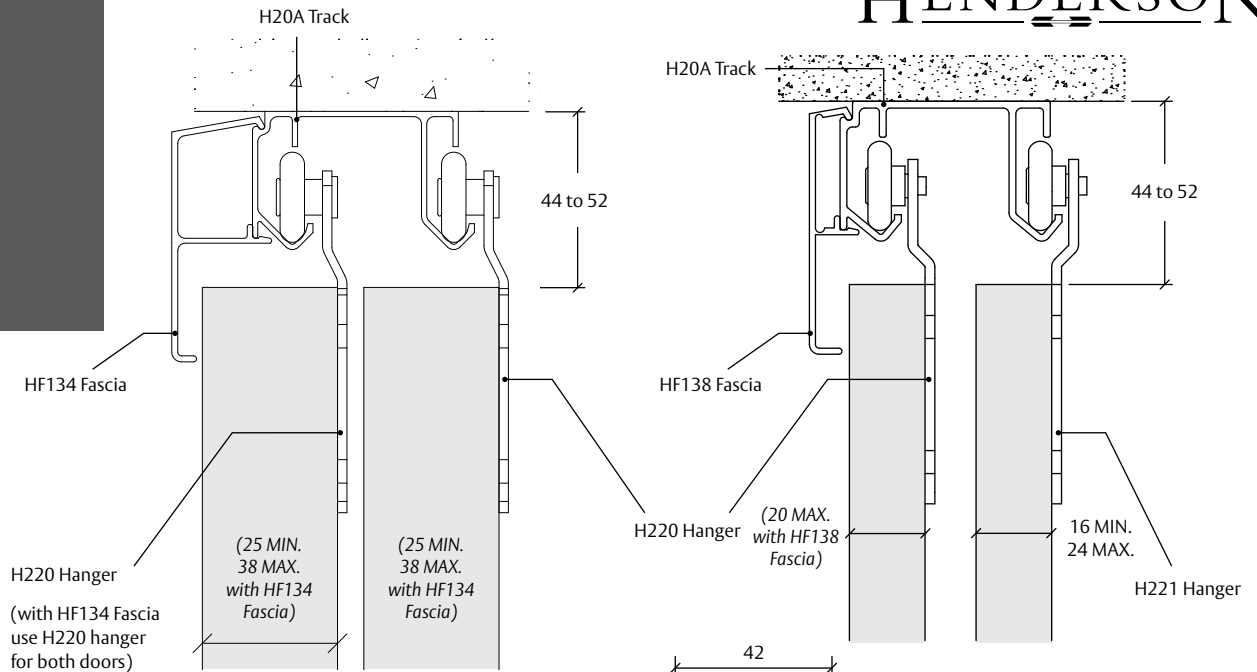

NOT TO SCALE

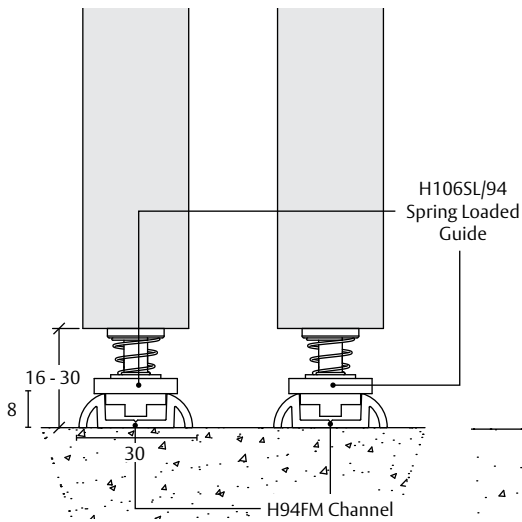

Double Top – 2 Door Application

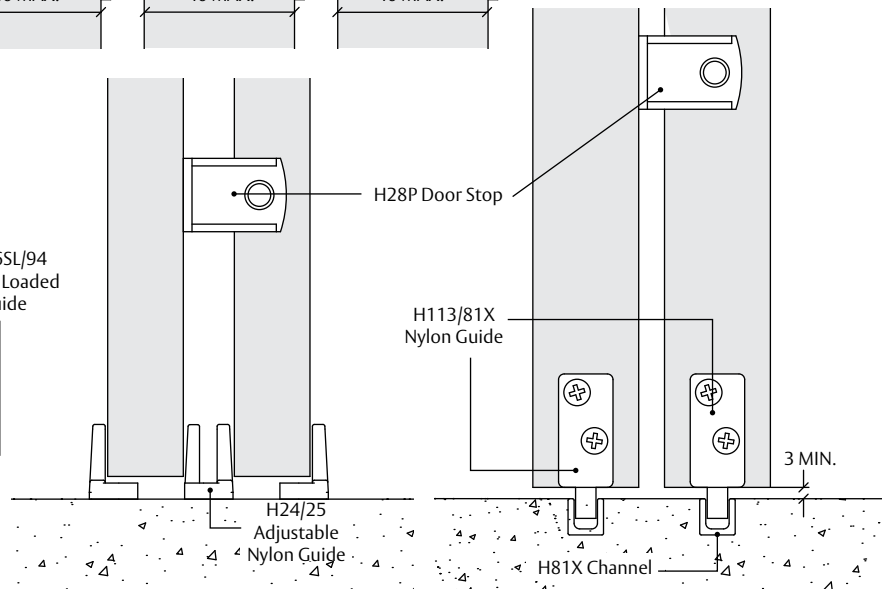

Double Top – 3 Door Application

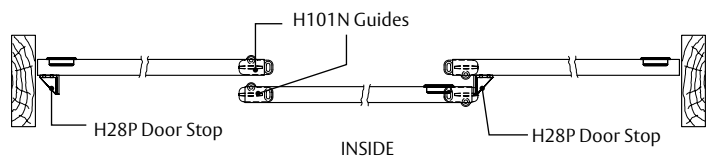
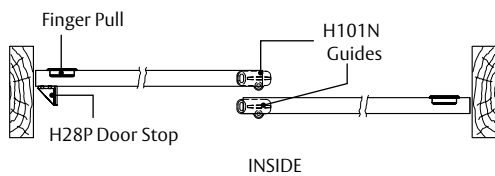

MARATHON 55 & 90

For sliding doors. Max 55kg or 90kg.

APPLICATION

- Used for heavy-duty domestic and light commercial applications, doors and partitions
- For timber, timber framed or composite doors
- Easily adjusted door height
- Simultaneous action option
- Fire door kit option available for Marathon 90

DOOR SPECIFICATION

Track System	Marathon 55	Marathon 90
For Individual Doors:		
Max Door Weight	55kg	90kg
Max Door Width	1500mm	1500mm
Door Thickness	32-50mm	32-50mm
Max Door Height	3000mm	3000mm

STANDARD SETS AND PACK

Sets comprise of top assembly, nylon top plates, floor guide, nylon, channel, wall mounted stop, all screws and fitting instructions.

Marathon 55 Set No.	Marathon 90 Set No.	Door width	Track length	Hardware for
HJ2	HS2	400-750mm	1219mm	1 door
HJ3	HS3	750-900mm	1473mm	1 door
HJ4	HS4	900-1050mm	1702mm	1 door
HJ5	HS5	1050-1200mm	1981mm	1 door
HJ6	HS6	1200-1500mm	2438mm	1 door

HARDWARE SPECIFICATION

Top plate (2 per door)	H43	Nylon top plate with integral buffer (<i>not supplied with bolt</i>)
Stop	H44	Wall mounted stop
Guides	H101N H102N H102N/93	Nylon saw cut guide Nylon saw cut guide Floor mounted channel guide
Channels	H94X	Aluminium (<i>2000, 3000, 4000 & 6000mm lengths</i>)
Accessories		
Self closing kit	H5CK1	For doors up to 60kg
Pelmet	H40P/1854 HEC40P H40P/1854P HEC40PW	Galvanised fascia for face fixed applications (<i>HJ3 and HS3 sets only</i>) Galvanised fascia end cap pack Artic white fascia for face fixed applications (<i>HJ3 and HS3 sets only</i>) Artic white fascia end cap pack
Bracket	H3/40	Soffit fix brackets (<i>pack of 5</i>)
Fire door kit	HFDK1 HFDK2	Self closing fire door kit. For use in conjunction with Marathon kits S3, S4, S5 & S6 (<i>purchased separately</i>) Non-self closing fire door kit. For use in conjunction with Marathon kits S3, S4, S5 & S6 (<i>purchased separately</i>)
Simultaneous Action Kit	H23	For biparting doors up to 60kg

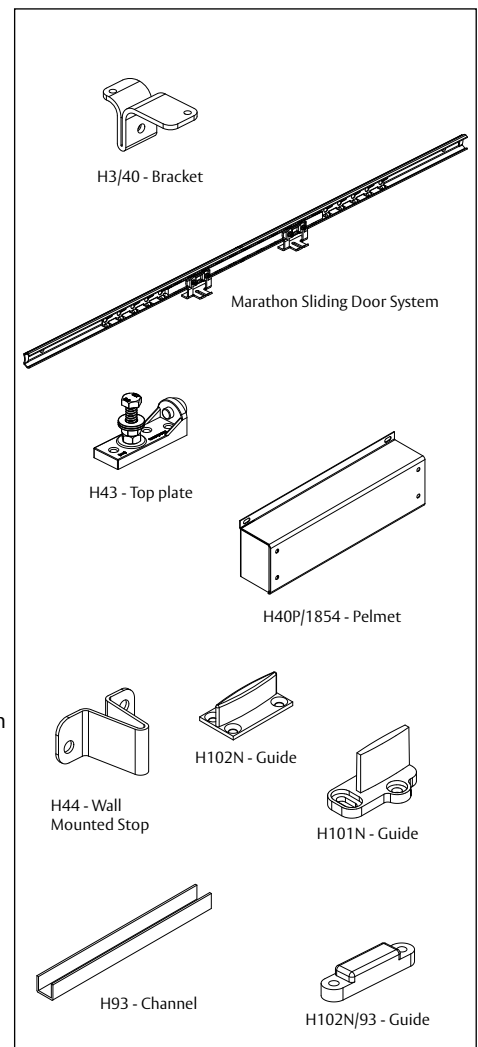

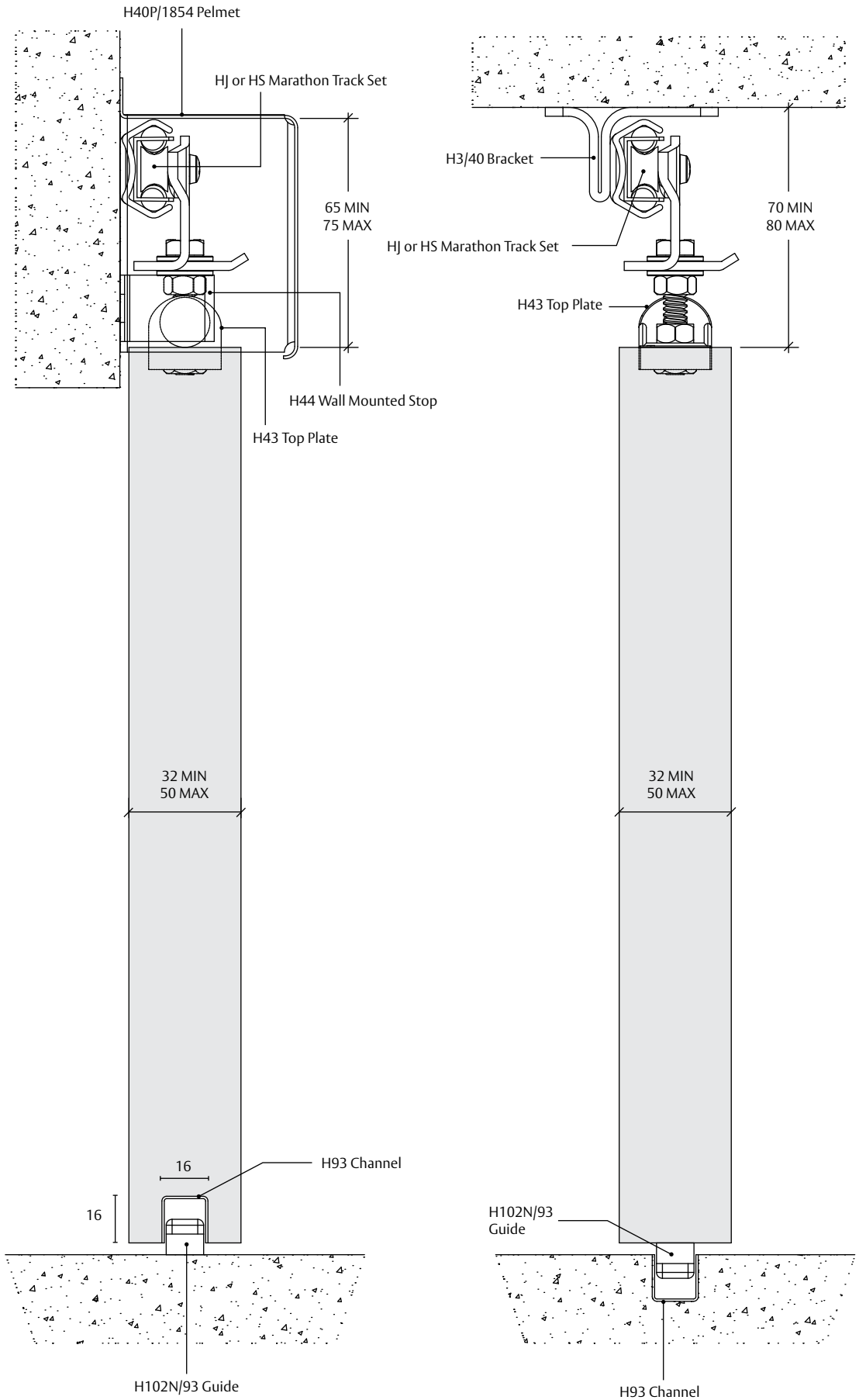

HENDERSON

ISSUE 1-0515

ASSA ABLOY New Zealand Ltd. PO Box 100407, North Shore, Auckland 0745 • 6 Armstrong Road, Albany, Auckland 0632, New Zealand
 Within New Zealand: Tel 09 448 9188 Fax 415 7889 www.assaabloy.co.nz • Online Catalogue: www.assaabloycatalogue.co.nz

RUSTIC 80

For top hung interior sliding timber doors. Max 80kg each leaf.

APPLICATION

- Traditional system for timber doors that creates that old fashioned look
- Exposed steel straps fasten down the front of the door to support that rustic finish whilst the beautiful crafted hangers run smoothly along a flat bar track
- Robust black powdercoat provides a durable finish
- Nylon bearing wheels provide a smooth and silent running
- Stops are position on the track to limit door travel

DOOR SPECIFICATION

Track System	Rustic 80
For Individual Doors:	
Max Panel Weight	80kg
Min Panel Width	500mm
Max Panel Width	1500mm
Panel Thickness	36-46mm
Max Panel Height	3000mm

STANDARD SETS AND PACK

Sets comprise of 2 x hangers, 2 x door stops, 2 x flush pulls, 1 x floor guide, 1 x flat track (2M or 3M) track wall spacers and fixings for solid walls.

Set No.	Opening Width	Track Length	Hardware for
HR80/20	1000mm	2000mm	1 door
HR80/30	1500mm	3000mm	1 door



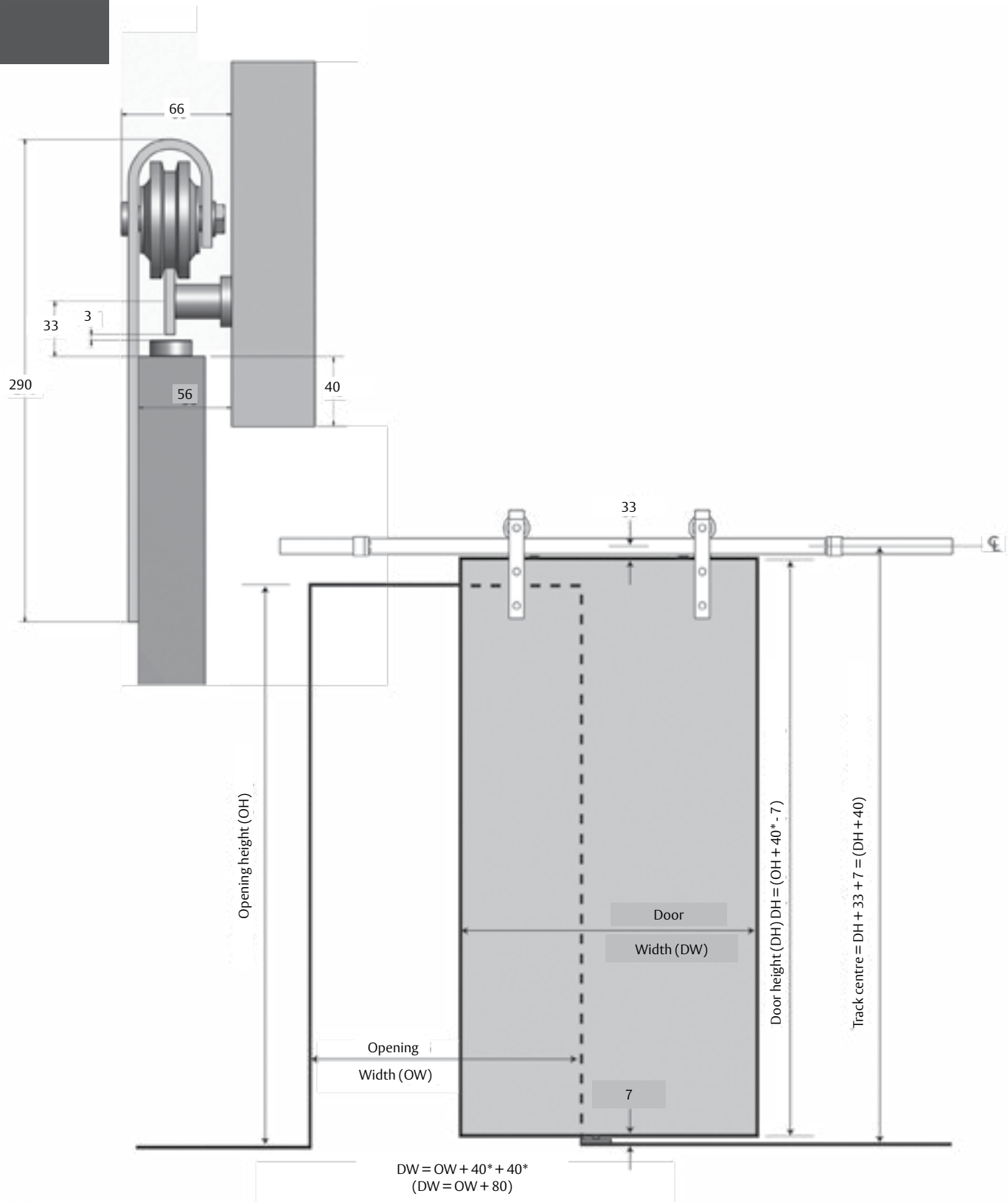

*PCH Suggests 40mm overlap of the door to the opening.

All dimensions in mm.

SIROCCO SELF CLOSING SYSTEM

For sliding timber and metal doors. Max. 80kg.

APPLICATION

- Suitable for both domestic and commercial interior applications
- Designed to give a smooth and quiet operation, with a hydraulically controlled soft close feature
- Adjustable closing speed feature
- Door brake to reduce opening speed to prevent damage to the door and system
- Operational between temperature ranges of -10°C to 40°C
- Optional hold open unit giving adjustable time delay before self closing

DOOR SPECIFICATION

Track System	Sirocco
For Individual Doors:	
Max Door Weight	80kg
Min Door Width	800mm
Max Door Width	1200mm
Door Thickness	30-46mm

STANDARD SETS AND PACK

Sets comprises of aluminium track (2200mm), hangers, hydraulic control unit, power spring unit, door stops, guides, roller, all screws and fitting instructions.

Pack No.	Application
HSIRRH	Right Hand Opening
HSIRLH	Left Hand Opening
HDELRH	Delayed Closing Timer – Right Hand
HDELLH	Delayed Closing Timer – Left Hand

HARDWARE SPECIFICATION

Guides	H102SS/94	Timber doors - wall mounted and multiple run guide
	H105SS/94	Timber doors - face mounted guide
	H106SS/94	Timber doors - concealed fixing with SS bearing
Channels	H94X	Aluminium (2000, 3000, 4000 & 6000mm lengths)
	H94	Brass (4000 & 6000mm lengths)
	H94P	Polypropylene (2000, 3000, 4000 & 6000mm lengths)
	H94PSC	Aluminium supporting channel and polypropylene (2000, 3000, 4000 & 6000mm lengths)

Accessories

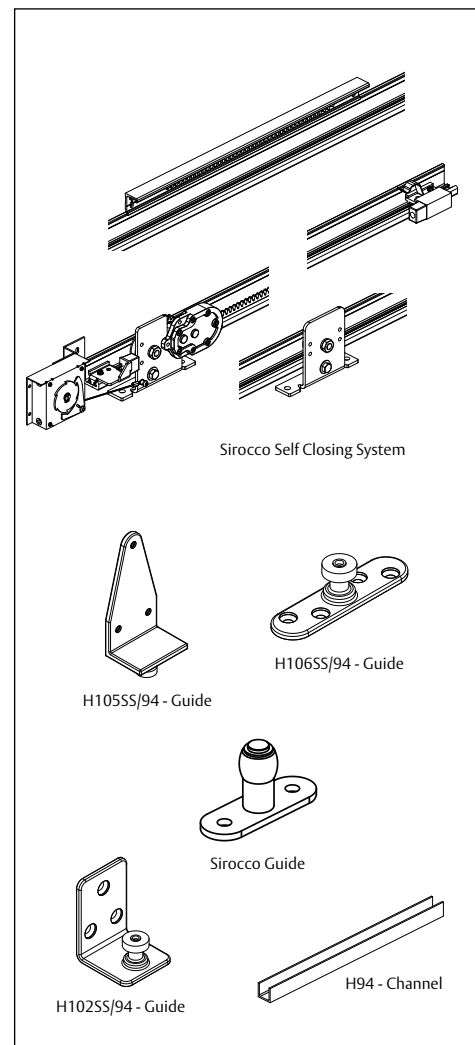

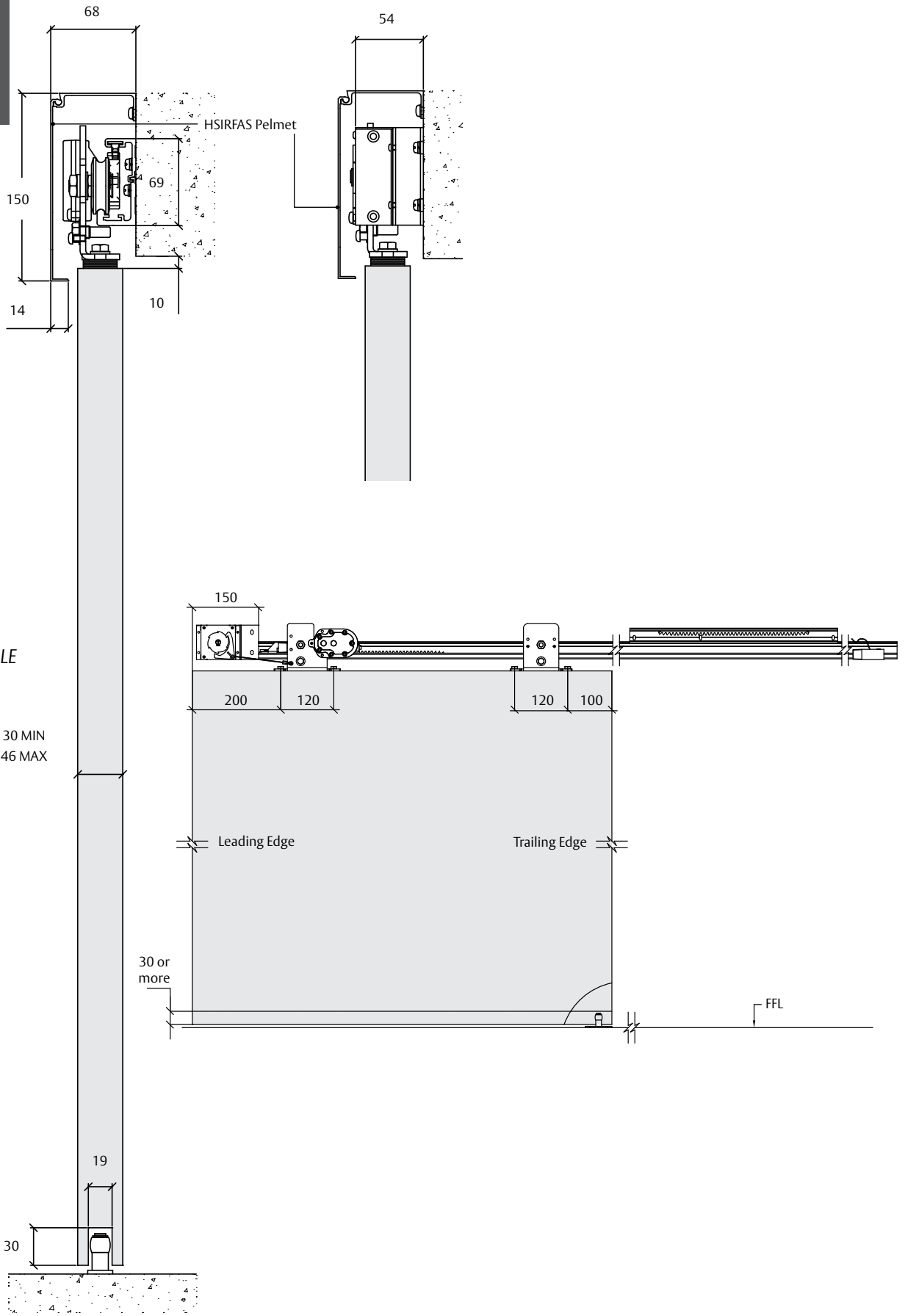

NOT TO SCALE

30 MIN
46 MAX

30 or
more

FFL

HENDERSON

ISSUE 1-0515

ASSA ABLOY New Zealand Ltd. PO Box 100407, North Shore, Auckland 0745 • 6 Armstrong Road, Albany, Auckland 0632, New Zealand
 Within New Zealand: Tel 09 448 9188 Fax 415 7889 www.assaabloy.co.nz • Online Catalogue: www.assaabloycatalogue.co.nz

B100B

The global leader in door opening solutions.

ASSA ABLOY

HUSKY 50 & 100

For sliding timber and metal doors. Max. 50kg or 100kg.

APPLICATION

- Ideally suited for room dividers and wardrobe doors
- Quiet operation – galvanised steel or aluminium track with nylon rollers
- Suitable for timber, timber framed, composite or metal framed doors

DOOR SPECIFICATION

Track System	Husky 50	Husky 100
For Individual Doors:		
Max Door Weight	50kg	100kg
Max Door Width	1250mm*	1250mm*
Door Thickness	20-50mm	20-50mm
Max Door Height	2400mm	2400mm

* Max door width using Husky sets. Wider doors can be accommodated by ordering track and door components separately.

STANDARD SETS AND PACK

Sets comprise of aluminium track, 2x hangers, 1x clip stop, 1x track stop, 1x saw cut guide, face fix brackets, all screws & fitting instructions.

Husky 50 Steel	Husky 100 Steel	Husky 50 Aluminium	Husky 100 Aluminium	Track Length	Hardware For
H50/15	H100/15	H50/15A	H100/15A	1500mm	1 door
H50/18	H100/18	H50/18A	H100/18A	1800mm	1 door
H50/20	H100/20	H50/20A	H100/20A	2000mm	1 door
H50/24	H100/24	H50/24A	H100/24A	2400mm	1 door

Pack No.	Application
H50N	Single door fittings pack 50kg.
H100	Single door fittings pack 100kg.

HARDWARE SPECIFICATION

Track	H280	Steel (2000, 3000, 4000 & 6000mm lengths)
	H280A	Aluminium (2000, 3000, 4000 & 6000mm lengths) Soffit fix spacing 275mm centres (maximum)
Brackets	H281	Face fixed steel (for steel track)
	H281A	Face fixed aluminium (for aluminium track)
	H281AX	End and jointing bracket aluminium (for aluminium track) Spacing 275mm centres (maximum)
Hangers	H284N	Nylon bodied, acetal wheel hangers (Husky 50)
(2 per door)*	H284	Nylon bodied, needle roller bearings 4-wheel hangers (Husky 100)
* Each panel must be rigid enough to be supported by only two hangers		
Clip Stop	H601H	Adjustable retaining stop
Track Stop	H287	Rubber buffer stop
Guides	H102N	Nylon saw cut guide
	H106N/94	Roller guide. Steel plate with nylon roller
	H106SL/94	Spring loaded guide (suits H81X channel & H94FM channel)
Channels	H94FM	Aluminium (2000, 3000, 4000 & 6000mm lengths)
	H94X	Aluminium (2000, 3000, 4000 & 6000mm lengths)
Accessories		
Fascia	HF134/#	Fascia for soffit fixed applications for doors up to 50mm thick
	HF134/ECP	Fascia end clip pack
	HF138/#	Fascia for soffit fixed applications for doors up to 25mm thick
	HF138/ECP	Fascia end clip pack
	HF140/#	Fascia for face fixed applications for doors up to 50mm thick (includes end caps)

Note: Replace # with 2000, 3000, 4000 & 6000*mm lengths. *HF140 only

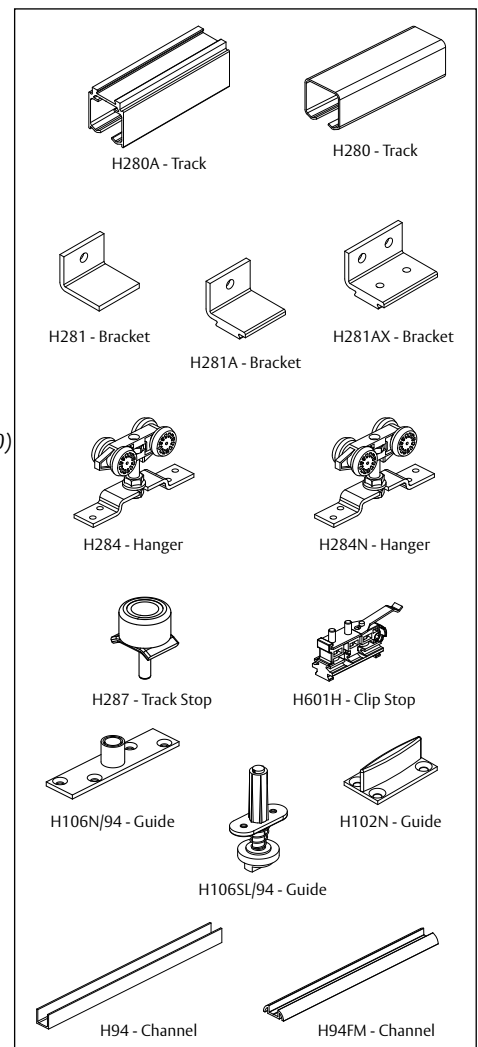

Aluminium Track

Steel Track

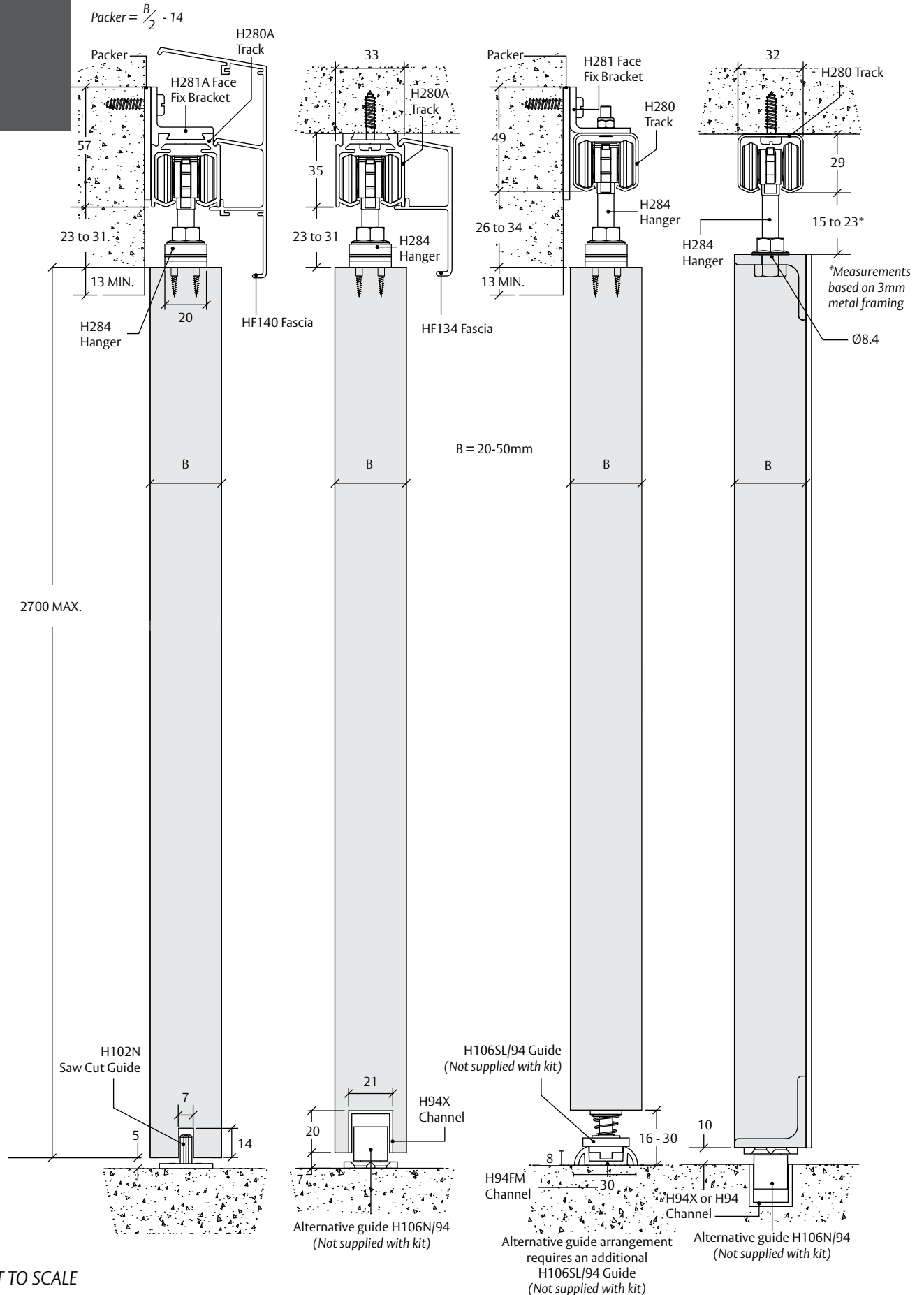

NOT TO SCALE

ASSA ABLOY New Zealand Ltd. PO Box 100407, North Shore, Auckland 0745 • 6 Armstrong Road, Albany, Auckland 0632, New Zealand
 Within New Zealand: Tel 09 448 9188 Fax 415 7889 www.assaabloy.co.nz • Online Catalogue: www.assaabloycatalogue.co.nz

UNIVERSAL TELESCOPIC

Maximum door weight:
Husky = 80kg each. Soltaire 120 = 120kg

APPLICATION

- All doors connected to universal telescopic systems will traverse simultaneously
- The door leaves are linked together via toothed belt and pulley system
- The universal telescopic HUTEL/2 & 80/3 HUTEL/3 allow 2 & 3 door leaves to be concealed in one wall on
- The same side maximising the opening and reducing the wall space required
- The door leaves are linked together via a toothed belt and pulley
- The telescopic system is non-handed

DOOR SPECIFICATION

Track System	Husky	Soltaire
Max Door Weight	80kg	120kg
Min Door Width	500mm	500mm
Max Door Width	1200mm	120mm
Door Thickness	32-47mm	35-47mm

HARDWARE SPECIFICATION

HUTEL/2 2 Door Kit (contains)

- 1 x Short bearing
- 1 x Door mounted belt fixing bracket
- 1 x Length of toothed belt
- 1 x Following door guide
- 1 x Fixed base floor guide
- 1 x Long bearing wheel assembly
- 1 x Wall mounted belt fixing

HUTEL/3 3 Door kit (contains)

- 2 x Short bearing
- 2 x Door mounted belt fixing bracket
- 2 x Length of toothed belt
- 2 x Following door guide
- 1 x Fixed base floor guide
- 2 x Long bearing wheel assembly
- 1 x Wall mounted belt fixing

Required extras

Hangers

- Husky **H284**
- Soltaire **H51/120/SS**

Track Stops

- Husky **H287 or H601**
- Soltaire **HHH4/SS**

Track

- Husky **H280A**
Available in 2000,3000, 4000 & 6000mm lengths.

Soltaire

- H120A**
Available in 2000,3000, 4000 & 6000mm lengths.

For guides and other accessories please see data sheets Husky 100 & Soltaire 120.

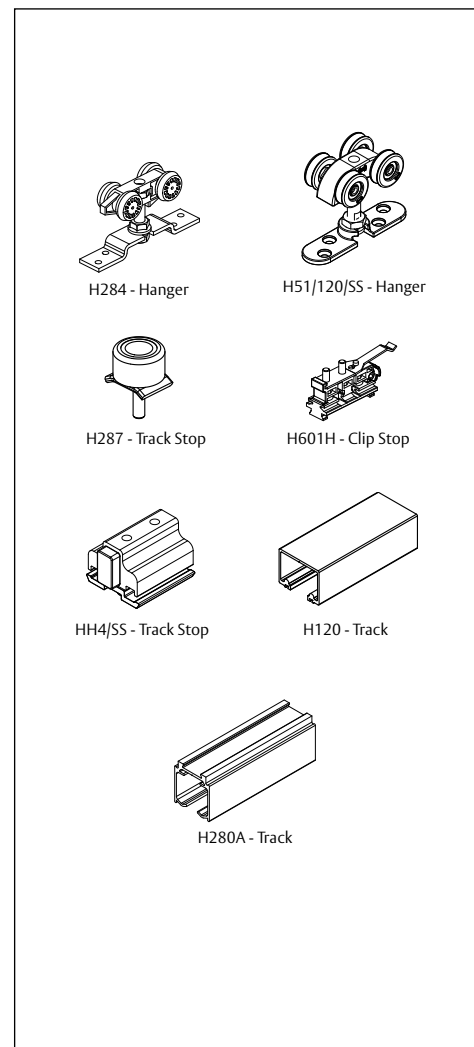

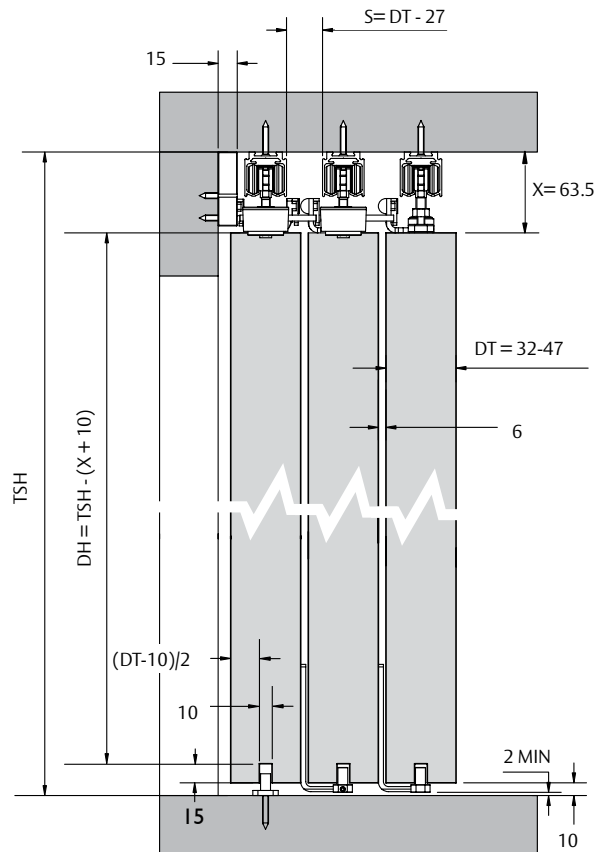
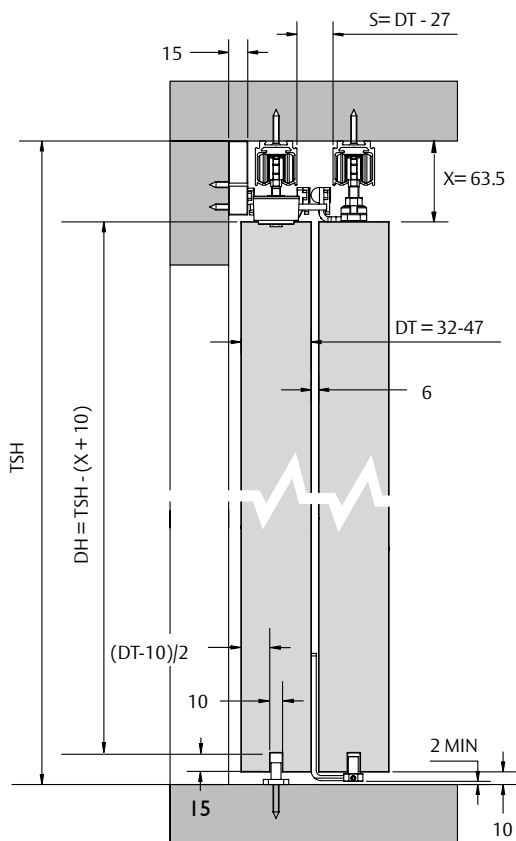
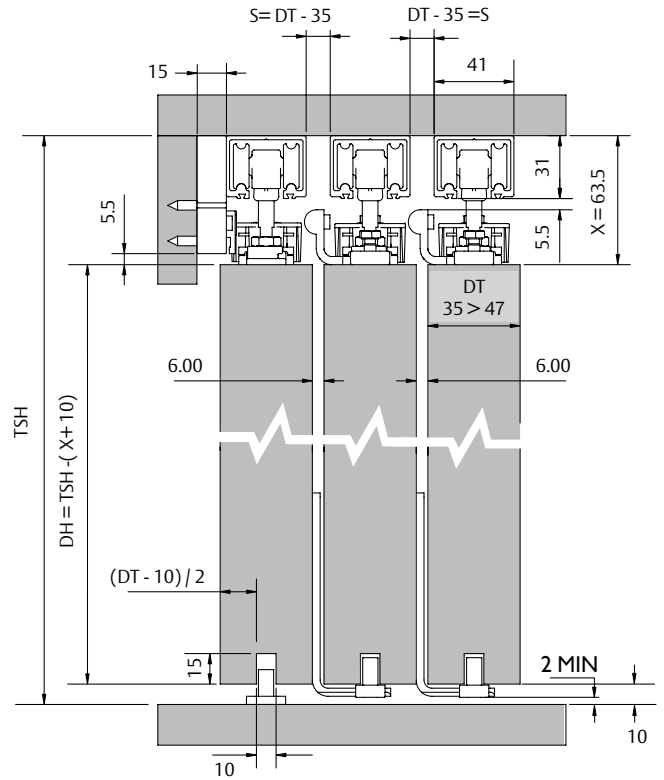
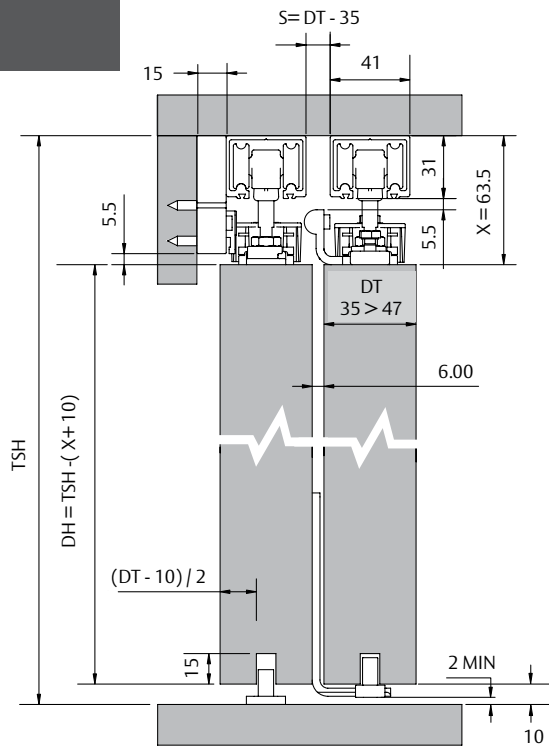

SIM 100 (for Husky)

Simultaneous action kit for bi-parting doors. Max. 100kg.

APPLICATION

- Designed for internal bi-parting panels
- To be used in conjunction with the Husky 100 system
- For internal partition bi-parting timber, timber framed or composite panels
- Kit can be retro fitted to existing installations
- Ideal for pairs of doors opening in to pocket walls
- For use with either steel or aluminium Husky track
- The system uses polypropylene coated cable for quiet operation, plastic pulley wheels rotating on ball bearings to provide reliable operation and a tension spring providing smooth operation

DOOR SPECIFICATION

Simultaneous Action Kit	SIM 100
Max Door Weight	100kg
Minimum Door Weight	25kg
Max Door Width	1250mm
Door Thickness	25-50mm
Max Door Height	2400mm
Door Material	Timber

STANDARD SETS AND PACK

Set No.	Opening width	Hardware for
SIM100	2400mm	2 doors

SET COMPRISES OF

- 1 Polypropylene coated cable with 1 Fixed loop
- 2 Pully assemblies with extended bolts
- 1 Adjuster bolt with nut
- 1 RH door bracket
- 1 LH door bracket
- 1 Cable collar with grub screws
- 1 Thimble inset
- 1 Cable clamp
- 1 Spring
- 1 Fitting instructions

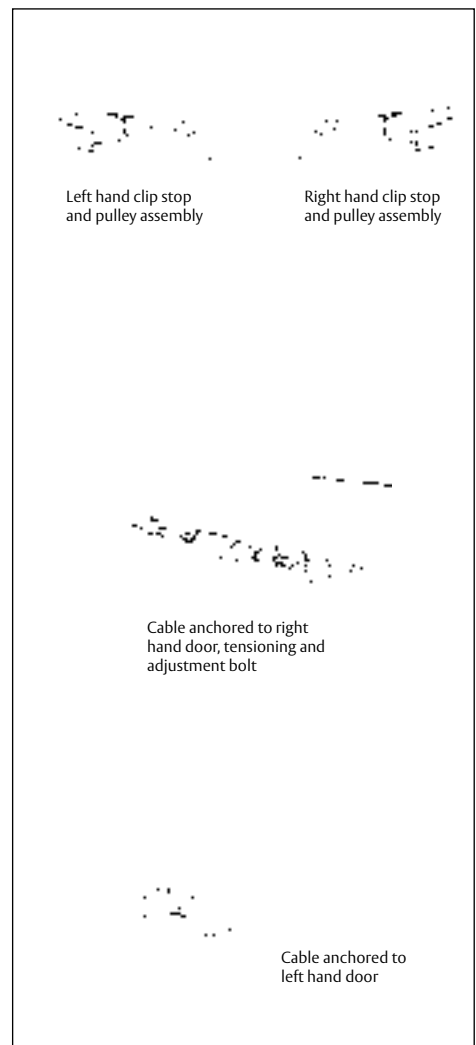

HENDERSON

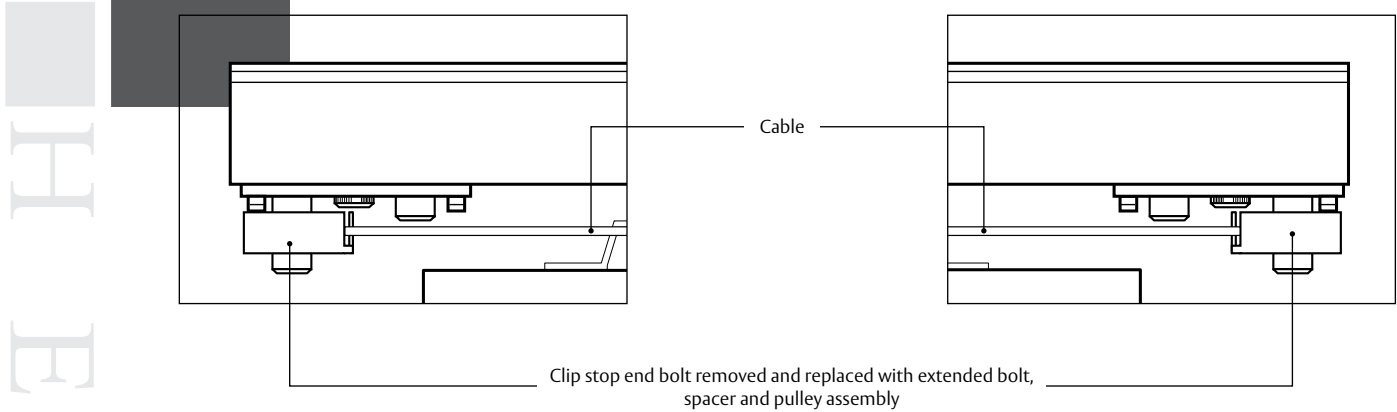

Left hand clip stop and pulley assembly

Right hand clip stop and pulley assembly

Elevation view of system

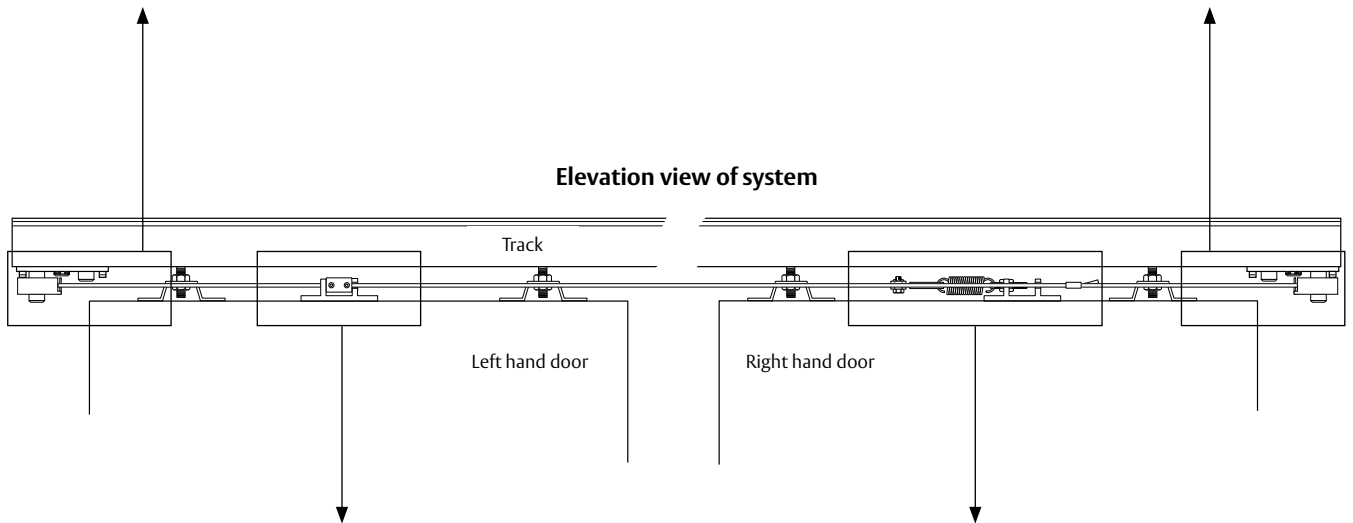

Cable anchored to left hand door

Cable anchored to right hand door, tensioning and adjustment bolt

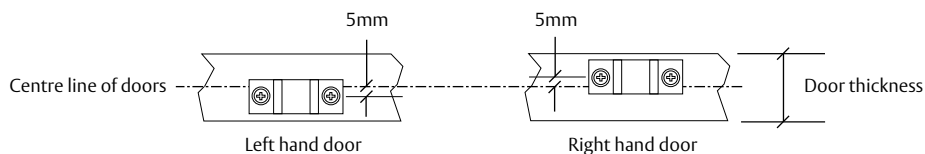
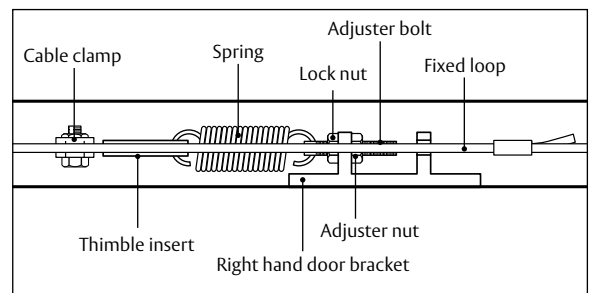
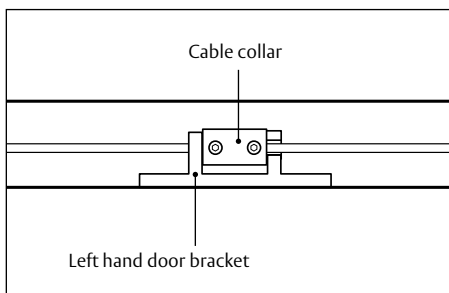

HUSKY LOW HEADROOM 100

For timber top hung sliding doors. Max 100kg.

APPLICATION

- Designed to create a modern minimalist finish with all parts concealed
- Can reduce the clearance between the track and the top of the door to 2mm
- Vertically adjustable sliding door kit for low or restricted headroom applications
- Designed to accommodate single or multiple panels on one or more tracks
- Used to maximise door height
- Engineered for easy installation and adjustment

DOOR SPECIFICATION

Track System **Low Headroom 100**

For Individual Door Leaves:

Max Door Weight	100kg
Door Thickness	34-50mm*
Max Door Height	2700mm

* For doors thicker than 50mm, please contact our technical sales team for further information.

STANDARD SETS AND PACK

Sets comprise of 2x Low Headroom units, 2x end caps, 2x clip stops, 1x saw cut guide, all screws and fitting instructions.

Pack No.	Application
HLH100	1 door pack

HARDWARE SPECIFICATION

Track	H280A	Aluminium (2000, 3000, 4000 & 6000mm lengths)
	H280AN	Anodised Aluminium (2000, 3000, 4000 & 6000mm lengths)
		<i>Soffit fix spacing 275mm centres (maximum)</i>
Brackets	H281A	Face fixed aluminium
	H281AX	End and jointing bracket aluminium
	H2815A	Bracket pack, 5 piece pack includes 2x H281AX <i>Spacing 275mm centres, use H281AX at either end of track</i>
Guides	H102N	Nylon saw cut guide
	H102SS/94	Timber doors - for multiple runs of doors
	H106SL/94	Spring loaded guide
	H106SS/94	Timber doors - concealed fixing with SS bearing
Channels	H94X	Aluminium (2000, 3000, 4000 & 6000mm lengths)
	H94FM	Aluminium (2000, 3000, 4000 & 6000mm lengths)
	H94P	Polypropylene (2000, 3000, 4000 & 6000mm lengths)
	H94PSC	Aluminium supporting channel and polypropylene (2000, 3000, 4000 & 6000mm lengths)
Accessories	Interlocking Seal	
	H59BZ/4800	Bronze anodised (4800mm to suit typical 2400mm door height)
	H59CA/4800	Clear anodised aluminium (4800mm to suit typical 2400mm door height) <i>Drilled and countersunk. Includes brush seal.</i>

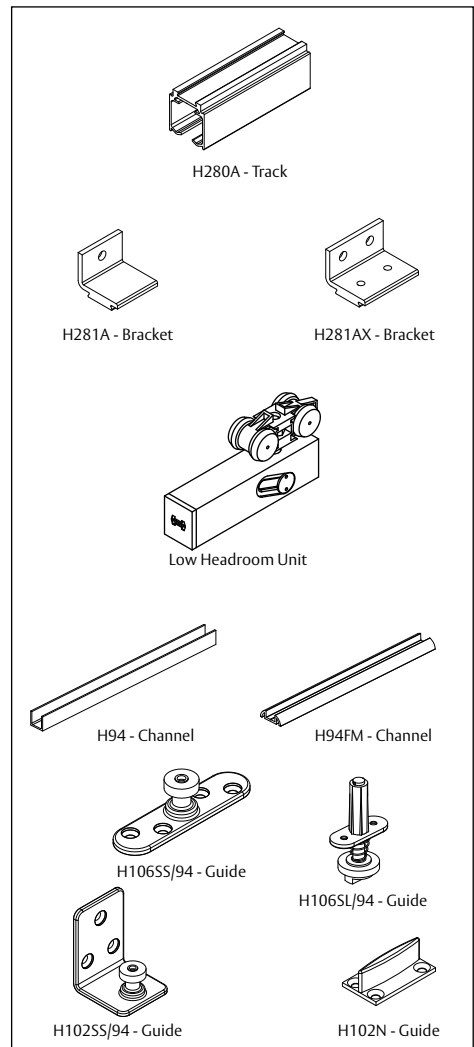

HENDERSON

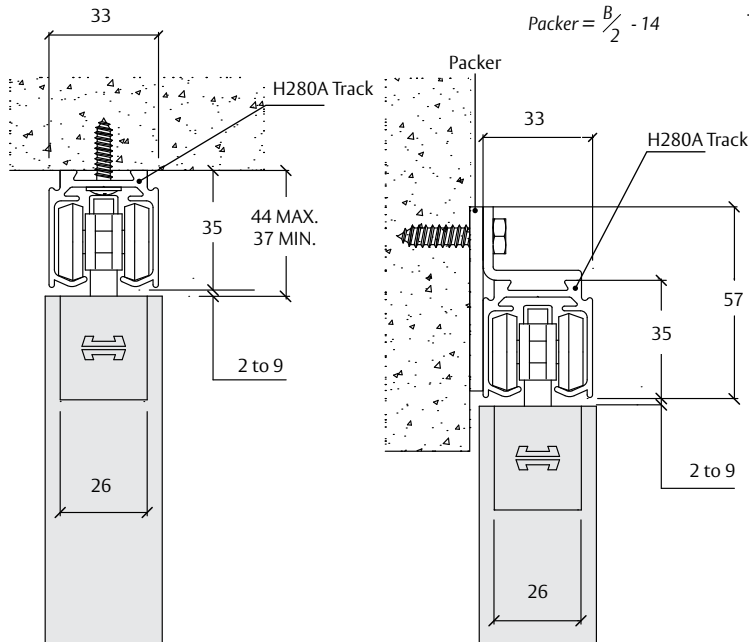

NOT TO SCALE

50 MAX.
34 MIN.

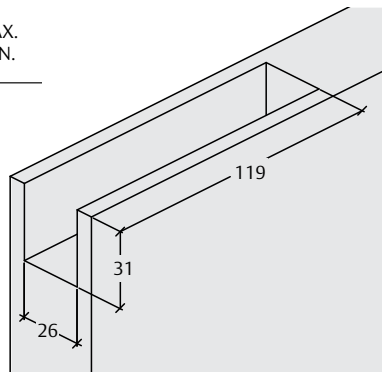

Cutout for Low Headroom Unit

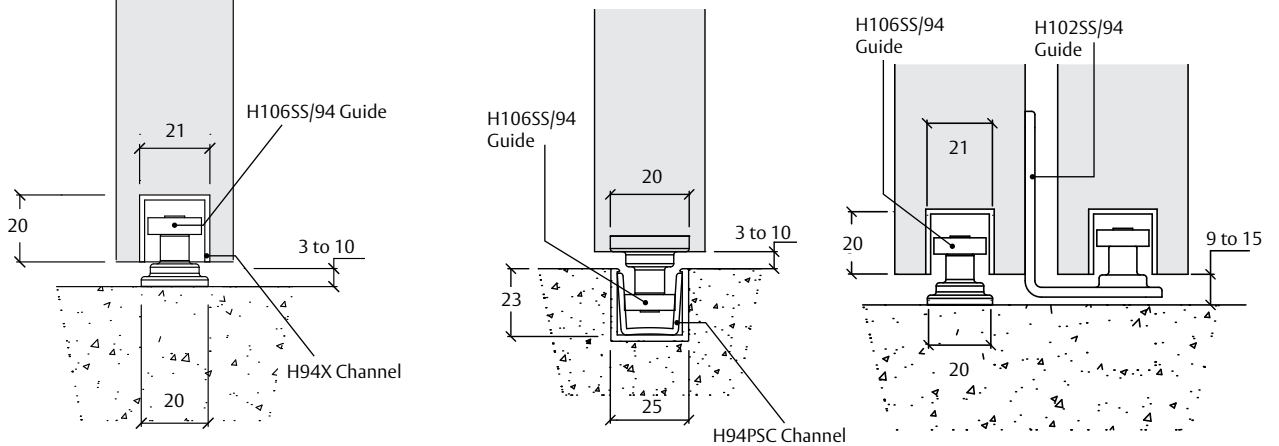

SOLTAIRE 120

For top hung sliding doors. Max 120kg each.

APPLICATION

- Manufactured from high grade 316 stainless steel with anodised aluminium track
- This reliable system is extremely durable and ideal for coastal applications, heavy use or areas requiring a high level of corrosion resistance
- Designed for interior and exterior doors up to 120kg
- Ideal for residential or commercial applications
- Designed to accommodate single or multiple panels on one or more tracks
- Hangers available for MDF, timber or metal doors
- The track can be soffit fixed or face fixed to give flexibility of installation

DOOR SPECIFICATION

Track System Soltaire120

For Individual Doors:

Max Door Weight 120kg
Door Thickness 19-48mm*
Max Panel Height 3000mm

* For doors thicker than 48mm, please contact our technical sales team for further information.

HARDWARE SPECIFICATION

Track **H120** Aluminium (2000, 3000, 4000 & 6000mm lengths)
H120A Anodised Aluminium (2000, 3000, 4000 & 6000mm lengths)
Soffit fix spacing 600mm centres (maximum)

Brush Strips **HBS10, HBS15, HBS20, HBS25** Available in black in 4 brush heights, by the metre

Brackets **H1/SS** Face fixed stainless steel
H5/SS Double run face fixed stainless steel
Starting 20mm from end of track fix at 600mm maximum centres.

Hangers (2 per door)* **H51/120/SS** Timber Doors – top fix – surface mounted
H52/120/SS MDF Doors – face fixing
H56/120/SS Metal Doors – angle frame fixing
H57/120/SS Timber Doors – concealed plate fixing

* Each panel must be rigid enough to be supported by only two hangers

Track Stop **HH4/SS** Anodised aluminium with rubber buffer

Guides **H101N** Nylon saw cut guide
H102SS/94 Timber doors - wall mounted and multiple run guide
H104P/89 Metal door - angle frame
H104PX/89 Metal door - box section
H105SS/94 Timber doors - face mounted guide
H106SS/94 Timber doors - concealed fixing with SS bearing

Channels **H89SS** Stainless steel (2000 & 3000mm length)
H94X Aluminium (2000, 3000, 4000 & 6000mm lengths)
H94 Brass (1500 & 3000mm lengths)
H94P Polypropylene (2000, 3000, 4000 & 6000mm lengths)
H94PSC Aluminium supporting channel and polypropylene (2000, 3000, 4000 & 6000mm lengths)

Accessories

Interlocking Seal **H59BZ/4800** Bronze anodised (4800mm to suit typical 2400mm door height)
H59CA/4800 Clear anodised aluminium (4800mm to suit typical 2400mm door height)
Drilled and countersunk. Includes brush seal.

Universal Telescopic **HUTEL/2** 2 Door kit non-handed
HUTEL/3 3 Door kit non-handed

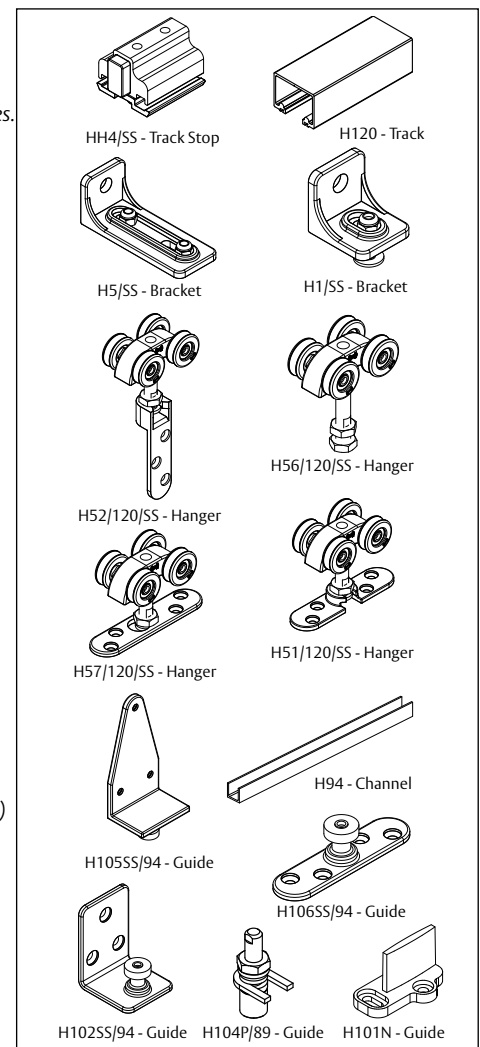

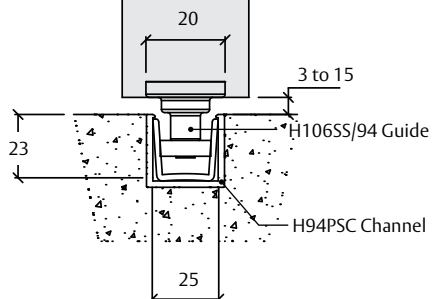
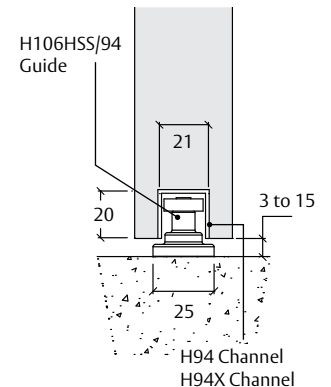
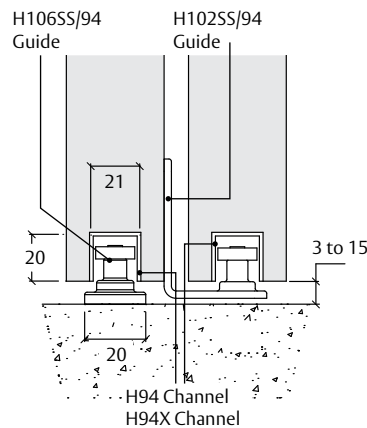
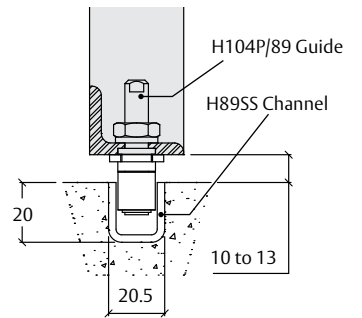
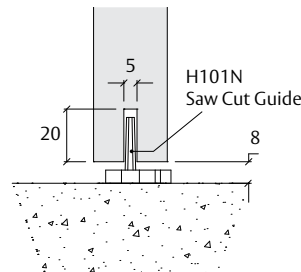
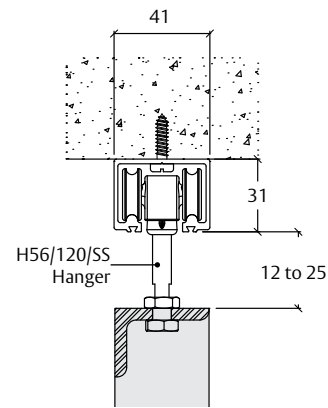
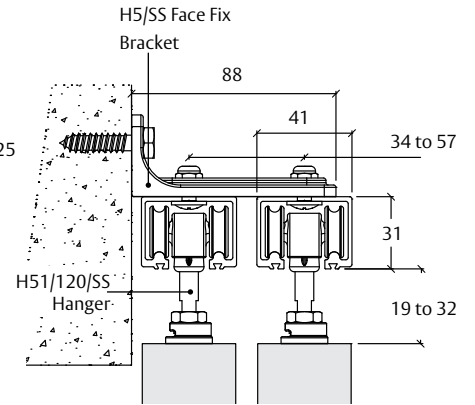
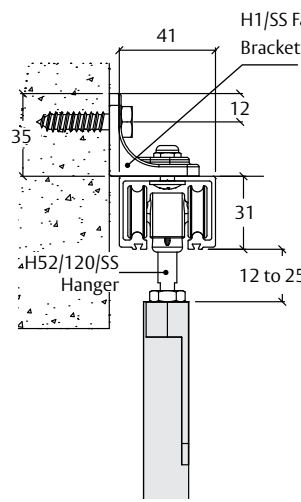
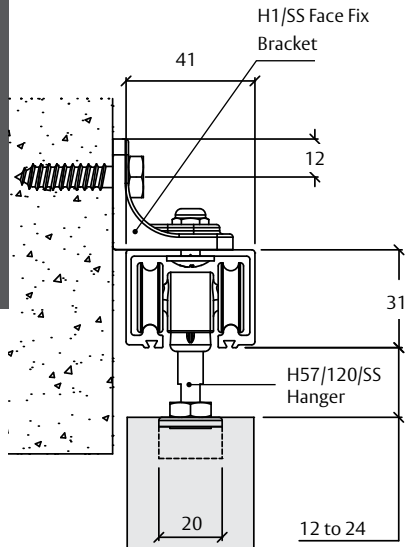

NOT TO SCALE

HENDERSON

SOLTAIRE LOW HEADROOM 120

For timber top hung sliding doors. Max 120kg.

APPLICATION

- Designed to create a modern minimalist finish with all parts concealed
- Can reduce the clearance between the track and the top of the door to 2mm
- Vertically adjustable sliding door kit for low or restricted headroom applications
- Used to maximise door height
- Engineered for easy installation and adjustment
- Designed to accommodate single or multiple panels on one or more tracks

DOOR SPECIFICATION

Track System **Low Headroom 120**

For Individual Door Leaves:

Max Door Weight	120kg
Door Thickness	35-48mm*
Max Door Height	2700mm

* For doors thicker than 48mm, please contact our technical sales team for further information.

STANDARD PACK

Pack comprises of 2x Low Headroom units, 2x end caps, 2x track stops, all screws and fitting instructions.

Pack No.	Application
HLH120	1 door pack

HARDWARE SPECIFICATION

Track	H120	Aluminium (2000, 3000, 4000 & 6000mm lengths)
	H120A	Anodised Aluminium (2000, 3000, 4000 & 6000mm lengths) Soffit fix spacing 600mm centres (maximum)
Brackets	H1/SS	Face fixed stainless steel
	H5/SS/120	Double face fixed stainless steel Starting 20mm from end of track fix at 600mm centres (maximum)
Track Stop	HH4/SS	Anodised aluminium with rubber buffer
Guides	H102N	Nylon saw cut guide
	H102SS/94	Timber doors - wall mounted and multiple run guide
	H105SS/94	Timber doors - face mounted guide
	H106SS/94	Timber doors - concealed fixing with SS bearing
Channels	H94X	Aluminium (2000, 3000, 4000 & 6000mm lengths)
	H94	Brass (1500 & 3000mm lengths)
	H94P	Polypropylene (2000, 3000, 4000 & 6000mm lengths)
	H94PSC	Aluminium supporting channel and polypropylene (2000, 3000, 4000 & 6000mm lengths)
Accessories	Interlocking Seal	
	H59BZ/4800	Bronze anodised (4800mm to suit typical 2400mm door height)
	H59CA/4800	Clear anodised aluminium (4800mm to suit typical 2400mm door height) Drilled and countersunk. Includes brush seal.

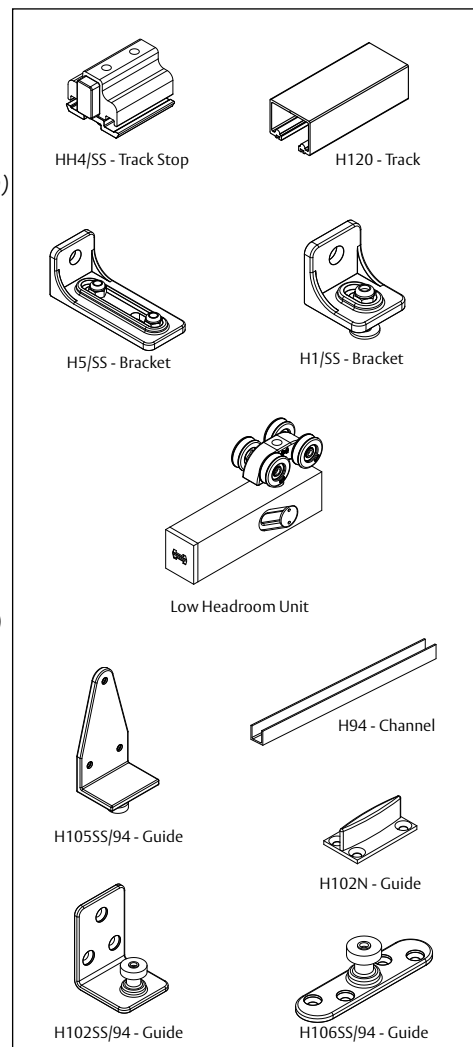

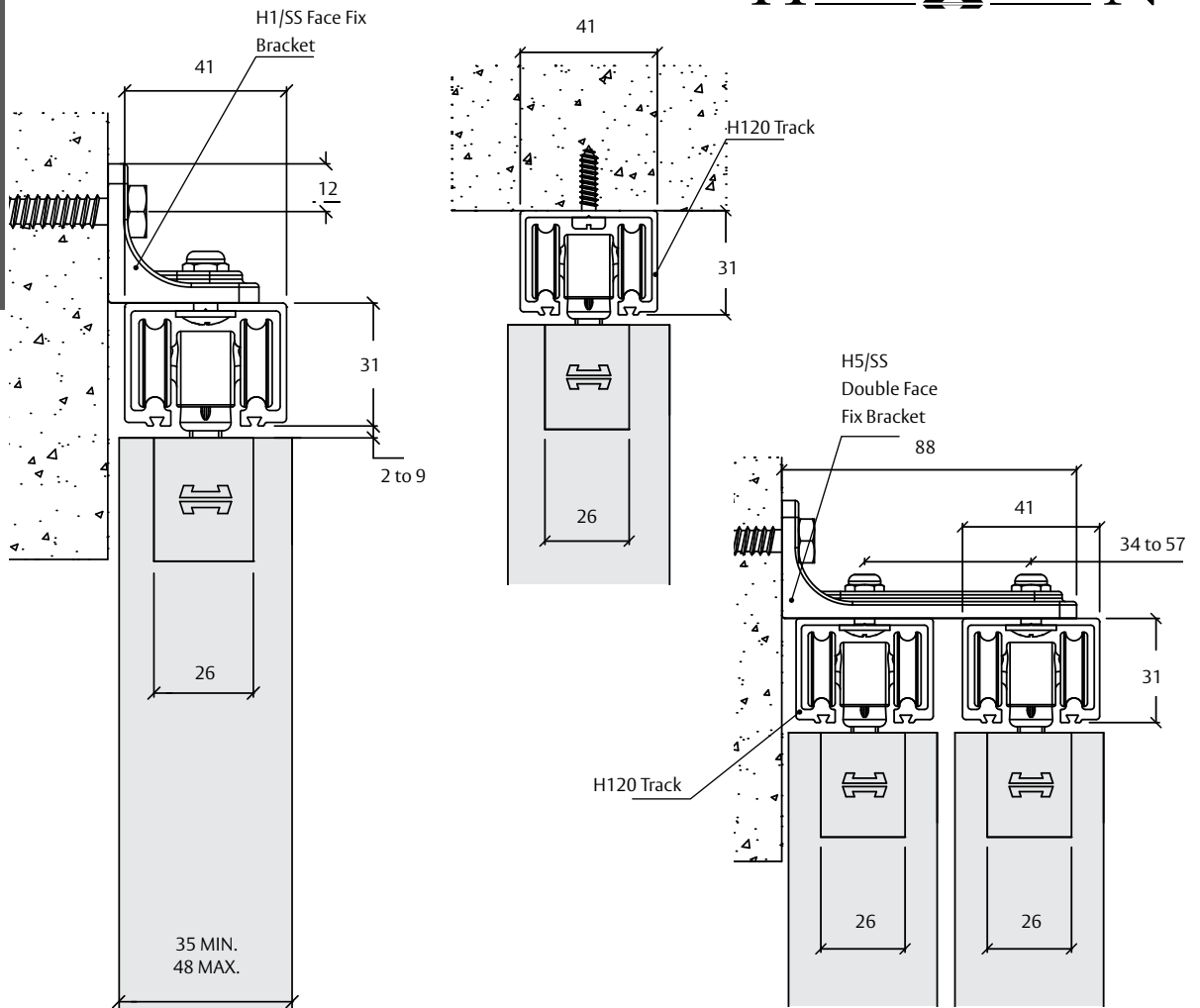

NOT TO SCALE

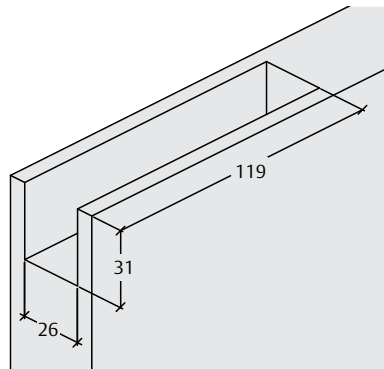

Cutout for Low Headroom Unit

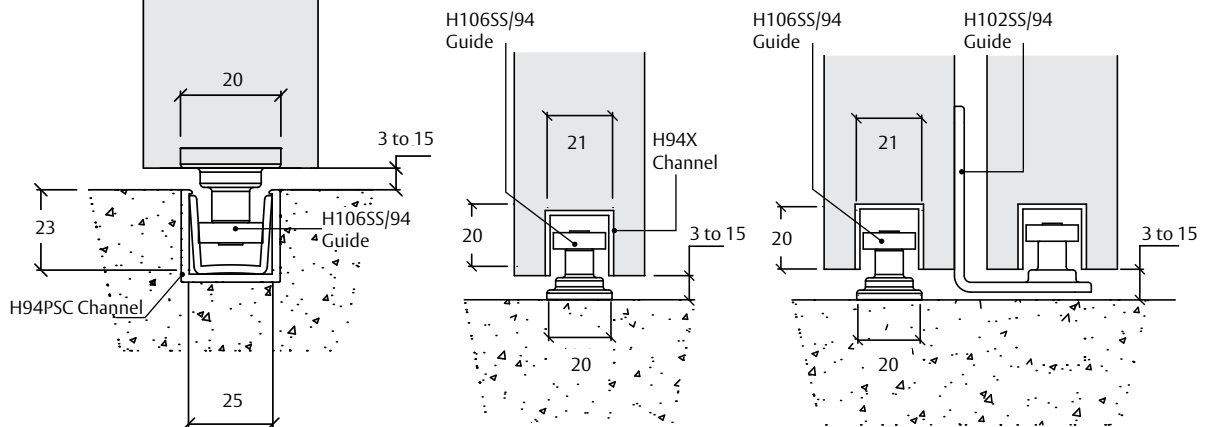
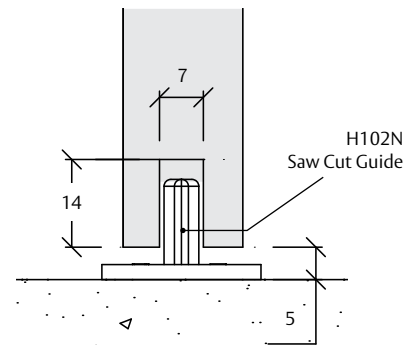

SIENNA

For sliding timber doors. Max. 120kg.

APPLICATION

- Elegant timber door system that creates a minimalist look
- 120kg system designed for doors 30-70mm thickness
- Rollers are engineered to run effortlessly along a brushed stainless steel track
- Stops are positioned to run on the track to limit door travel
- High quality stainless steel hangers and brackets

DOOR SPECIFICATION

Track System	Sienna
For Individual Doors:	
Max Door Weight	120kg
Min Door Width	700mm
Door Thickness	30-70mm
Max Door Height	2500mm

STANDARD SETS AND PACKS

Sets comprise of 2 hangers, 2 left & right door stops, one guide & 2 bar end caps

Pack No.	Hardware for
HSN120T	1 door

HARDWARE SPECIFICATION

Track	H25T	Stainless Steel (2000, 2500, 3000, 3500, 4000 & 5000mm lengths) Ø25mm tubular track, drilled and pre-assembled with correct number of brackets
Track Stop (2 per door)	H25/UDS	
Guides	H101/SS	Floor guide
End Cap	H25/EC	End cap for track

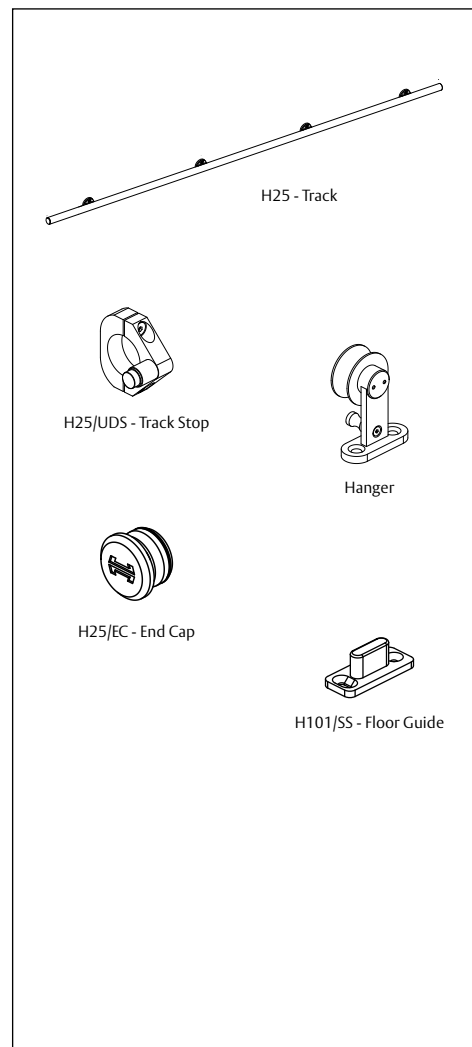

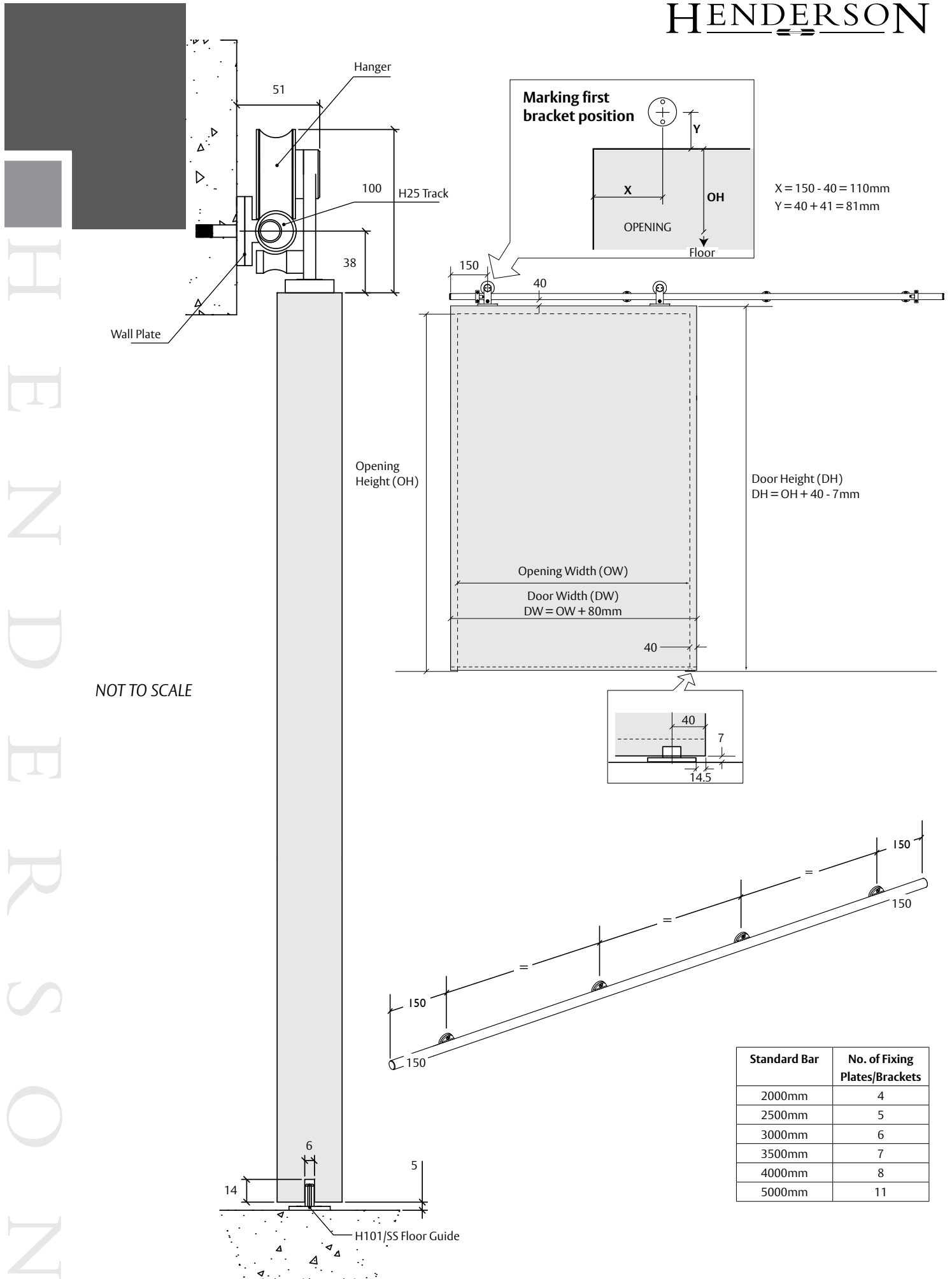

NOT TO SCALE

Standard Bar	No. of Fixing Plates/Brackets
2000mm	4
2500mm	5
3000mm	6
3500mm	7
4000mm	8
5000mm	11

SOLTAIRE 180

For top hung sliding doors. Max 180kg each.

APPLICATION

- Manufactured from high grade 316 stainless steel with anodised aluminium track
- This reliable system is extremely durable and ideal for coastal applications, heavy use or areas requiring a high level of corrosion resistance
- Designed for interior and exterior doors up to 180kg
- Ideal for residential or commercial applications
- Designed to accommodate single or multiple panels on one or more tracks
- Hangers available for timber or metal doors
- The track can be soffit fixed or face fixed to give flexibility of installation

DOOR SPECIFICATION

Track System Soltaire 180

For Individual Doors:

Max Door Weight 180kg
Door Thickness 35-48mm*
Max Panel Height 3000mm

* For doors thicker than 48mm, please contact our technical sales team for further information.

HARDWARE SPECIFICATION

Track **H180A** Anodised Aluminium (2000, 3000, 4000 & 6000mm lengths)
Soffit fix spacing 900mm centres (maximum)

Brush Strips **HBS10, HBS15, HBS20, HBS25** Available in black in 4 brush heights, by the metre (mm)

Brackets **H1/SS** Face fixed stainless steel
H5H/SS Double run face fixed stainless steel
Starting 20mm from end of track fix at 900mm maximum centres.

Hangers **H52/180/SS** Timber doors – angle plate fixing
H53/180/SS Timber doors – saddle plate fixing
H56/180/SS Metal doors – angle frame fixing
H56X/180/SS Metal doors – box frame fixing
H57/180/SS Timber doors – concealed plate fixing
H57/180/SS Metal doors – concealed plate fixing

* Each panel must be rigid enough to be supported by only two hangers

Track Stop **HH5/SS** Anodised aluminium with rubber buffer

Guides **H102SS/94** Timber doors - wall mounted and multiple run guide
H104PX/89 Metal door - box section
H104P/89 Metal door - angle frame
H105SS/94 Timber doors - face mounted guide
H106HSS/94 Timber doors - concealed fixing with SS bearing

Channels **H94X** Aluminium (2000, 3000, 4000 & 6000mm lengths)
H94 Brass (1500 & 3000mm lengths)
H89SS Stainless steel (2000 & 3000mm lengths)
H94P Polypropylene (2000, 3000, 4000 & 6000mm lengths)
H94PCS Aluminium supporting channel and polypropylene (2000, 3000, 4000 & 6000mm lengths)

Accessories

Interlocking Seal **H59BZ/4800** Bronze anodised (4800mm to suit typical 2400mm door height)
H59CA/4800 Clear anodised aluminium (4800mm to suit typical 2400mm door height)
Drilled and countersunk. Includes brush seal.

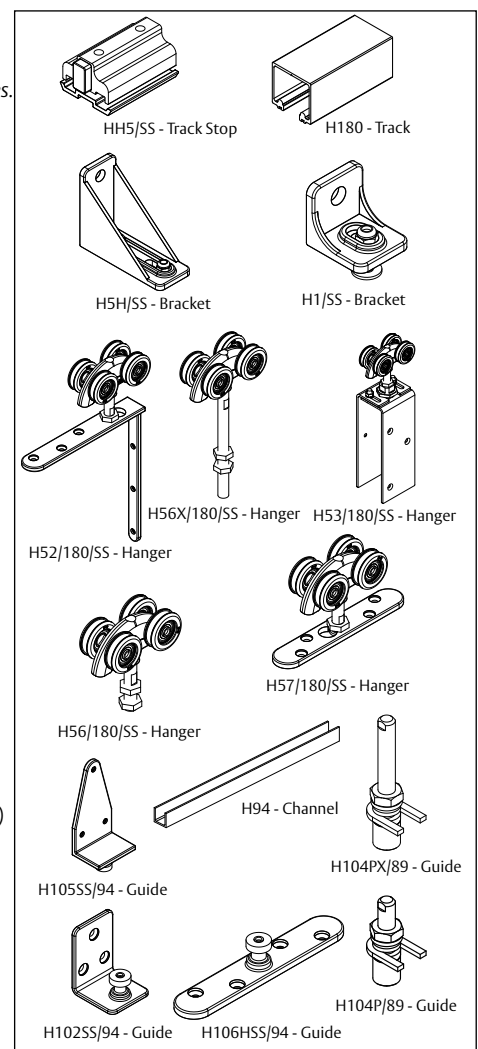

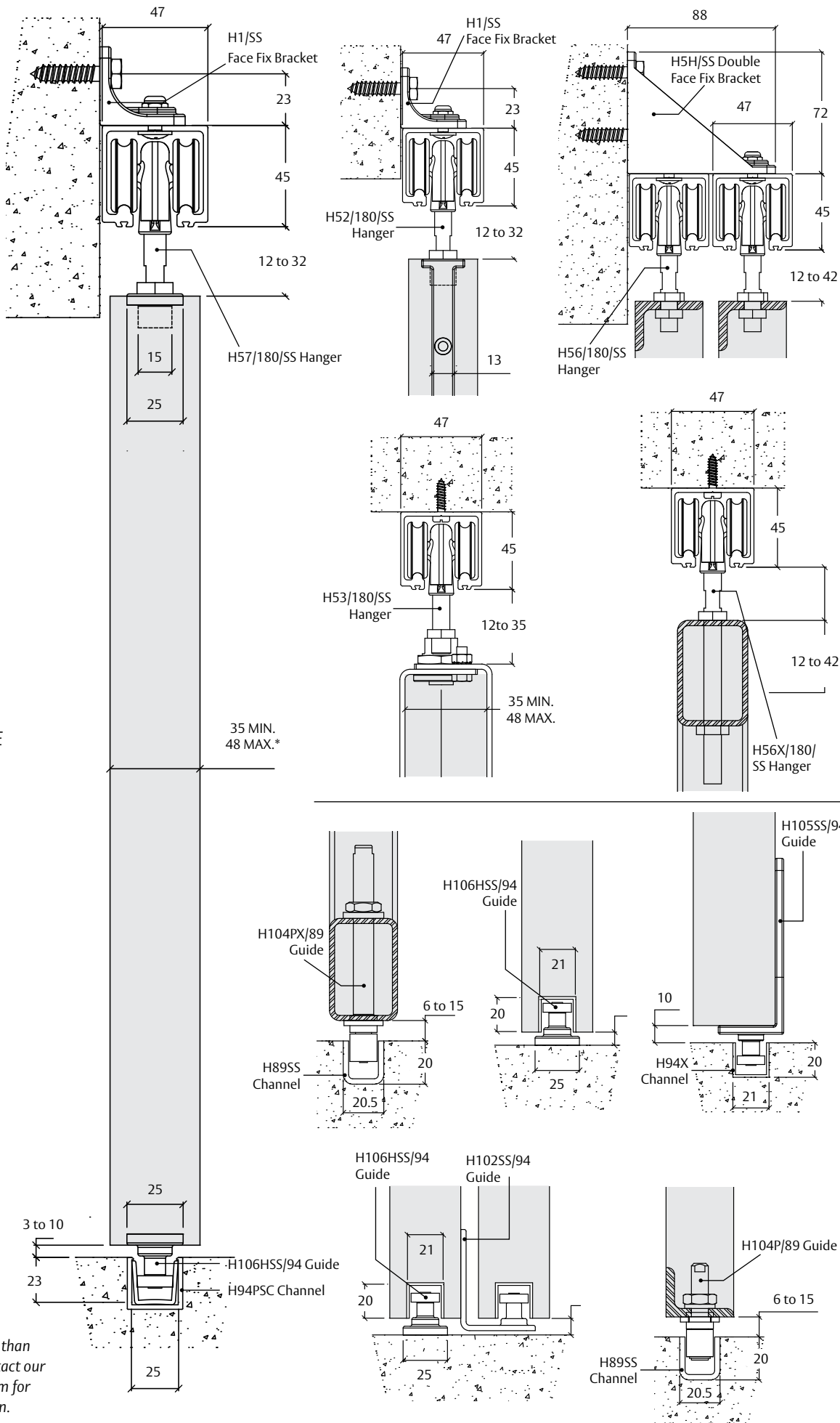

NOT TO SCALE

* For doors thicker than 48mm, please contact our technical sales team for further information.

HENDERSON

SOLTAIRE LOW HEADROOM 180

For timber top hung sliding doors. Max 180kg.

APPLICATION

- Designed to create a modern minimalist finish with all parts concealed
- Can reduce the clearance between the track and the top of the door to 2mm
- Vertically adjustable sliding door kit for low or restricted headroom applications
- Used to maximise door height
- Engineered for easy installation and adjustment
- Designed to accommodate single or multiple panels on one or more tracks

DOOR SPECIFICATION

Track System **Low Headroom 180**

For Individual Door Leaves:

Max Door Weight	180kg
Max Door Width	3300mm
Door Thickness	35-48mm*
Max Door Height	2700mm

* For doors thicker than 48mm, please contact our technical sales team for further information.

STANDARD PACK

Pack comprises of 2x Low Headroom units, 2x end caps, 2x track stops, all screws and fitting instructions.

Pack No.	Application
HLH180	1 door pack

HARDWARE SPECIFICATION

Track	H180A	Anodised Aluminium (2000, 3000, 4000 & 6000mm lengths) Soffit fix spacing 900mm centres (maximum)
Brackets	H1/SS	Face fixed stainless steel
	H5H/SS	Double face fixed stainless steel (heavy) Starting 20mm from each end of track fix at 900mm centres (max.)
Track Stop	HH5/SS	Anodised aluminium with rubber buffer
Guides	H102SS/94	Timber doors - wall mounted and multiple run guide
	H105SS/94	Timber doors - face mounted guide
	H106HSS/94	Timber doors - concealed fixing with SS bearing
Channels	H94X	Aluminium (2000, 3000, 4000 & 6000mm lengths)
	H94	Brass (1500 & 3000mm lengths)
	H94P	Polypropylene (2000, 3000, 4000 & 6000mm lengths)
	H94PSC	Aluminium supporting channel and polypropylene (2000, 3000, 4000 & 6000mm lengths)
Accessories	H59BZ/4800	Bronze anodised (4800mm to suit typical 2400mm door height)
	H59CA/4800	Clear anodised aluminium (4800mm to suit typical 2400mm door height) Drilled and countersunk. Includes brush seal.

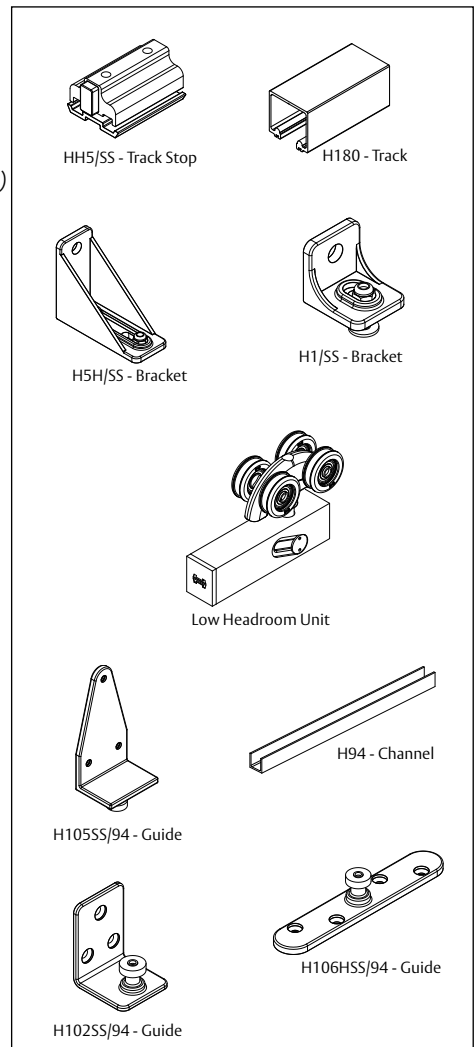

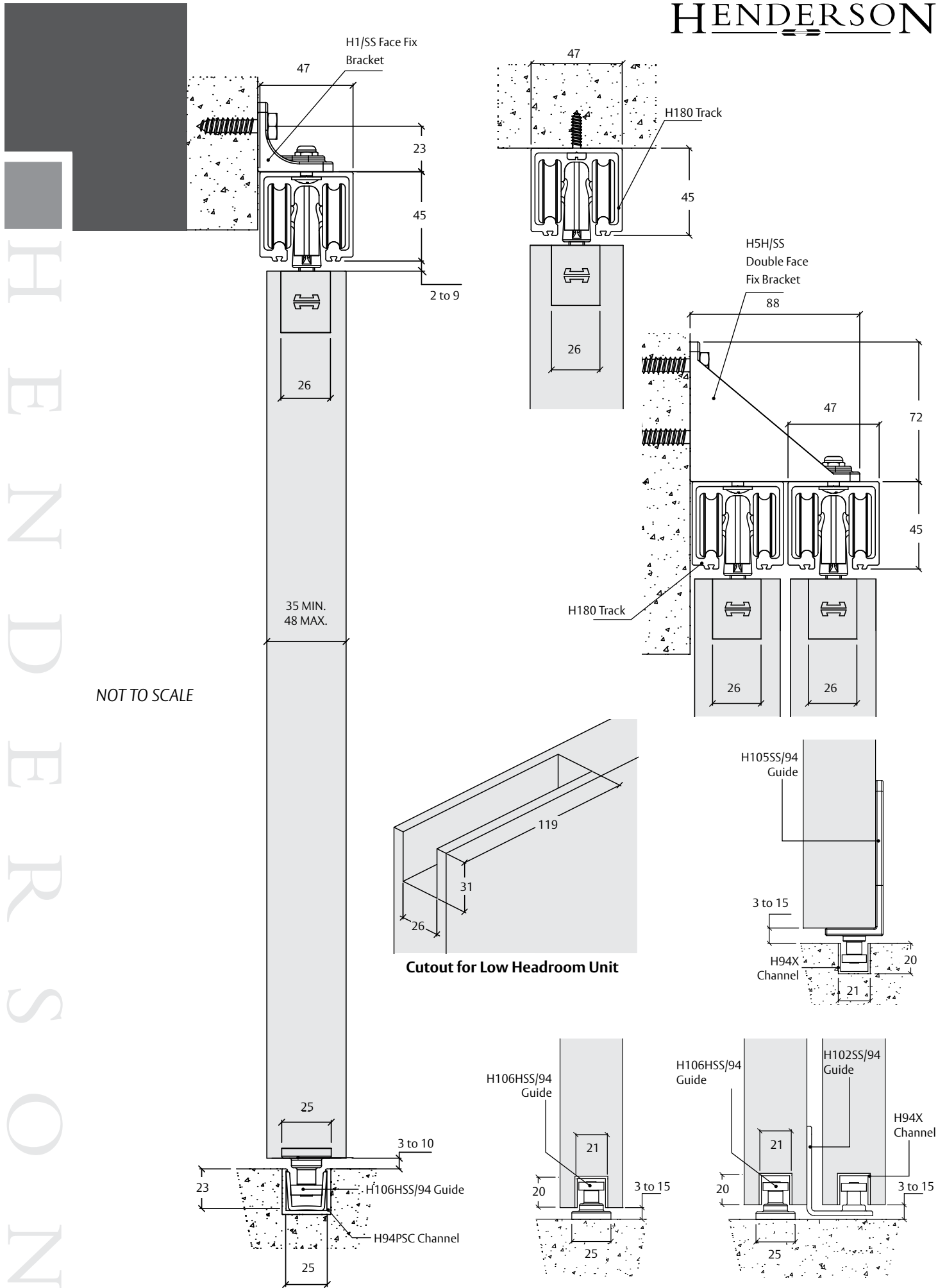

NOT TO SCALE

HENDERSON

PACER

For top hung sliding timber and metal doors. Max. 200kg.

APPLICATION

- Ideally suited to shop fronts, offices and other stylish interiors
- Designed for straight sliding doors in timber, aluminium or metal

DOOR SPECIFICATION

Track System	Pacer
For Individual Doors:	
Max Door Weight	200kg
Max Door Width	2000mm
Door Thickness	35-50mm*
Max Door Height	3000mm

* For doors thicker than 50mm, please contact our technical sales team for further information.

HARDWARE SPECIFICATION

Track	H600	Aluminium (2000, 3000, 4000 & 6000mm lengths)
Brackets	H1B	Face fixed
	H1BX	Joining and end bracket
Hangers	H52B	Timber Doors – angle plate fixing
(2 per door)	H56B	Metal Doors – angle frame
	H56BX	Metal Doors – box frame
	H57B	Timber/Metal Doors – concealed fixing
Clip Stop	H601P	Adjustable retaining stop
Guides	H102SS/94	Timber doors - wall mounted and multiple run guide
	H104PX/89	Metal door - box section
	H104P/89	Metal door - angle frame
	H105SS/94	Timber doors - face mounted guide
	H106HSS/94	Timber doors - concealed fixing with SS bearing
Channels	H94X	Aluminium (2000, 3000, 4000 & 6000mm lengths)
	H94	Brass (1500 & 3000mm lengths)
	H89SS	Stainless steel (2000 & 3000mm lengths)
	H94P	Polypropylene (2000, 3000, 4000 & 6000mm lengths)
	H94PSC	Aluminium supporting channel and polypropylene (2000, 3000, 4000 & 6000mm lengths)
Accessories		
Fascia	HF160	Anodised aluminium for soffit fixed applications (2000, 2500, 3000, 3500, 4000 & 6000mm lengths)
	HF200	Anodised aluminium with standard return for face fixed applications (2000, 2500, 3000, 3500, 4000 & 6000mm lengths)

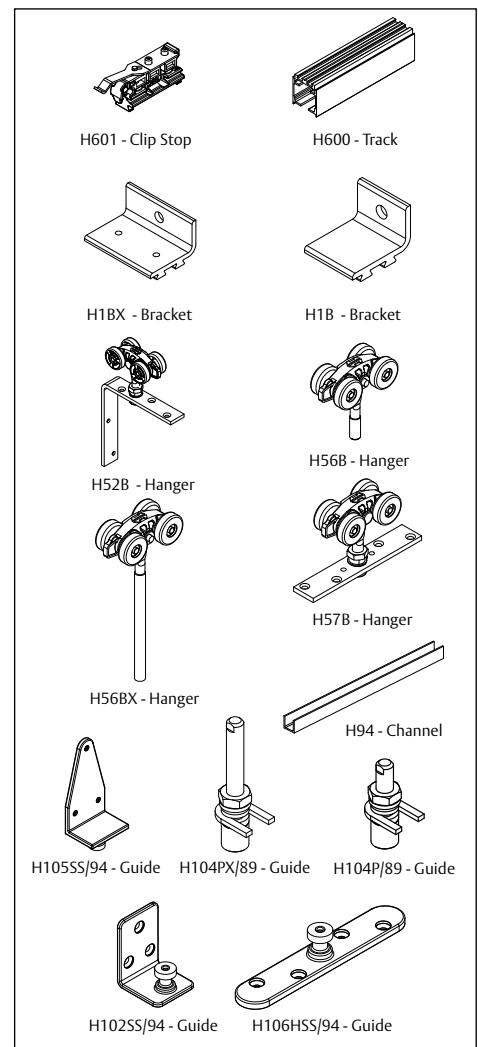

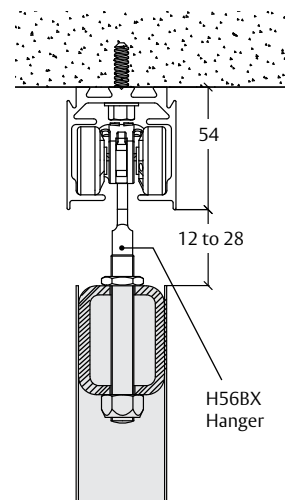
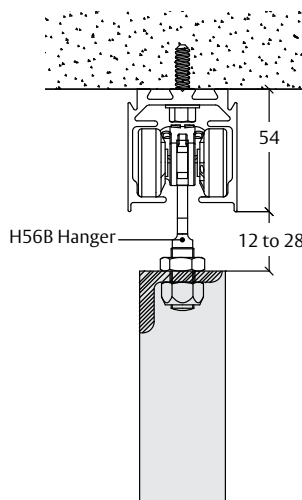
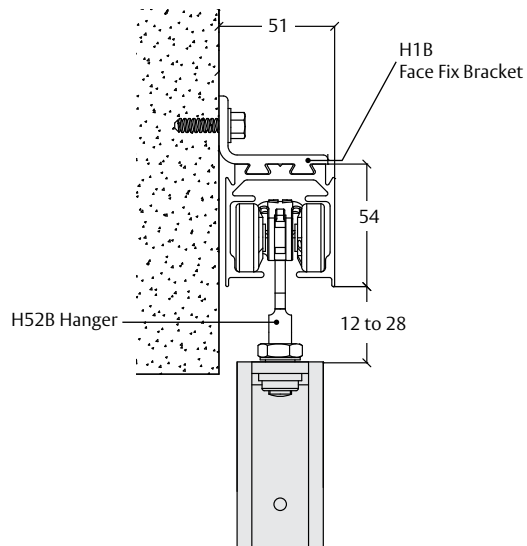
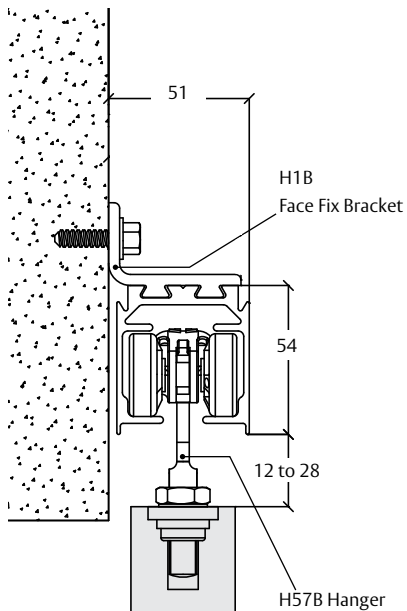

NOT TO SCALE

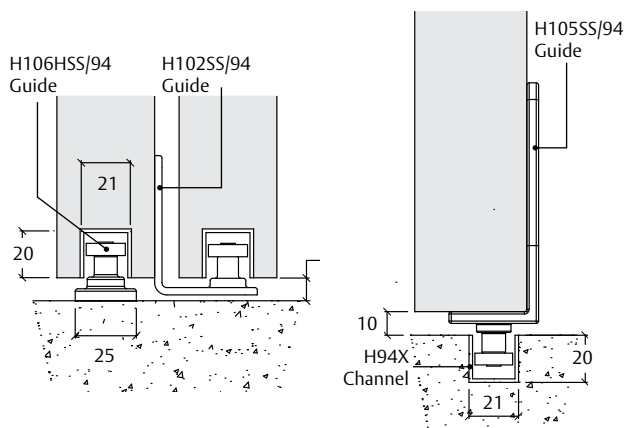
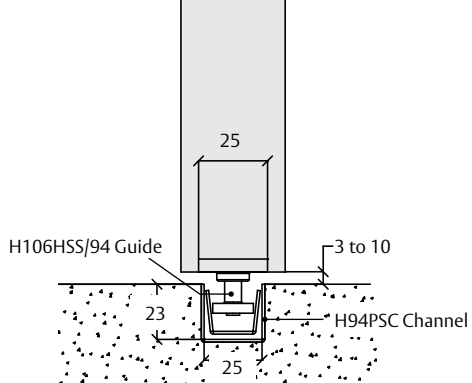
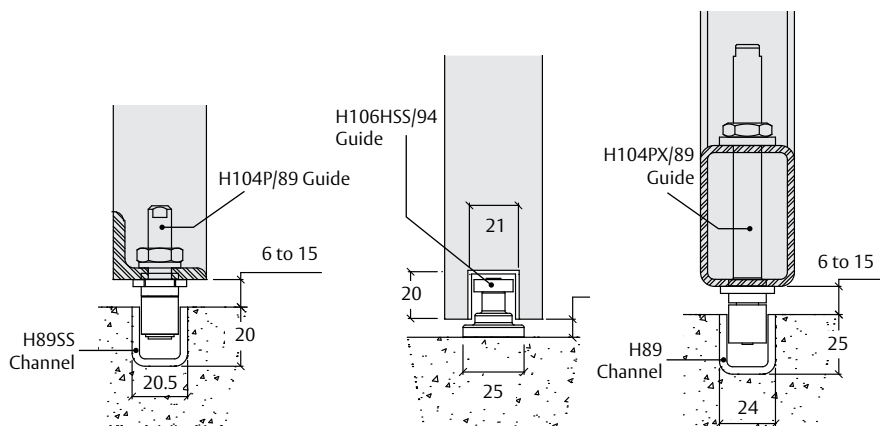

HENDERSON

ISSUE 1-0515

SOLTAIRE 250

For top hung sliding doors. Max 250kg each.

APPLICATION

- Manufactured from high grade 316 stainless steel with anodised aluminium track
- This reliable system is extremely durable and ideal for coastal applications, heavy use or areas requiring a high level of corrosion resistance
- Designed for interior and exterior doors up to 250kg
- Ideal for residential or commercial applications
- Designed to accommodate single or multiple panels on one or more tracks
- Hangers available for timber or metal doors
- The track can be soffit fixed or face fixed to give flexibility of installation

DOOR SPECIFICATION

Track System Soltaire 250

For Individual Doors:

Max Door Weight 250kg
Door Thickness 35-48mm*
Max Panel Height 3300mm

* For doors thicker than 48mm, please contact our technical sales team for further information.

HARDWARE SPECIFICATION

Track **H250A** Anodised Aluminium (2000, 3000, 4000 & 6000mm lengths)
Soffit fix spacing 900mm centres (maximum)

Brush Strips **HBS10, HBS15, HBS20, HBS25** Available in black in 4 brush heights, by the metre (mm)

Brackets **H1/SS** Face fixed stainless steel
H5H/SS Double face fixed stainless steel (heavy)
Starting 20mm from end of track fix at 900mm maximum centres.

Hangers (2 per door)* **H52/250/SS** Timber doors – angle plate fixing
H53/250/SS Timber doors – saddle plate fixing
H56/250/SS Metal doors – angle frame fixing
H56X/250/SS Metal doors – box frame fixing
H57/250/SS Timber doors – concealed plate fixing
H57/250/SS Metal doors – concealed plate fixing

* Each panel must be rigid enough to be supported by only two hangers

Track Stop **HH5/SS** Anodised aluminium with rubber buffer

Guides **H102SS/94** Timber doors - wall mounted and multiple run guide
H104PX/89 Metal door - box section
H104P/89 Metal door - angle frame
H105SS/94 Timber doors - face mounted guide
H106HSS/94 Timber doors - concealed fixing with SS bearing

Channels **H94X** Aluminium (2000, 3000, 4000 & 6000mm lengths)
H94 Brass (1500 & 3000mm lengths)
H89SS Stainless steel (2000 & 3000mm lengths)
H94P Polypropylene (2000, 3000, 4000 & 6000mm lengths)
H94PSC Aluminium supporting channel and polypropylene (2000, 3000, 4000 & 6000mm lengths)

Accessories

Interlocking Seal **H59BZ/4800** Bronze anodised (4800mm to suit typical 2400mm door height)
H59CA/4800 Clear anodised aluminium (4800mm to suit typical 2400mm door height)
Drilled and countersunk. Includes brush seal.

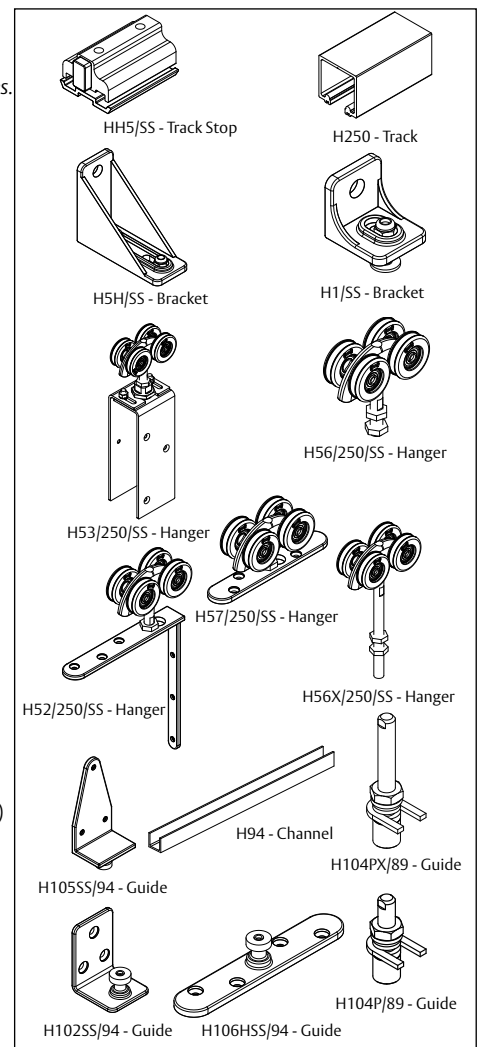

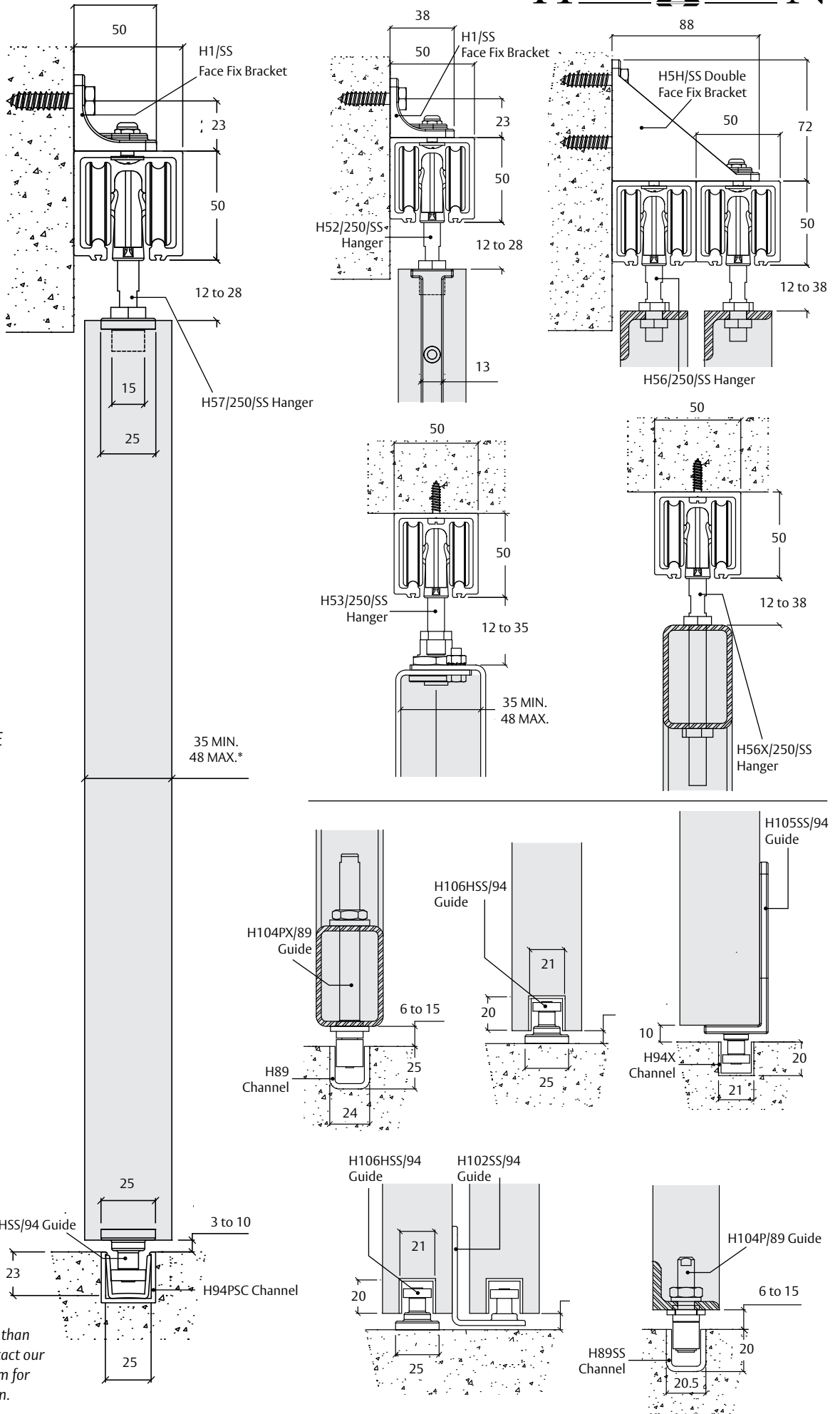

NOT TO SCALE

35 MIN.
48 MAX.*

* For doors thicker than 48mm, please contact our technical sales team for further information.

SOLTAIRE LOW HEADROOM 250

For timber top hung sliding doors. Max 250kg.

APPLICATION

- Designed to create a modern minimalist finish with all parts concealed
- Can reduce the clearance between the track and the top of the door to 2mm
- Vertically adjustable sliding door kit for low or restricted headroom applications
- Used to maximise door height
- Engineered for easy installation and adjustment
- Designed to accommodate single or multiple panels on one or more tracks

DOOR SPECIFICATION

Track System **Low Headroom 250**

For Individual Door Leaves:

Max Door Weight	250kg
Door Thickness	35-48mm*
Max Door Height	3300mm

* For doors thicker than 48mm, please contact our technical sales team for further information.

STANDARD PACK

Pack comprises of 2x Low Headroom units, 2x end caps, 2x track stops, all screws and fitting instructions.

Pack No.	Application
HLH250	1 door pack

HARDWARE SPECIFICATION

Track	H250A	Anodised Aluminium (2000, 3000, 4000 & 6000mm lengths) Soffit fix spacing 900mm centres (maximum)
Brackets	H1/SS	Face fixed stainless steel
	H5H/SS	Double face fixed stainless steel (heavy) Starting 20mm from each end of track fix at 900mm centres (max.)
Track Stop	HH5/SS	Anodised aluminium with rubber buffer
Guides	H102SS/94	Timber doors - wall mounted and multiple run guide
	H105SS/94	Timber doors - face mounted guide
	H106HSS/94	Timber doors - concealed fixing with SS bearing
Channels	H94X	Aluminium (2000, 3000, 4000 & 6000mm lengths)
	H94	Brass (1500 & 3000mm lengths)
	H94P	Polypropylene (2000, 3000, 4000 & 6000mm lengths)
	H94PSC	Aluminium supporting channel and polypropylene (2000, 3000, 4000 & 6000mm lengths)
Accessories	H59BZ/4800	Bronze anodised (4800mm to suit typical 2400mm door height)
	H59CA/4800	Clear anodised aluminium (4800mm to suit typical 2400mm door height) Drilled and countersunk. Includes brush seal.

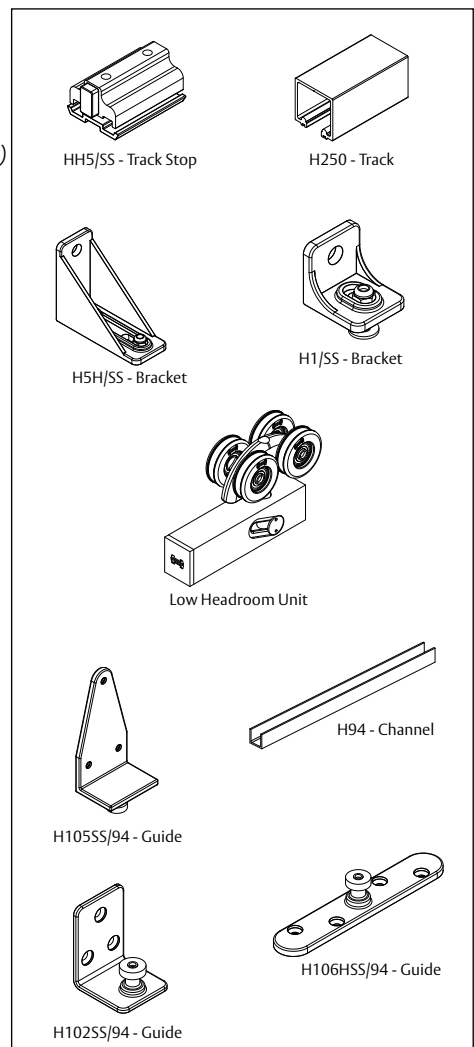

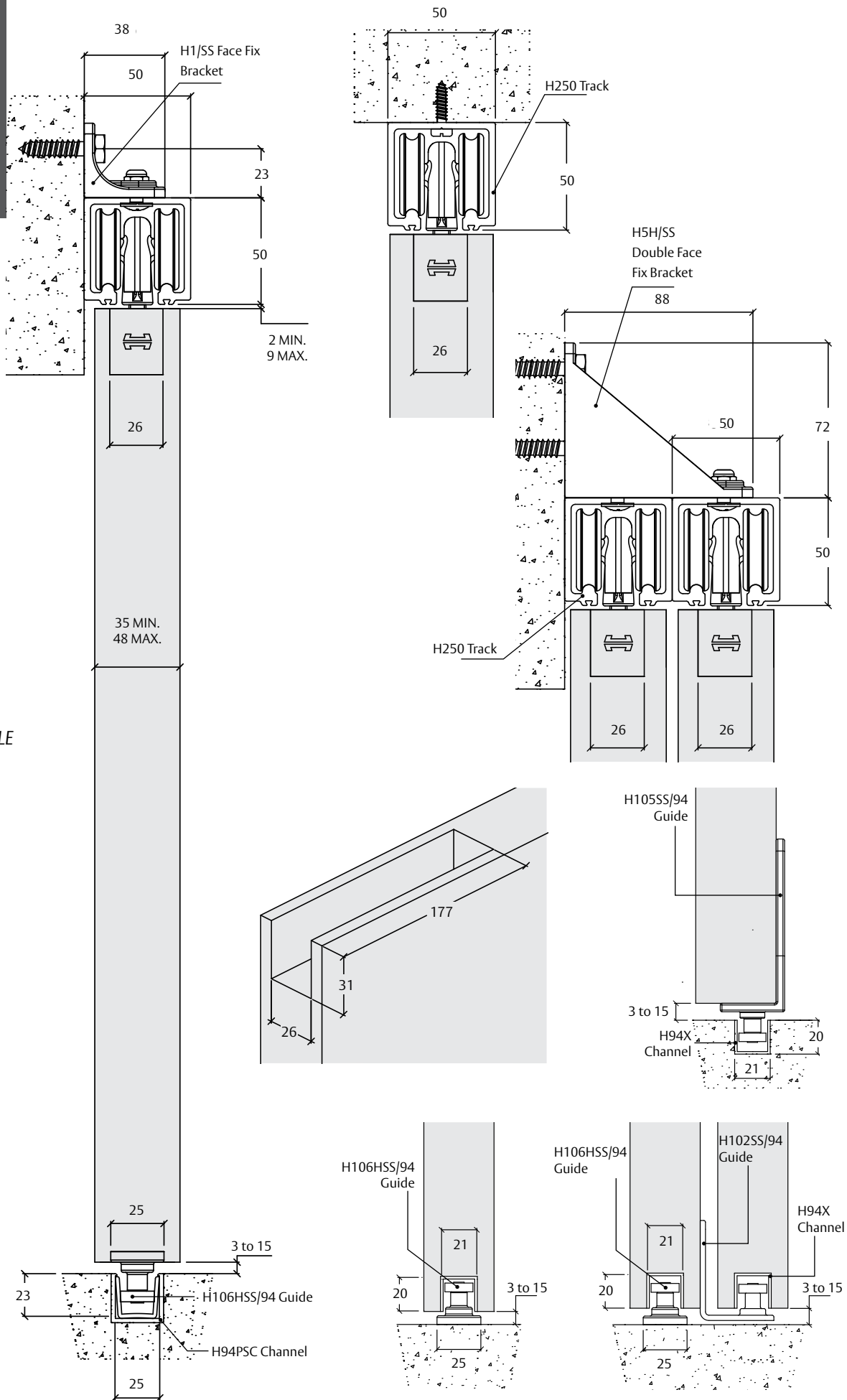

NOT TO SCALE

HENDERSON

FLEXIROL 500

For top hung sliding timber and metal doors. Max. 500kg.

APPLICATION

- Ideally suited to hotels, conference centres, shop fronts, showrooms or any site requiring high performance and an attractive finish
- Designed for straight sliding doors in timber, metal or glass

DOOR SPECIFICATION

Track System	Flexirol 500
For Individual Doors:	
Max Door Weight	500kg. 2 Hangers per leaf.
Max Door Width	6000mm
Door Thickness	40-100mm*
Max Door Height	6000mm

* For doors thicker than 100mm, please contact our technical sales team for further information.

HARDWARE SPECIFICATION

Track	H550	Anodised Aluminium (2000, 3000, 4000 & 6000mm lengths) For full range of finishes please contact our Technical Sales Team.
Brackets	H1A/550 H3S/550	Face fixed Soffit fixed
Hangers	H556	Metal doors - angle frame fixing
(2 per door)*	H556/52	Timber doors - angle plate fixing
	H556/57	Timber doors - concealed plate fixing
* Each panel must be rigid enough to be supported by only two hangers		
Track Stop	H3/301	Flexirol track stop
Guides	H104N/94 H104NX/94 H106HSS/94	Metal doors - angle frame fixing Metal doors - box frame fixing Timber doors - concealed fixing
Channels	H94X H94P H94PSC	Aluminium (2000, 3000, 4000 & 6000mm lengths) Polypropylene (2000, 3000, 4000 & 6000mm lengths) Aluminium supporting channel and polypropylene (2000, 3000, 4000 & 6000mm lengths)

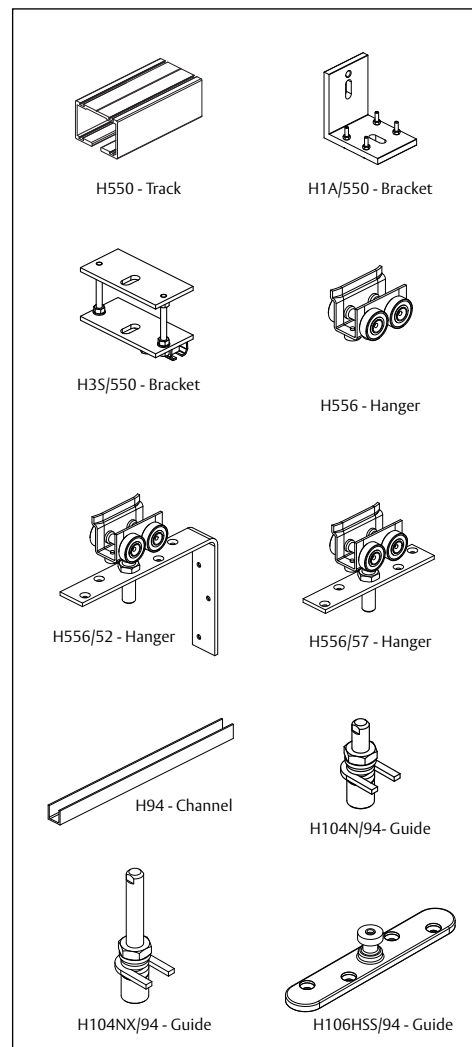



HENDERSON

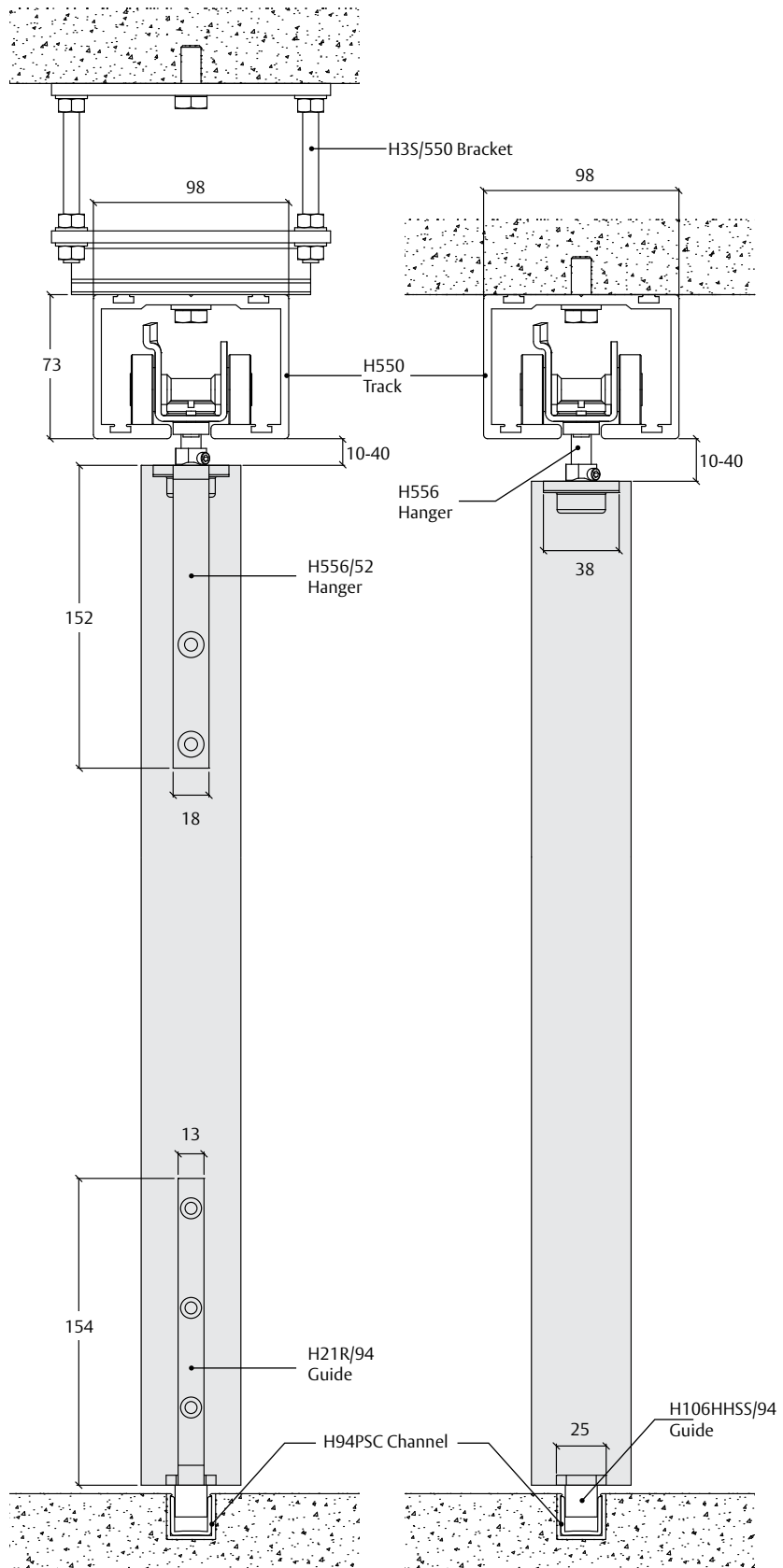
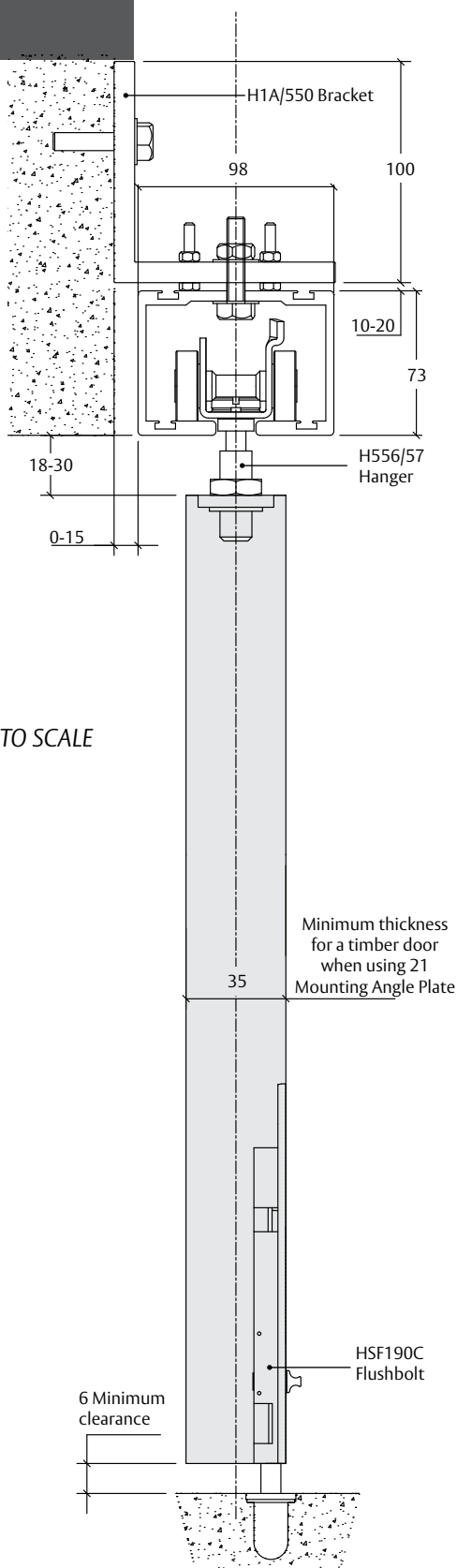

NOT TO SCALE

Minimum thickness
for a timber door
when using 21
Mounting Angle Plate

6 Minimum
clearance

HSF190C
Flushbolt

H21R/94
Guide

H94PSC Channel

H106HHSS/94
Guide

ISSUE 1-0515

ASSA ABLOY New Zealand Ltd. PO Box 100407, North Shore, Auckland 0745 • 6 Armstrong Road, Albany, Auckland 0632, New Zealand
Within New Zealand: Tel 09 448 9188 Fax 415 7889 www.assaabloy.co.nz • Online Catalogue: www.assaabloycatalogue.co.nz

STRAIGHT SLIDING 290

For timber or metal top hung sliding doors. Max 150 or 200kg

APPLICATION

- Designed for commercial and industrial applications
- Designed to accommodate single or multiple panels on one or more tracks
- Versatile range of hanger, track, bracket and guide options, allows the 290 system a wide range of applications
- Where doors are fitted externally, a canopy is recommended

DOOR SPECIFICATION

Track System	290
For Individual Doors:	
Max Door Wt Nylon Hanger	150kg
Max Door Wt Steel Hanger	200kg
Door Thickness	35-48mm
Max Door Height	3000mm

HARDWARE SPECIFICATION

Track **H290** Galvanised Steel (2000, 2500, 3000, 4000 & 6000mm lengths)
Fix spacing at 900mm centres (maximum)

Brackets **Aluminium** **Steel (Zinc plated)**

H1A/290	H1/290S	Face fix, single track
H3A/290	-	Soffit fix, single track
H4A/290	-	Soffit fix (in line), single track
-	H4R/290S	Soffit fix (adjustable), single track
H5/290	-	Face fix, double track
H9A/290	-	Face fix (low headroom), single track

For closed and jointing bracket options please contact our Technical Sales Team.

Hangers **150kg** **200kg**
(2 per door)*

H52K/N	H52K/S200	Timberdoors - angle plate fixing
H53K/N	H53K/S200	Timber doors - apron fixing
H57K/N	H57K/S200	Timber doors - concealed fixing
H56K/N	H56K/S200	Metal doors - angle frame
H56KX/N	H56KX/S200	Metal doors - box frame
H57K/N	H57K/S200	Metal doors - concealed plate

- All hangers suffixed 'N' have silent running nylon wheels and 'S' have steel wheels.
- Nylon wheeled hangers should not be used on installations involving temperatures exceeding 80°C

* Each panel must be rigid enough to be supported by only two hangers

Guides

H31D	Wall guide, double
H31S	Wall guide, single
H104P/89	Metal doors – angle frame
H104PX/89	Metal doors – box frame
H105R/89	Timber doors
H106R/94	Timber doors – concealed fixing
H126	Ground stay roller

Channels

H89	Galvanised steel (2000, 3000 & 4000mm lengths)
H94X	Aluminium (2000, 3000, 4000 & 6000mm lengths)
H94	Brass (1500 & 3000mm lengths)

Pre-drilled and countersunk for wood or lugging into concrete.

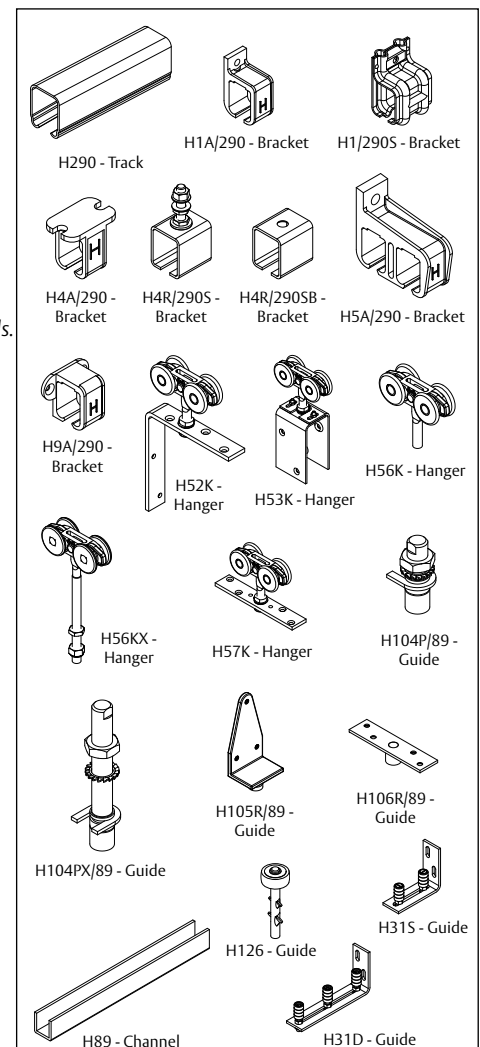

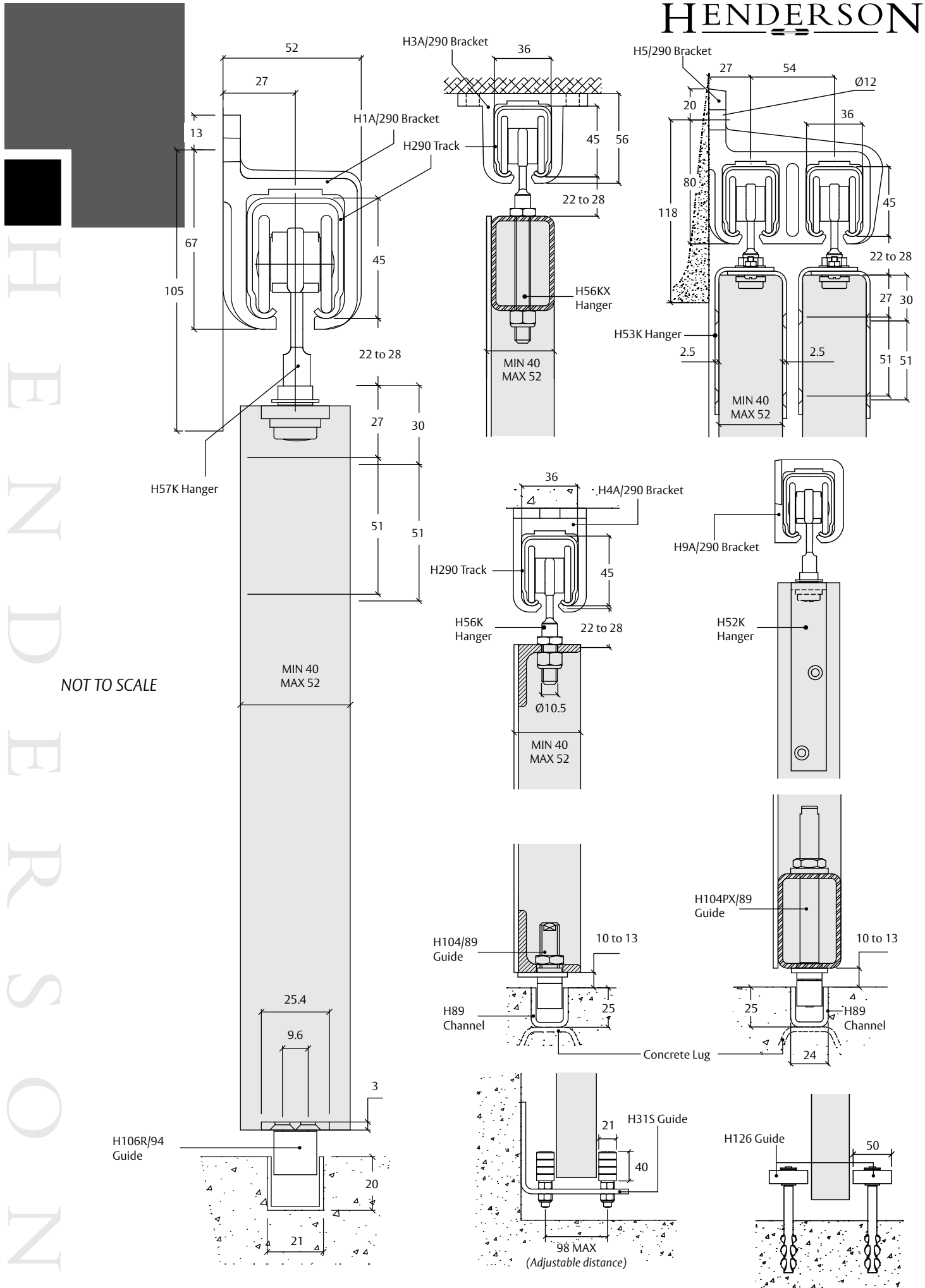

HENDERSON

STRAIGHT SLIDING 301

For timber or metal top hung sliding doors. Max 300, 400 or 450kg

APPLICATION

- Designed for commercial, industrial and agricultural applications
- Designed to accommodate single or multiple panels on one or more tracks
- Versatile range of hanger, track, bracket and guide options, allows the 301 system to be used in a wide range of applications
- Where doors are fitted externally, a canopy is recommended
- Suitable for Fire Resistant applications

DOOR SPECIFICATION

Track System	301	301H
For Individual Doors:		
Max Door Wt Nylon Hanger	400kg	450kg
Max Door Wt Steel Hanger	300kg	360kg
Door Thickness	43-57mm*	43-57mm*
Max Door Height	3600mm	4200mm

* For doors outside the recommended door thickness, please contact our technical sales team for further information.

HARDWARE SPECIFICATION

Track **H301 or H301H** Galvanised Steel (2000, 2500, 3000, 4000 & 6000mm lengths)
Fix spacing at 900mm centres (maximum)

Brackets	Aluminium	Steel (Zinc plated)
H1A/301		H1/301S Face fix, single track
H3A/301		H3/301S Soffit fix, single track
H4A/301		H4/301S Soffit fix (in line), single track
-		H4R/301S Soffit fix (adjustable), single track
H5/301	-	Face fix, double track
H6/301	-	Soffit fix, double track
-	H7/301S	Face fix, triple track
-	H8/301S	Soffit fix, triple track
-	H9/301S	Face fix (low headroom), single track

For closed and jointing bracket option please contact our Technical Sales Team.

Hangers (2 per door)*	Steel wheels	Nylon wheels
H52A/S		H52A/N Timberdoors - angle plate fixing
H53A/S		H53A/N Timber doors - apron fixing
H56A/S		H56A/N Metal doors - angle frame
H56AX/S		H56AX/N Metal doors - box frame
H57A/S		H57A/N Timber/metal doors - concealed plate

- All hangers suffixed 'N' have silent running nylon wheels and 'S' have steel wheels.
- Nylon wheeled hangers should not be used on installations involving temperatures exceeding 80°C

* Each panel must be rigid enough to be supported by only two hangers

Guides	H31D	Wall guide, double
	H31S	Wall guide, single
	H102/97	Timber doors
	H104P/97	Metal doors – angle frame
	H104PX/97	Metal doors – box frame
	H106R/97	Timber doors – concealed fixing
	H126H	Ground stay roller
	H128	Shoe guide

All steel parts are electro zinc-plated.

Channels	H97	Galvanised steel (1800, 2000, 2500, 3000, 4000 & 6000mm lengths) Pre-drilled for lugging into concrete and for use in drainage funnel.
----------	-----	---

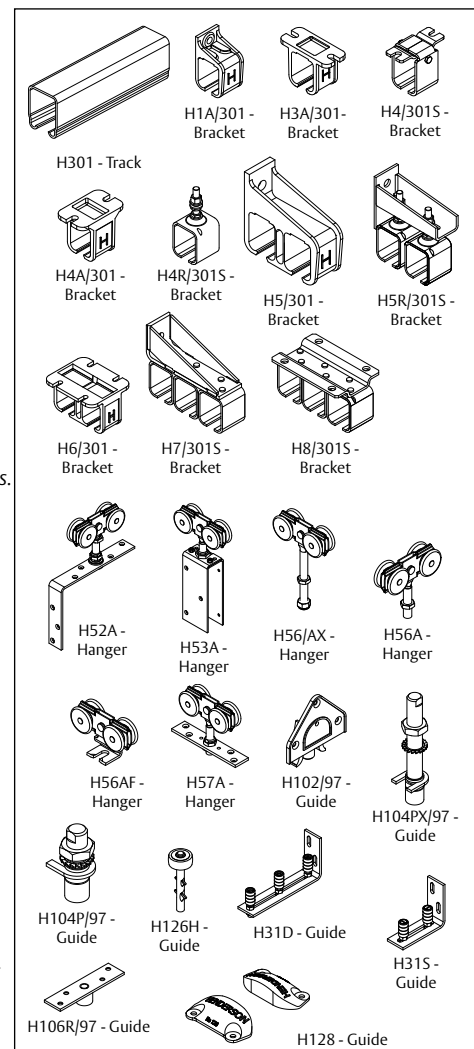

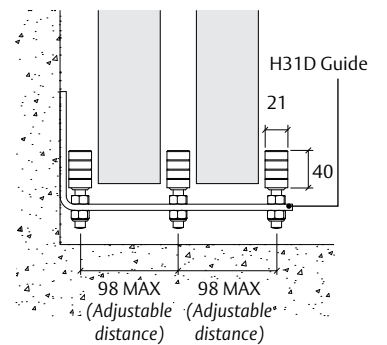
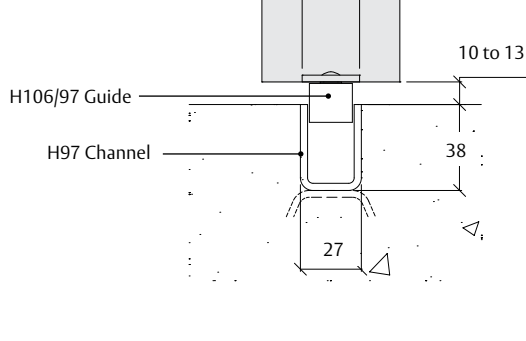
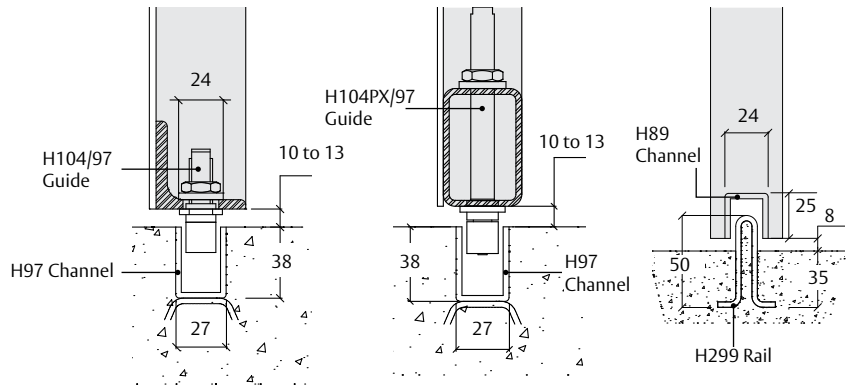
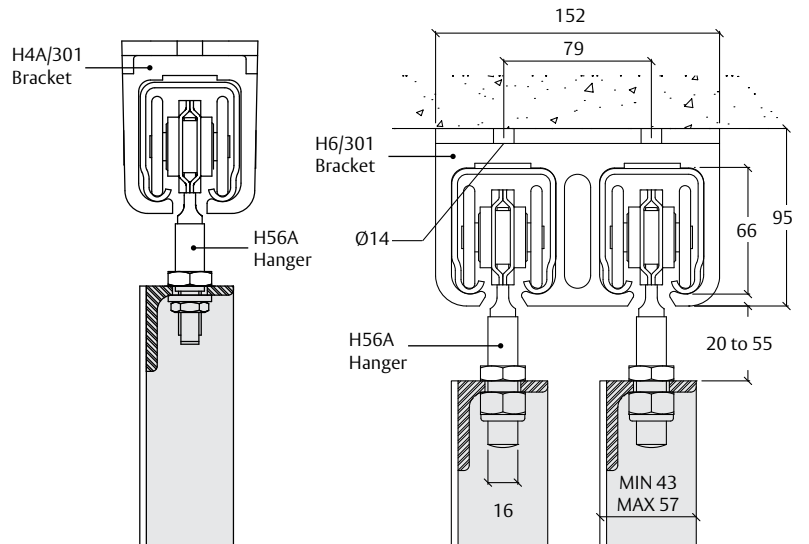
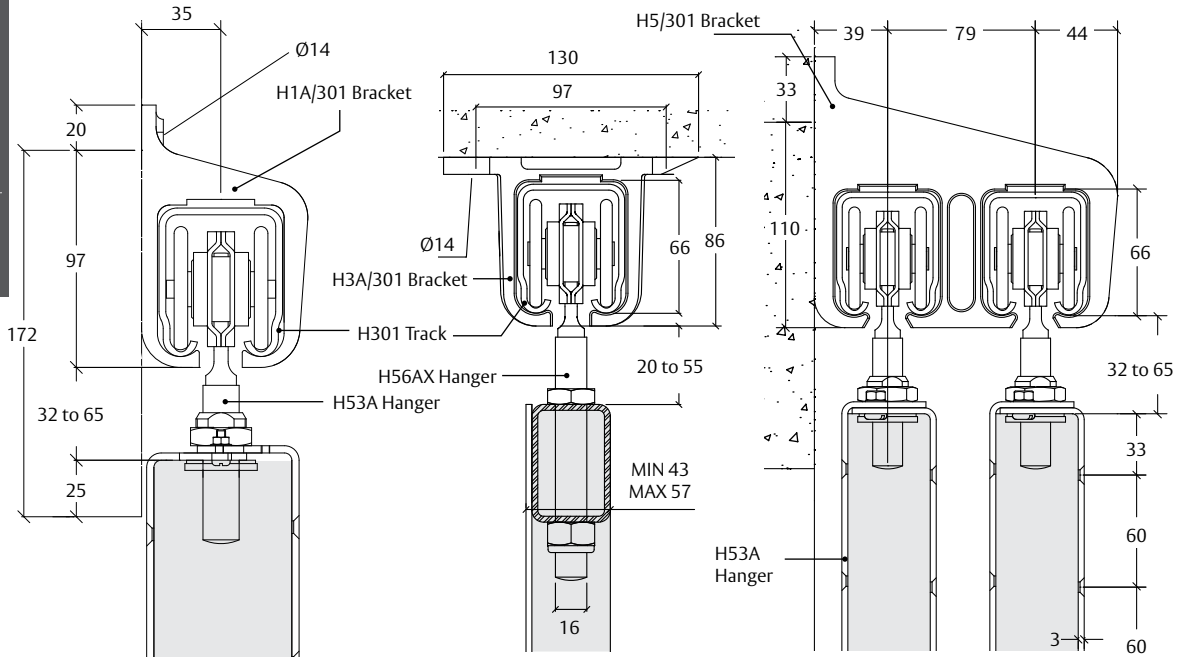

NOT TO SCALE

STRAIGHT SLIDING 305

For timber or metal top hung sliding doors. Max 700kg.

APPLICATION

- Used in commercial, industrial and agricultural applications where robust gear is required
- Designed to accommodate single or multiple panels on one or more tracks
- Designed for interior and exterior applications
- Versatile range of hanger, track, bracket and guide options, allows the 305 system a wide range of applications
- Where doors are fitted externally, a canopy is recommended
- Suitable for Fire Resistant applications

DOOR SPECIFICATION

Track System	305
For Individual Doors:	
Max Door Wt Steel Hanger	700kg
Door Thickness	43-57mm*
Max Door Height	4800mm

* For doors outside the recommended door thickness, please contact our technical sales team for further information.

HARDWARE SPECIFICATION

Track	H305	Galvanised Steel (2000, 2500, 3000, 4000 & 6000mm lengths) Fix spacing at 900mm centres (maximum)
Brackets	H1A/305	Face fix aluminium, single track
	H3A/305	Soffit fix aluminium, single track
	H4A/305	Soffit fix (in line) aluminium, single track
	H4R/305	Soffit fix (adjustable) steel, single track
	H5/305	Face fix aluminium, double track
	H9A/305	Face fix (low headroom) steel, single track <i>For closed and jointing bracket option please contact our Technical Sales Team.</i>
Fire Door Brackets	H1/305	Face fix cast iron, single track
	H1/305L	Face fix cast iron closed left, single track
	H1/305R	Face fix cast iron closed right, single track
	H1X/305	Face fix cast iron jointing, single track
Hangers	H52C/S	Timber doors - angle plate fixing
(2 per door)*	H53C/S	Timber doors - apron fixing
	H56C/S	Metal doors - angle frame
	H56CX/S	Metal doors - box frame
	H57C/S	Timber/metal doors - concealed fixing

* Each panel must be rigid enough to be supported by only two hangers

Guides	H31D	Wall guide, double
	H31S	Wall guide, single
	H102/97	Timber doors
	H104P/97	Metal doors - angle frame
	H104PX/97	Metal doors - box frame
	H106/97	Timber doors - concealed fixing
	H126H	Ground stay roller
	H128	Shoe guide <i>All steel parts are electro zinc-plated.</i>
Channels	H89	Galvanised steel (2000, 3000 & 4000mm lengths)
	H97	Galvanised steel (2000, 3000, 4000 & 6000mm lengths)
Rail	H299	Galvanised steel (2000, 2500 & 3000mm lengths)

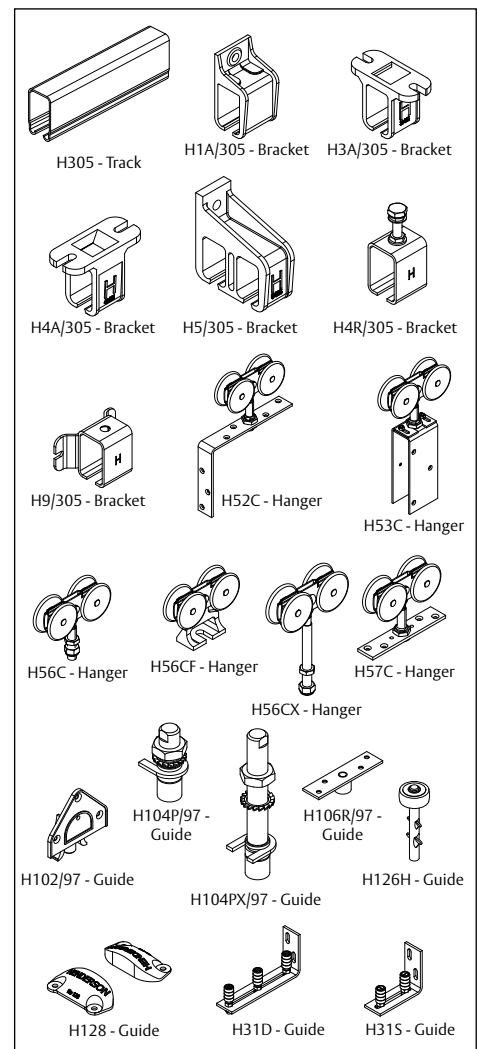

HENDERSON

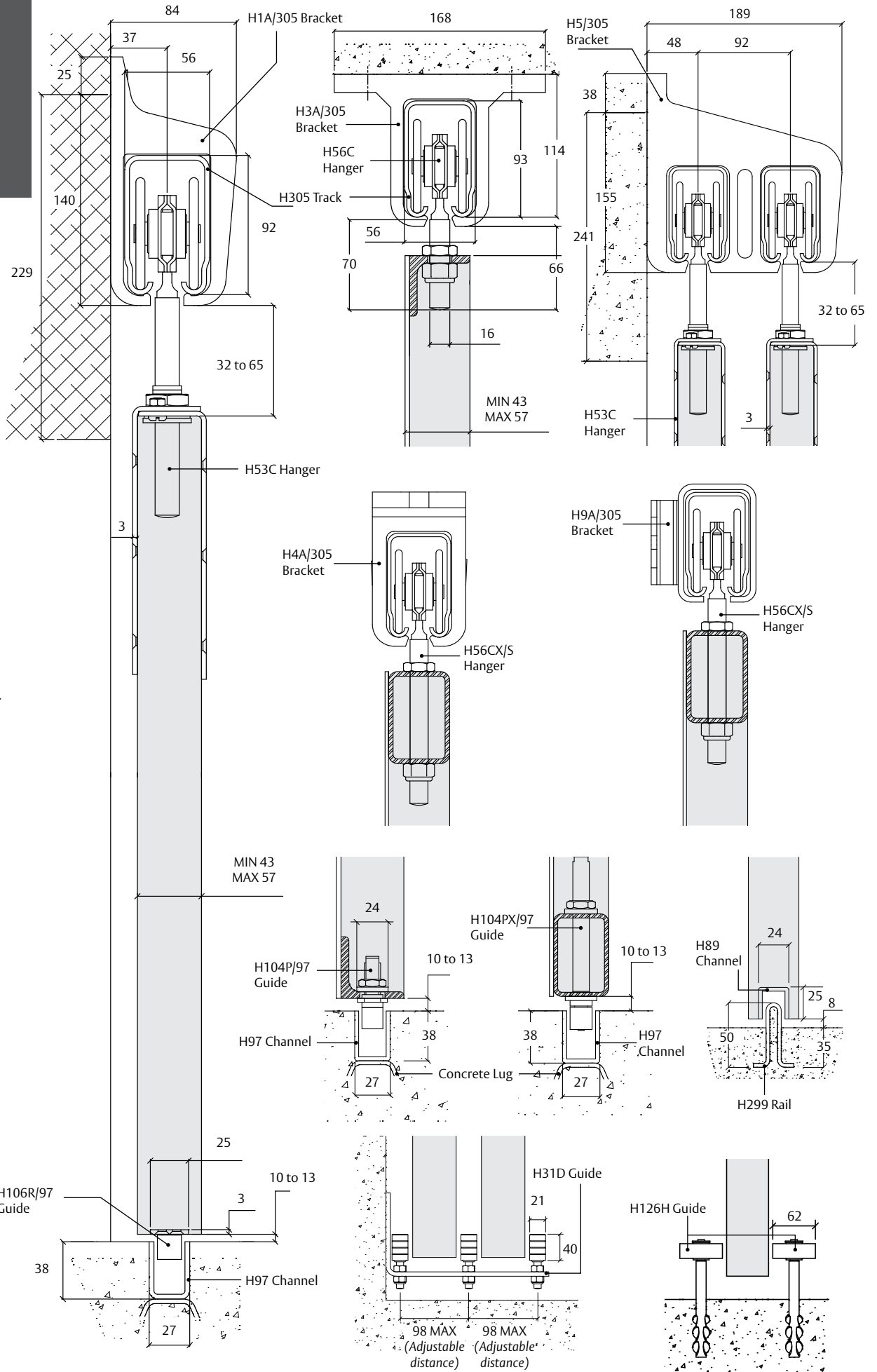

NOT TO SCALE

STRAIGHT SLIDING 307

For timber or metal top hung sliding doors. Max 2000kg.

APPLICATION

- Designed to allow very heavy and large industrial doors to be easily moved
- Designed to accommodate single or multiple panels on one or more tracks
- Versatile range of hanger, track, bracket and guide options, allows the 307 system to be used in a wide range of applications
- Where doors are fitted externally, a canopy is recommended

DOOR SPECIFICATION

Track System 307

For Individual Doors:

Max Door Weight 2000kg
Door Thickness 50-70mm*
Max Door Height 6000mm

* For panels thicker than 70mm, please contact our technical sales team for further information.

HARDWARE SPECIFICATION

Track	H307	Steel Zinc Plated (2000, 3000 & 4000mm lengths) Fix spacing at 900mm centres (maximum)
Brackets	H1/307S	Face fix steel, single track
	H3/307S	Soffit fix steel, single track
	H4/307S	Soffit fix (in line) steel, single track
	H4R/307S	Soffit fix (adjustable), single track
	H5/307S	Face fix steel, double track
	H9/307S	Restricted headroom face fix steel
		<i>For closed and jointing bracket option please contact our Technical Sales Team.</i>
Hangers (2 per door)	H53FJ	Timber doors - apron fixing
	H56FJ	Metal doors - angle frame
	H56FJX	Metal doors - box frame
Guides	H31D	Wall guide, double
	H31S	Wall guide, single
	H102/97	Timber doors
	H104P/97	Metal doors - angle frame
	H104PX/97	Metal doors - box frame
	H106/97	Timber doors - concealed fixing
	H126H	Ground stay roller
	H128	Shoe guide
		<i>All steel parts are electro zinc-plated.</i>
Channels	H89	Galvanised steel (2000, 3000 & 4000mm lengths)
	H97	Galvanised steel (2000, 3000, 4000 & 6000mm lengths)
Rail	H299	Galvanised steel (2000, 2500 & 3000mm lengths)

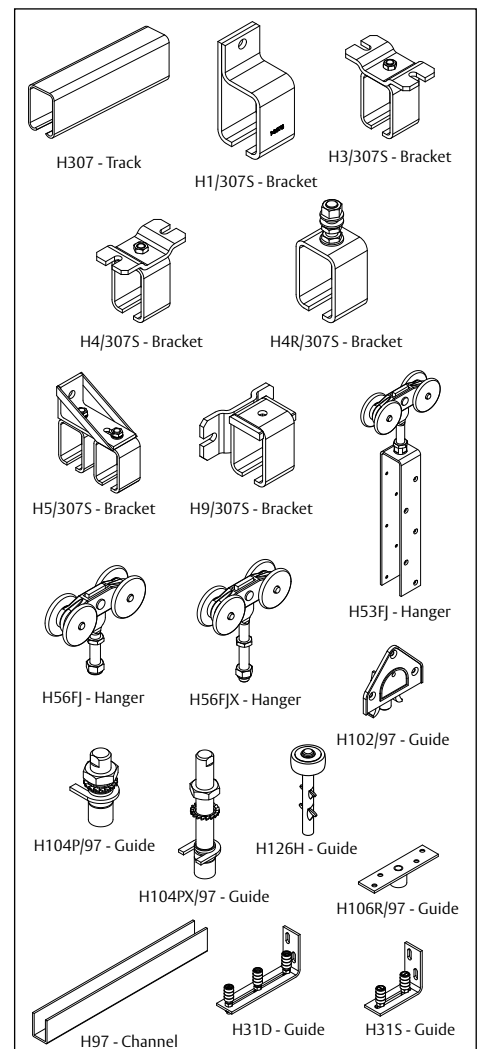



HENDERSON

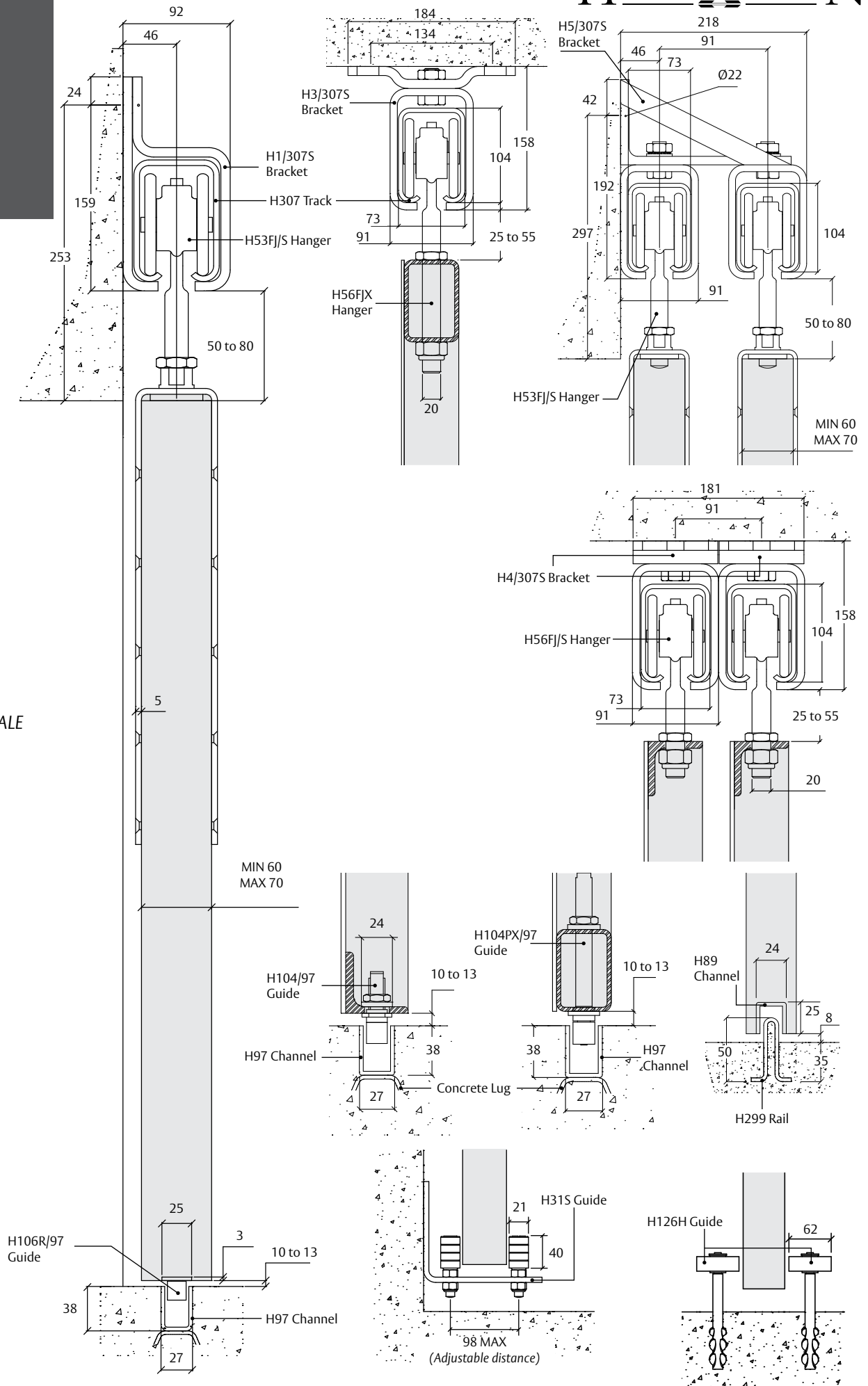

NOT TO SCALE

MIN 60
MAX 70

ISSUE 1-0515

ASSA ABLOY New Zealand Ltd. PO Box 100407, North Shore, Auckland 0745 • 6 Armstrong Road, Albany, Auckland 0632, New Zealand
 Within New Zealand: Tel 09 448 9188 Fax 415 7889 www.assaabloy.co.nz • Online Catalogue: www.assaabloycatalogue.co.nz