

HENDERSON

HENDERSON PRODUCT CATALOGUE

Sliding and Folding Door Hardware



ASSA ABLOY

The global leader in
door opening solutions.

MULTIDIRECTIONAL DOOR SYSTEMS

Section Index and General Guide

Select system for your multidirectional door application.	Residential	Commercial	Industrial	Max. Door	Product	Data Sheet
APPLICATION						
<i>Commercial</i>						
For internal partitions, moveable walls and shopfronts		■		100kg	Flexirol 90°	F20
For internal partitions, moveable walls and shopfronts, showrooms		■		500kg	Flexirol 135°	F30

FLEXIROL 90°

For top hung multidirectional stacking timber and aluminium doors. Max 100kg each.

APPLICATION

- Designed for lightweight panels for internal and external applications requiring 90° movement.
- Typical applications include internal partitions, moveable walls and shopfronts
- Suitable for sliding individual doors to dedicated areas, usually on either side of the opening where folding doors would not be suitable
- Floor channel is not necessary since the doors may be secured in position by stops, flush bolts or locks
- To cover any width of opening, any number of panels can be used

DOOR SPECIFICATION

Track System	Flexirol 90°
For Individual Doors:	
Max Door Weight	100kg-2 hangers per leaf 50kg-1 hanger per leaf
Max Door Width	6000mm
Min Door Thickness	40-100mm*
Max Door Height	6000mm
Max swing door width	1200mm

* For doors thicker than 100mm, please contact our technical sales team for further information.

HARDWARE SPECIFICATION

Track	H550	Anodised Aluminium (2000, 3000, 4000 & 6000mm lengths) See Components Section for full range of finishes
Track Intersects & Elbows	HTW/550 HKW/550 H90/550	Aluminium 'T' junction Aluminium cross-junction Aluminium elbow
Brackets	H1A/550 H3S/550	Face fixed Soffit fixed
Hangers (2 per door)*	H555/21 H555/61	Timber Doors - angle plate fixing Timber Doors - concealed plate fixing Stainless steel ballrace wheels and components. Vertical adjustment is simple and positive.
* Each panel must be rigid enough to be supported by only two hangers		
Pivot Set	H21/550P	Top and bottom pivots for single access door
Track Stop	HH3/301	Flexirol track stop
Guides	H106HSS/94 H21R/94 H104N/94	Timber Doors - concealed fixing Timber Doors - angle plate fixing Metal Doors - angle frame fixing
Channels	H94X H94P H94PSC	Aluminium (2000, 3000, 4000 & 6000mm lengths) Polypropylene (2000, 3000, 4000 & 6000mm lengths) Aluminium supporting channel and polypropylene (2000, 3000, 4000 & 6000mm lengths)

Accessories

Flush Bolts	HSF190S HSF190LS
-------------	-----------------------------------

IMAGE
COMING
SOON

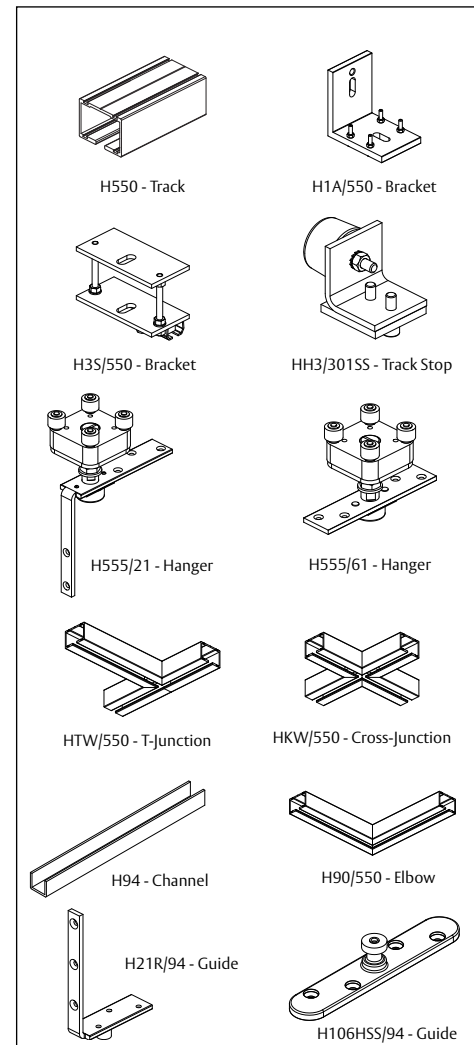

H
E
N
D
E
R
S
O
N

90° Configurations

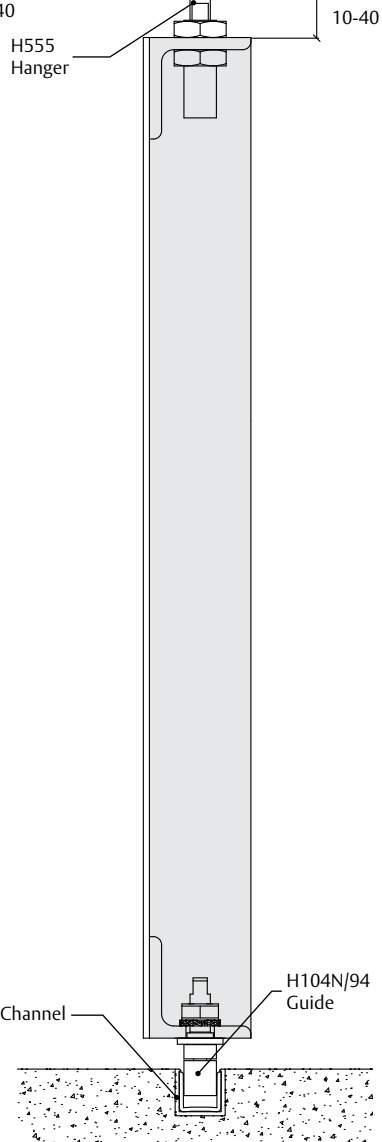
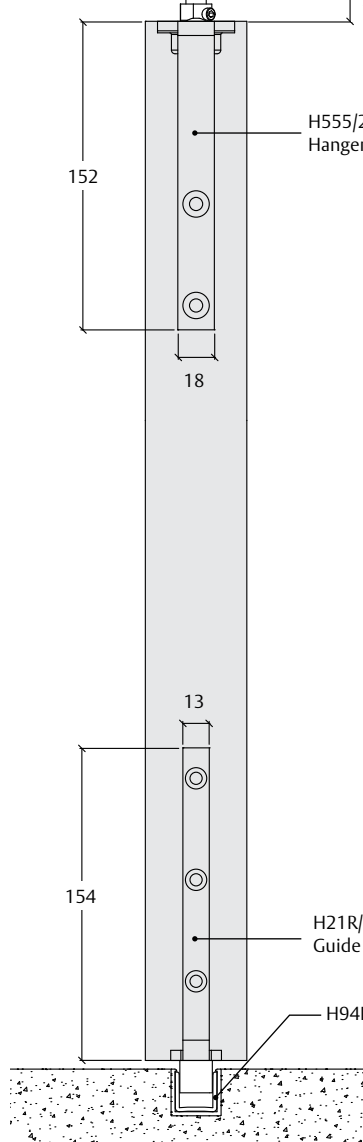
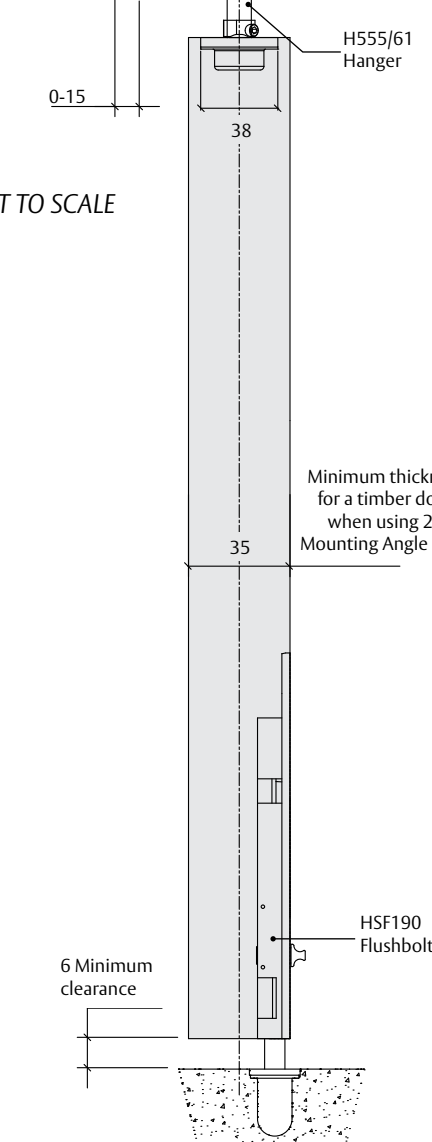
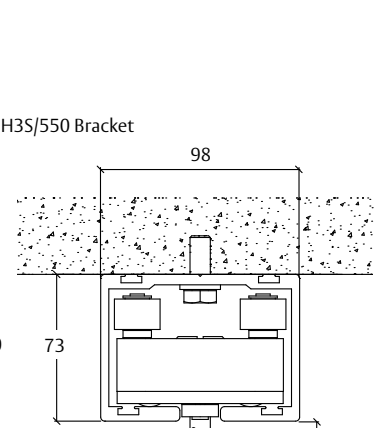
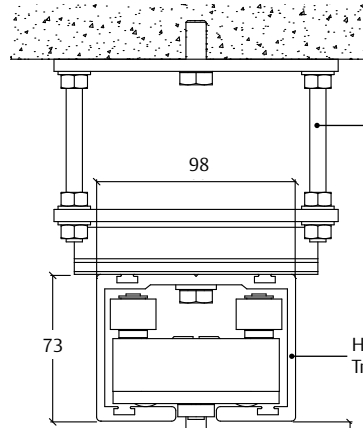
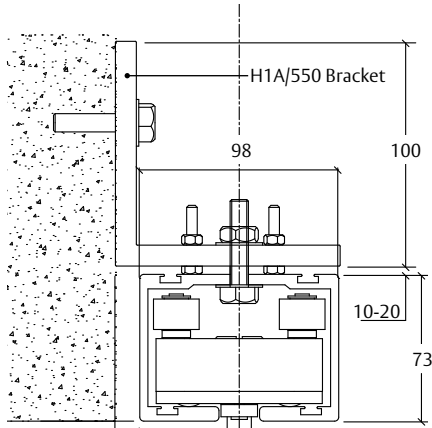
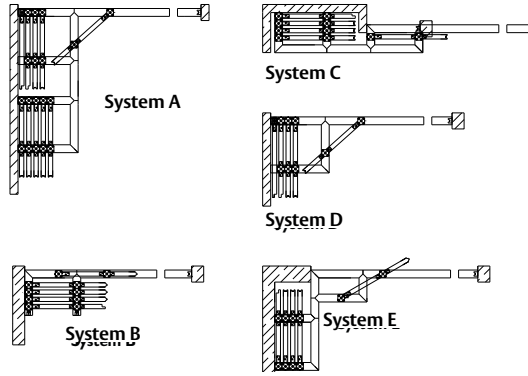

NOT TO SCALE

HENDERSON

FLEXIROL 135°

For top hung multidirectional stacking timber and aluminium doors. Max 500kg each.

APPLICATION

- Designed for heavy panels for internal applications requiring 135° movement. Typical applications include internal partitions, moveable walls and shopfronts, showrooms and conference centres
- Suitable for sliding individual doors to dedicated areas, usually on either side of the opening where folding doors would not be suitable
- Floor channel is not necessary since the doors may be secured in position by stops, flush bolts or locks
- To cover any width of opening, any number of panels can be used
- Can be configured in a number of different stacking designs/systems

DOOR SPECIFICATION

Track System	Flexirol 135°
For Individual Doors:	
Max Door Weight	500kg – 2 hangers per leaf 250kg – 1 hanger per leaf
Max Door Width	6000mm
Min Door Thickness	40-100mm*
Max Door Height	6000mm
Max swing door width	6000mm

* For doors thicker than 100mm, please contact our technical sales team for further information.

HARDWARE SPECIFICATION

Track	H550	Anodised Aluminium (2000, 3000, 4000 & 6000mm lengths) See Components Section for full range of finishes
Track Intersects & Elbows	H45(LorR)/550 H135/550 H90L/550 HW90(LorR)/550	Anodised Aluminium 135° intersect (LH or RH) Anodised Aluminium elbow Anodised Aluminium 90° swept elbow for 135° hanger Anodised Aluminium 90° swept elbow for 135 hanger (LH or RH)
Brackets	H1A/550 H3S/550	Face fixed Soffit fixed
Hangers	H556 (2 per door)* H556/21 H556/61	Metal doors - angle frame fixing Timber Doors - angle plate fixing Timber Doors - concealed plate fixing
* Each panel must be rigid enough to be supported by only two hangers		
Pivot Set	H21/550P	Top and bottom pivots for single access door
Track Stop	HH3/301	Flexirol track stop
Guides	H106R/94 H21R/94	Timber Doors - concealed fixing Timber Doors - angle plate fixing
Channels	H94X H94P H94PSC	Aluminium (2000, 3000, 4000 & 6000mm lengths) Polypropylene (2000, 3000, 4000 & 6000mm lengths) Aluminium supporting channel and polypropylene (2000, 3000, 4000 & 6000mm lengths)

Accessories

Flush Bolts	HSF190S HSF190LS
-------------	-----------------------------------

IMAGE
COMING
SOON

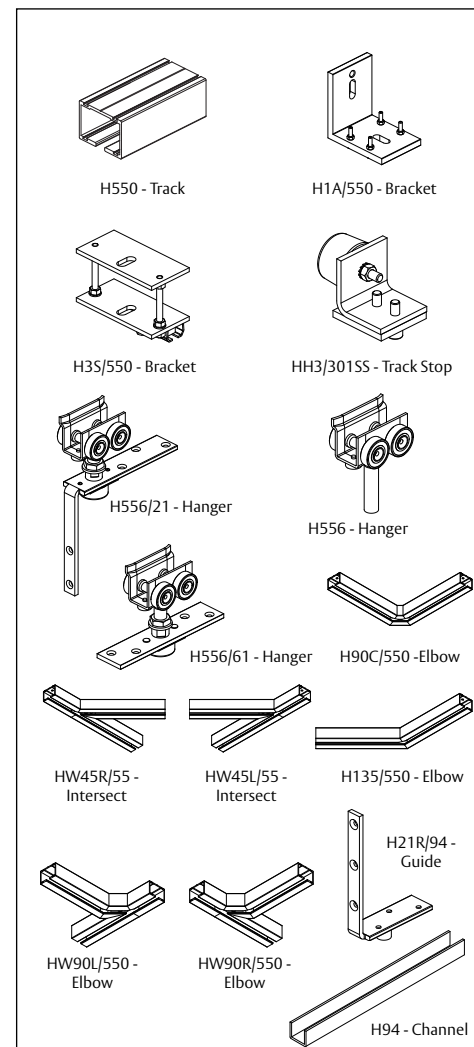

HENDERSON

135° Configurations

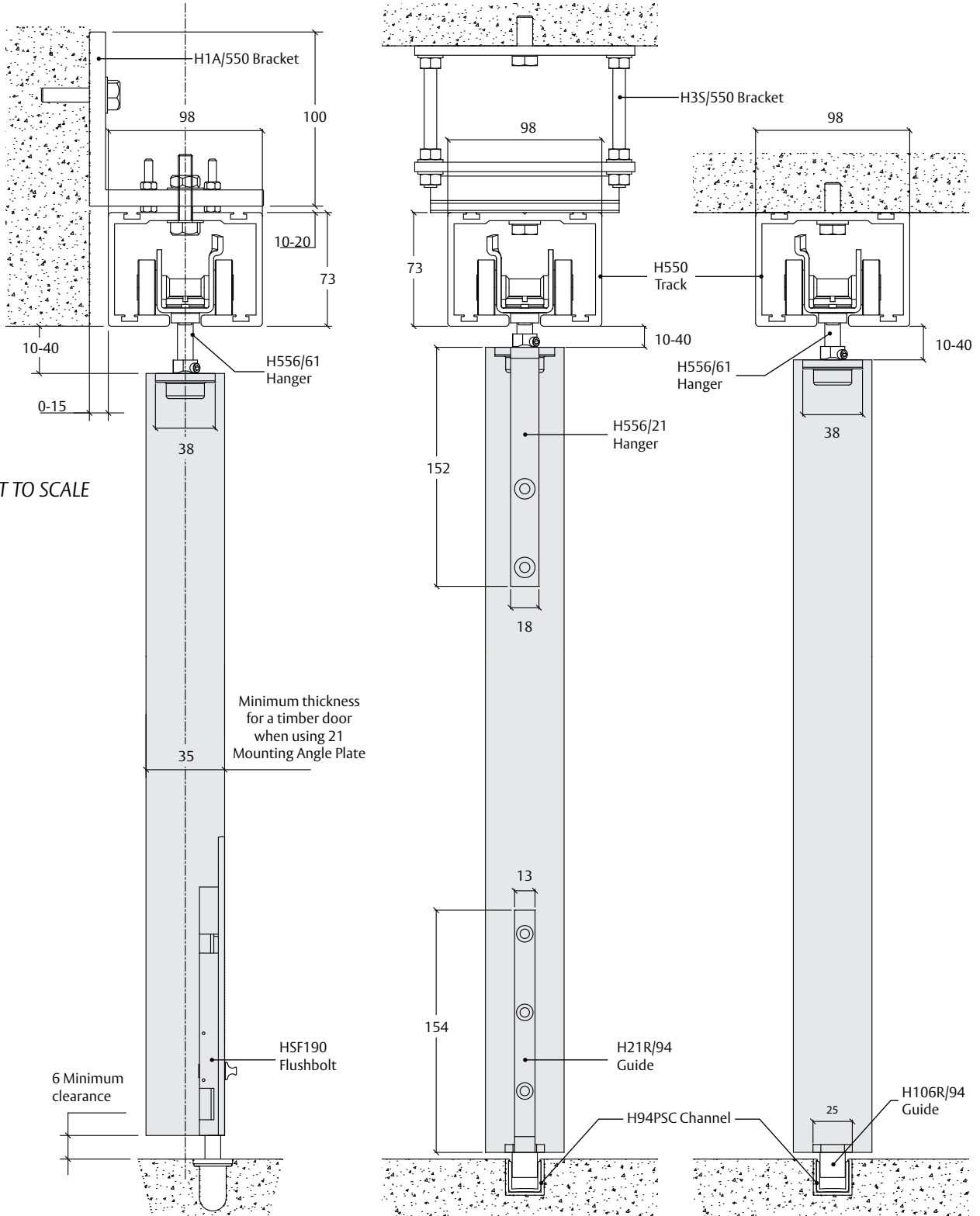
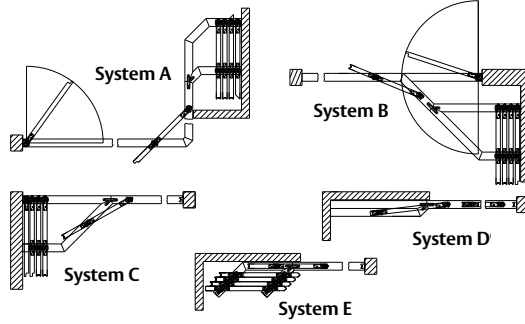

HENDERSON