

MASONS UNI® FLEXIBLE AIR BARRIER

DESIGN AND INSTALLATION GUIDE



MASONS
Designed Smart, Built Tough.

V1.0 October 2021

General and product information

PURPOSE

This design and installation guide relates to Masons UNI® Flexible Air Barrier (UNI® FAB).

IMPORTANT DOCUMENTS

This guide must be read in conjunction with:

- › Masons UNI® FAB pass™
- › Masons UNI® FAB Warranty
- › Masons UNI® FAB Installation Video.

SKILLS REQUIRED

This guide is suitable for use by a competent designer and person with basic carpentry skills. Where applicable the person specifying, supervising or installing the Masons UNI® FAB must be able to meet all RBW provisions.

FOR MORE HELP

Technical assistance is available at www.mpb.co.nz.

While all reasonable efforts have been made to ensure the accuracy of information provided, this guide is a guide only. It may be subject to change.

FOR OUR WARRANTY

Refer to www.mpb.co.nz.

PRODUCT DESCRIPTION

UNI® FAB is a nonwoven, absorbent, water-resistant, 180 GSM, synthetic wall underlay. It comprises three polypropylene layers: two outer layers of nonwoven polypropylene with a middle layer of a functional-technical film. It is manufactured to meet the European standard EN 13859-2:2014 as well as the absorbency performance requirement as per NZS 2295:2006. It is supplied coloured blue with a black underside unless an alternative colour is requested.

SCOPE AND LIMITATIONS

For scope of use, limitations, conditions and statement of building code compliance, refer to the Masons UNI® FAB pass™.



Design

STEP 1:

CONFIRM SCOPE

Confirm the proposed use is within the scope and limitations of the pass™.

STEP 2:

CONFIRM RELATED BUILDING WORK

Masons UNI® FAB is suitable for use with a timber or steel framed structure. For new and existing buildings confirm that the primary structure:

- › complies with the NZ Building Code and is designed in accordance with NZS 3604:2011 or NASH Design Standard 2019 Parts 1 and 2; or
- › is specifically designed to NZS 3603:1993 or AS/NZS 1170:2002; or
- › where existing, is suitable for the intended building work.

Masons UNI® FAB can be used with a cladding fixed over a cavity or direct fixed. Confirm whether the design includes a cavity system or not and determine the type and orientation of the battens. Ensure cavity battens specified are timber battens. Ensure that the framing meets, as a minimum the requirements in Table 1.

STEP 3:

SPECIFY FIXINGS

FIXING TABLE

Specify Masons UNI® fastener fixings in accordance with Table 1. Masons UNI® Fasteners are 25 mm galvanised or stainless steel nails with a plastic washer.

STEP 4:

SPECIFY ANCILLARY PRODUCTS

Ensure all required ancillary products are specified in the completed Masons UNI® FAB specification.

STEP 5:

QUALITY CHECK

Confirm all relevant design requirements are met. Collate the following documents and include in the building consent application:

- › Masons UNI® FAB pass™,
- › Masons UNI® FAB Specification,
- › Masons UNI® FAB Warranty and
- › this document.



Pre-installation

HEALTH AND SAFETY

Take all necessary steps to ensure your safety and the safety of others:

- › ensure adequate ventilation or mechanical dust extraction when cutting or drilling
- › take care when fixing the wrap in windy conditions
- › wear appropriate safety equipment, clothing and footwear
- › use all tools in accordance with relevant instruction manuals
- › plan and monitor a safe approach for working at height; select and use the right equipment
- › clear the work area of any obstruction before work starts.

For further information refer to:

- › WorkSafe. [July 2018] Small Construction Sites, the Absolutely Essential Health and Safety Toolkit.
- › WorkSafe. [December 2016] Health and Safety at Work, Quick Reference Guide.

These documents are available at www.worksafe.govt.nz.

HANDLING AND STORAGE

Handling

Care must be taken during loading, unloading, and transporting the materials to prevent pre-installation damage.

Unload the rolls carefully by hand. Do not crush the rolls and ensure they are protected from damage.

Storage

Store the rolls on end under a cover, in a clean and dry area and out of direct sunlight.

TOOLS AND EQUIPMENT REQUIRED

Install Masons UNI® FAB using standard carpentry tools and equipment. Use tools in accordance with good trade practice and supplier's instructions.



CN100 UNI Cap Nailer Gun



UNI Fasteners



UNI FAB Seam Tape



40 Below Flashing Tape

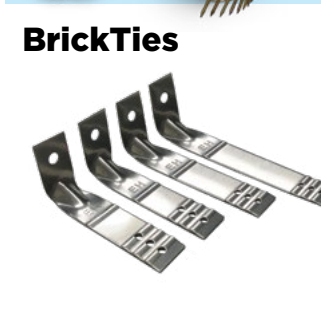

BrickTies



P Seals



Corner Guards



PEF Rod



Installation

STEP 1:

BUILDING CONSENT DOCUMENTATION

Where applicable, access and view building consent documentation.

STEP 2:

CHECK RELATED BUILDING WORK

For new and existing buildings ensure the primary structure is straight and true and within framing tolerances as described in Table 2.1, section 2 of NZS 3604:2011.

Masons UNI® FAB can be used where cladding is installed over a cavity system or direct fixed cladding.

STEP 3:

INSTALL WRAP

For assistance in installing UNI® FAB refer to video.

DIAGRAM 0.1

Fit Wrap

Ensure all necessary equipment and ancillary components are available.

Masons UNI® FAB must be installed with the printed side out, typically run horizontally on vertical framing. However, it is non directional and may be run in line with raking soffit lines or gables.

Fixing

Masons supply Masons UNI® Fasteners for both timber and lightweight steel framing.

Ensure battens are fixed to Table 1 (as a minimum) or to the building consent.

Where cavity battens are to be installed, fix Masons UNI® FAB to frames at the plates and nogs/dwangs using the applicable Masons UNI® Fasteners. Do not fix to the studs. When fixing vertical or horizontal cavity battens ensure batten nails are a minimum of 100 mm away from the UNI® Fastener.

Fasten battens promptly to prevent wind blow out whilst 'UNI® FAB is tacked up' with reduced numbers of cap nails.

Where bulging has or is likely to occur secure with Masons Wrap Strap.

DIAGRAM 0.9



DIAGRAM 0.1

Fit UNI® FAB Soffit

The use of UNI® FAB Soffit is optional.

Run UNI® FAB soffit (self-adhesive strip at the bottom) along the top face and level with the top plate. Ensure that it is taut. Secure in accordance with Table 1.

Do not fasten the bottom of the soffit strip as this needs to overlap the next layer of UNI® FAB.

DIAGRAM 0.1

Fit UNI® FAB

Where UNI® Soffit has been installed:

- › Hold the soffit strip up to allow the horizontal installation of the UNI® FAB. Ensure that the soffit layer overlaps the lower layer by 150 mm.
- › Fold the soffit layer down, peel the self-adhesive backing strip down and ensure adhesion by applying pressure with the plastic tape scraper.

Where UNI® Soffit has not been installed:

- › Run UNI® FAB along the top face, level with the top plate. Ensure that it is taut. Ensure the wrap extends a minimum of 50 mm below the bottom plate or bearer.

Ensure the wrap is taut and does not belly into the cavity or openings. Fix in accordance with the building consent or Table 1.

Run the wrap over all openings and leave openings covered until windows and doors are ready to be installed.

DIAGRAM 0.1

Where UNI® Soffit has not been installed:

Run UNI® FAB along the top face, level with the top plate. Ensure that it is taut. Ensure the wrap extends a minimum of 50 mm below the bottom plate or bearer. Secure in accordance with Table 1.

- › Ensure the wrap is level and is pulled taut so that the wrap does not belly into the cavity.
 - › Run the wrap over all openings and leave openings covered until windows and doors are ready to be installed
-



DIAGRAM 0.1

Laps

Masons UNI® FAB must lap a minimum of 150 mm at horizontal joints and over framing wherever possible. Vertical joints must always be over framing and a minimum of 150 mm lap.

Upper wrap sheets must lap over lower wrap sheets to ensure water is shed outside the wrap.

All laps must be taped off with 60 mm Masons UNI® FAB Seam and Repair Tape or Masons 40 Below Flashing Tape (Flex or Platinum). Ensure adhesion by applying pressure using a plastic scraper.

If UNI® FAB is to be used as temporary weather protection, ensure all joins have been sealed using Masons UNI® FAB Seam and Repair Tape, the self-adhesive strip on the reverse of the UNI® Soffit roll, or Masons 40 Below (Flex or Platinum) Flashing Tape. The roof cladding and soffit linings must also have been installed.

DIAGRAM 0.8

Penetrations

Pipe penetrations must be sealed using Masons Penetration seals or similar, ensuring good adhesion by applying pressure with a plastic scraper.

DIAGRAM 0.7

Intersections – Apron Flashings, Interstorey Flashings, Change of pitch

Drape UNI® FAB over the upstand of apron, change of pitch or inter storey flashings. The UNI® FAB length should extend beyond the flashing by 100 – 150 mm at each end. Secure with UNI® Fastenings. Tape all laps with UNI® 40 Below (Flex or Platinum) Flashing Tape.

Tears

Regularly check Masons UNI® FAB for damage, tears, holes and gaps. Any damaged areas must be repaired immediately.

Repair by covering with new wrap lapping the damaged area by at least 150 mm and tape the wrap using Masons UNI® Seam and Repair Tape.

Small tears can be repaired by taping with Masons UNI® Seam and Repair Tape.



STEP 5

PREPARE OPENINGS

DIAGRAM 0.2

Openings

Remove the wrap by cutting the wrap diagonally from each corner of the opening. Fold the flaps of the cut membrane inside the opening. Staples may be used to fix the wrap to the inside of the window frame. Cut excess wrap flush with the internal face of the framing.

Flashing tape must be installed to all openings. Masons 40 Below (Flex or Platinum) Flashing Tape must be used.

All exposed wall framing in the openings must be protected by the Masons UNI® FAB, and Masons 40 Below Flashing Tape.

To ensure the best possible adhesion make sure the substrate is clean, dry, free from dust or any other contaminants.

DIAGRAM 0.3

Window & Door sills

Place Masons Corner Guard over the Masons UNI® FAB and into the bottom corners of the window or door sill and staple to the jamb for timber framing or attach with double sided tape for steel framing.

Install Masons 40 Below (Flex or Platinum) Flashing Tape flush with the interior face of the opening along the entire length of the sill and up each jamb to a minimum of 200 mm. Press tape firmly into the corner over the guard first then slit at each corner and fold around onto the frame face. Fold remainder of the tape against the outer face of the frame and press firmly using the plastic scraper.

DIAGRAM 0.3

Window and door heads

Install lintel pieces at top corners of opening, 200 mm along the lintel and 200 mm down the jamb. Slit Masons UNI® FAB at each corner and fold at least 50 mm onto outer face of building wrap. To create a seal at corner junctions, install butterflies at 45° across the corner of the head/jamb.



STEP 6:

DIAGRAM 0.2

INSTALL JOINERY

Install window and door joinery with head flashings and air seals.

Masons recommends Running Masons Dry Fix Plastic DPC up the side of the window jambs and under the head flashing. Where plastic DPC is installed around joinery as secondary water proofing such as for brick veneer work, fasten the DPC to the frame over the wrap using Masons UNI® Fasteners.

To seal above the head flashing, Masons recommends installing UNI® FAB so that it drapes over the head flashing extending the length of the flashing by 100 - 150 mm at each end. Secure with UNI® Fastenings. Tape all laps with UNI® 40 Below (Flex or Platinum) Flashing Tape. This method of sealing is mandatory at wind zones very high and above.

For wind zones less than very high, the head flashing may be sealed to the UNI® FAB using UNI® Seam and Repair Tape or UNI® 40 Below (Flex or Platinum) Flashing Tape.

STEP 7:

QUALITY CHECK

Ensure that all joints are taped, and all tears have been repaired. Ensure full adhesion around penetrations and openings.

Ensure Mason's warranty is inserted into the client document package.



Appendix 1

TABLE 1: FIXING TABLE

Stud centres (mm)	Fixings on studs (mm)	Minimum nogs centre (mm)	Perimeter fixing all around	Wind Zone	Fixing on Fixings nogs
600	Nail at 450 mm centres	800	Nail at 300 mm centres	Low/ Medium	Nail at centre 25 mm nails with plastic washer
450	Nail at 500 mm centres	800	Nail at 300 mm centres	Low/ Medium	Nail at centre 25 mm nails with plastic washer
400	Nail at 450 mm centres	800	Nail at 300 mm centres	Low/ Medium	Nail at centre 25 mm nails with plastic washer
600	Nail at 300 mm centres	800	Nail at 300 mm centres	High	Nail at centre 25 mm nails with plastic washer
450	Nail at 350 mm centres	800	Nail at 300 mm centres	High	Nail at centre 25 mm nails with plastic washer
400	Nail at 300 mm centres	800	Nail at 300 mm centres	High	Nail at centre 25 mm nails with plastic washer
400	Nail at 250 mm centres	800	Nail at 300 mm centres	Low/ Medium/ High/ Very High	Nail at centre 25 mm nails with plastic washer
300	Nail at 300 mm centres	800	Nail at 300 mm centres	Low/ Medium/ High/ Very High/ Extra High	Nail at centre 25 mm nails with plastic washer
300	Nail at 250 mm centres	800	Nail at 300 mm centres	Low/ Medium/ High/ Very High/ Extra High	Nail at centre 25 mm nails with plastic washer
300, 400, 450, 600	Battens with nails at 400 mm centres	800	Batten with nails at 300 mm centres	Low/ Medium/ High/ Very High/ Extra High	Battens with nails at 400 mm centres (2 nails min) Batten - 20 x 45 SG8 Nails - 60 2.8 ring shank galvanised

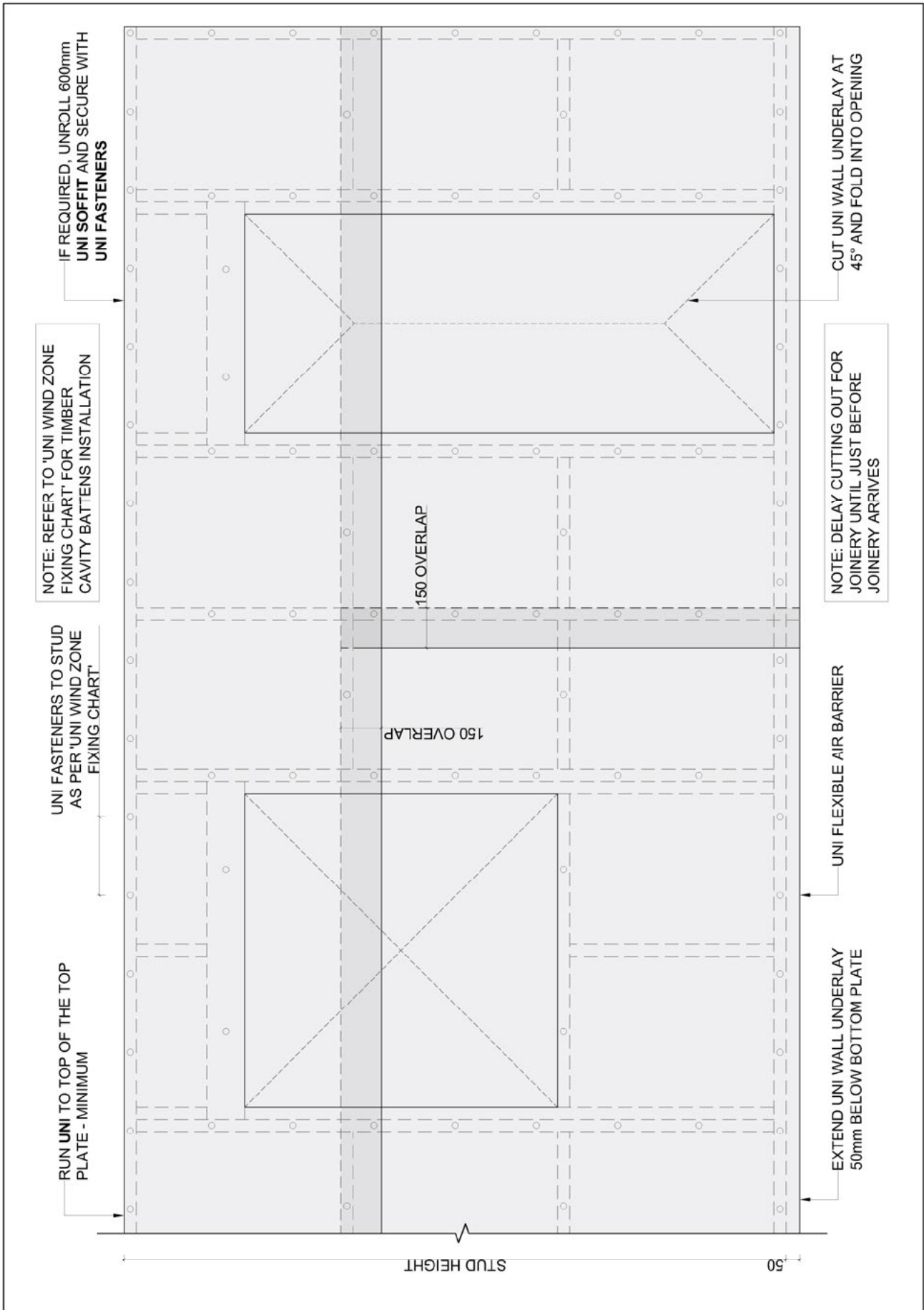

 <p>MASONS Designed Smart, Built Tough.</p>	<p align="center">UNI FAB, UNI Plus & UNI Pro The Primary UNI Setout on Studs with UNI Fasteners</p> <p align="center">*UNI fasteners & UNI cap nails are used interchangeably</p>	Scale	Date
		1:20	
		Drawing Ref No.	UNI.01

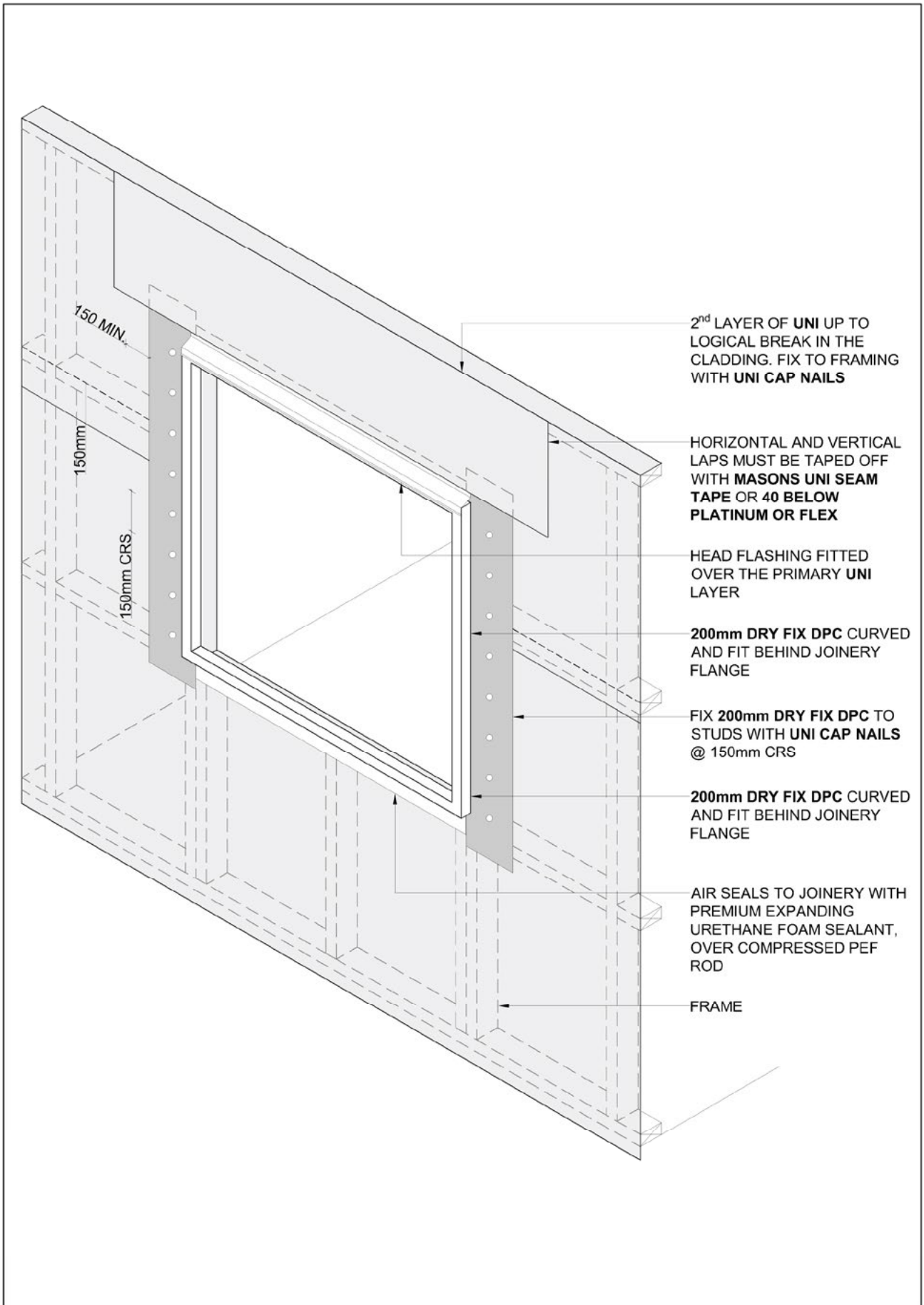

- 2nd LAYER OF UNI UP TO LOGICAL BREAK IN THE CLADDING. FIX TO FRAMING WITH UNI CAP NAILS
- HORIZONTAL AND VERTICAL LAPS MUST BE TAPED OFF WITH **MASON'S UNI SEAM TAPE OR 40 BELOW PLATINUM OR FLEX**
- HEAD FLASHING FITTED OVER THE PRIMARY UNI LAYER
- 200mm DRY FIX DPC CURVED AND FIT BEHIND JOINERY FLANGE**
- FIX **200mm DRY FIX DPC** TO STUDS WITH **UNI CAP NAILS @ 150mm CRS**
- 200mm DRY FIX DPC CURVED AND FIT BEHIND JOINERY FLANGE**
- AIR SEALS TO JOINERY WITH PREMIUM EXPANDING URETHANE FOAM SEALANT, OVER COMPRESSED PEF ROD
- FRAME

 MASONS <small>Designed Smart, Built Tough.</small>	UNI FAB, UNI Plus & UNI Pro Setout on Timber Frame Additional Layer of UNI over Head Flashing	Scale	Date
		1:20	
		Drawing Ref No.	
		UNI.02	

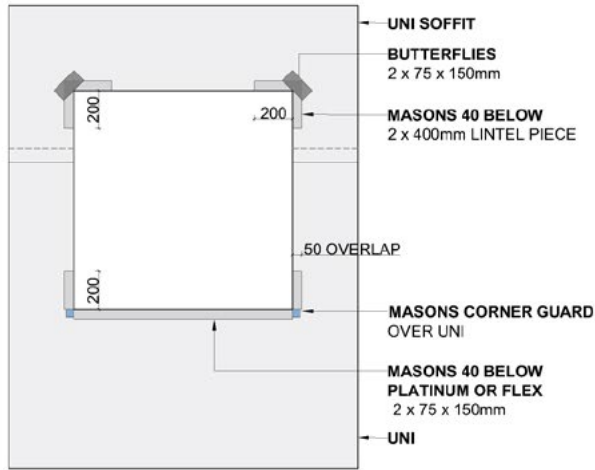

STEP ONE

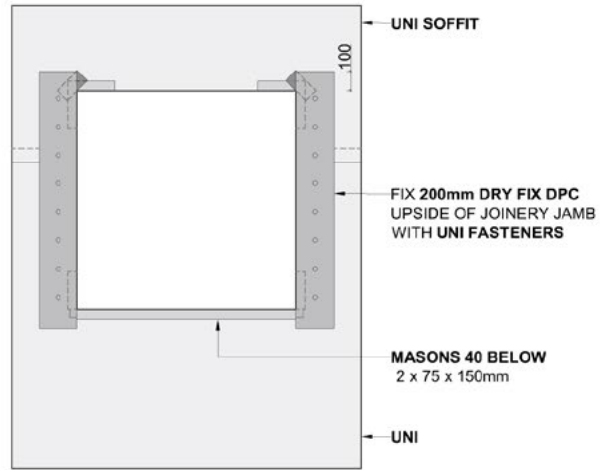

STEP TWO

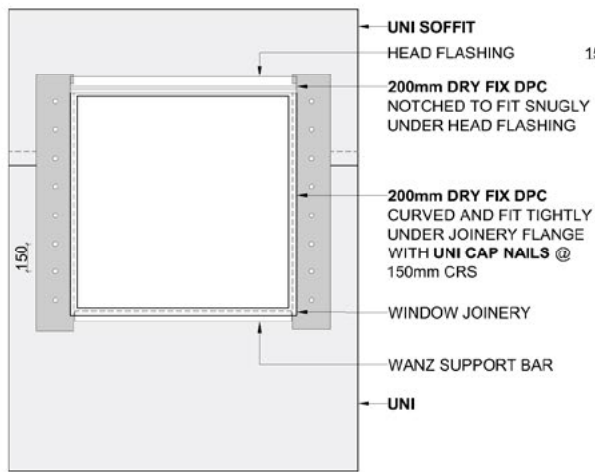

STEP THREE

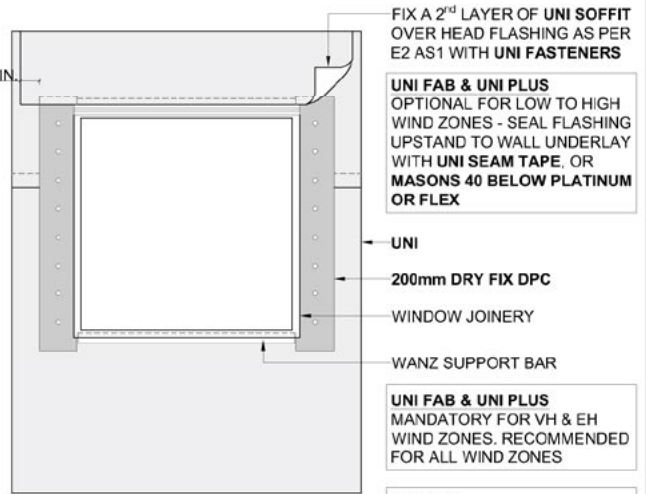

STEP FOUR



Window Installation
 UNI FAB, UNI Plus & UNI Pro

Scale
 1:40

Date

Drawing Ref No.

UNI.03

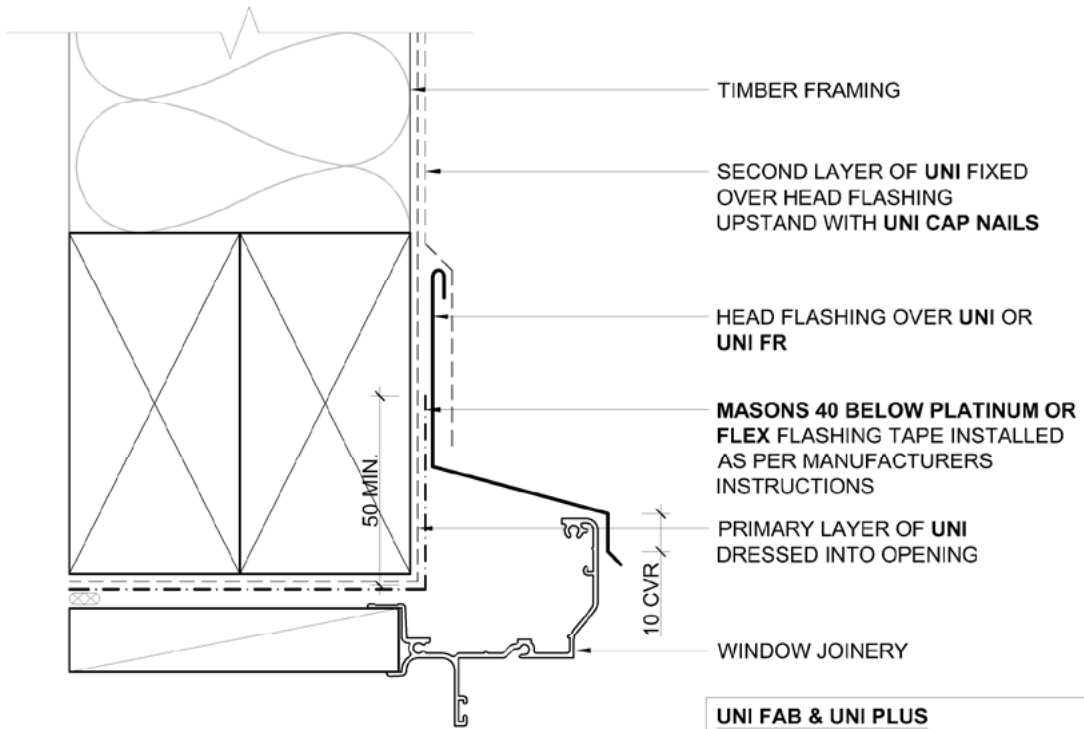

ADDITIONAL UNI OVER HEAD FLASHING

UNI FAB & UNI PLUS
MANDATORY FOR VERY HIGH AND EXTRA HIGH WIND ZONE. RECOMMENDED FOR ALL WIND ZONES

UNI PRO
MANDATORY FOR ALL WIND ZONES

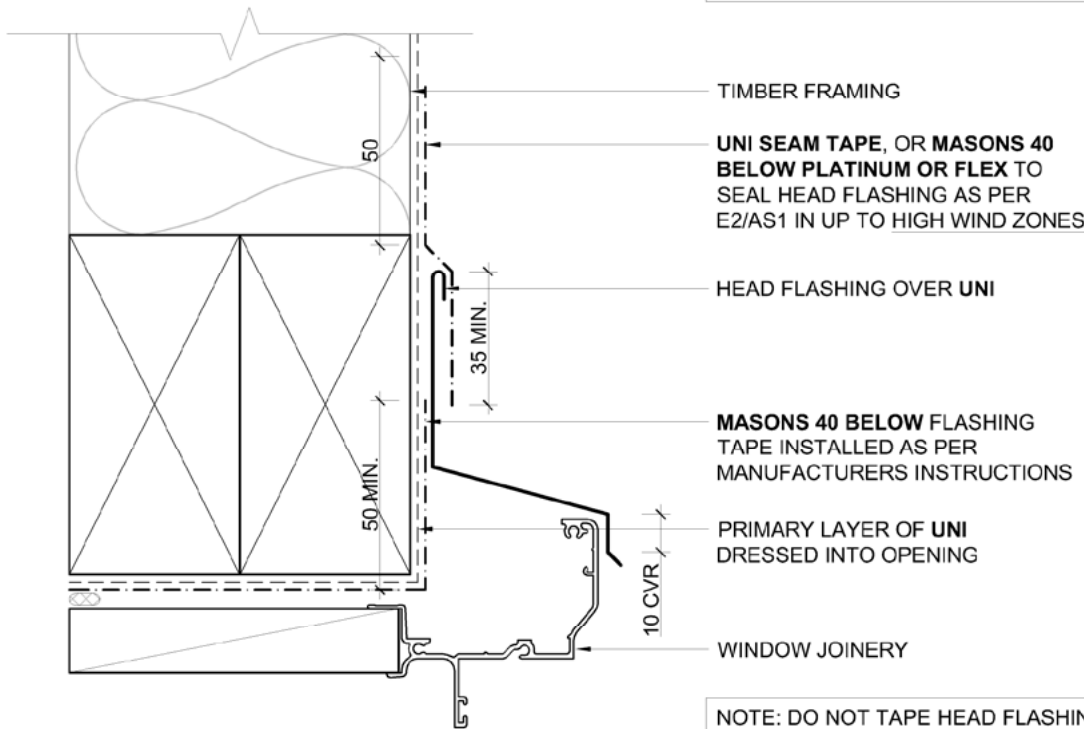

FLASHING TAPE OVER HEAD FLASHING

NOTE: DO NOT TAPE HEAD FLASHING ON UNI PRO. USE ADDITIONAL LAYER OF UNI TO ALL WIND ZONES

 <p>MASONS Designed Smart, Built Tough.</p>	<p>Window Head Head Flashing to UNI FAB, UNI Plus & UNI Pro</p>	Scale	Date
		1:2	
		Drawing Ref No.	
		UNI.04	

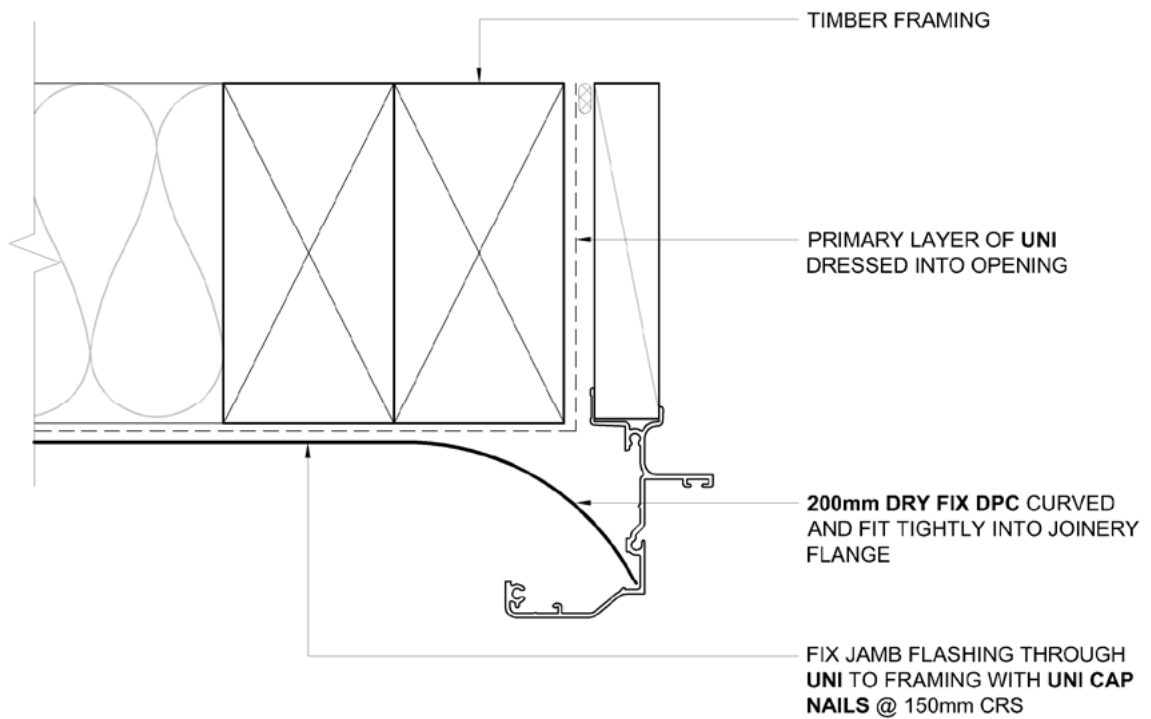

 MASONS Designed Smart, Built Tough.	Typical Jamb with 200mm Plastic DPC UNI FAB, UNI Plus & UNI Pro	Scale	Date
		1:2	
		Drawing Ref No.	
		UNI.05	

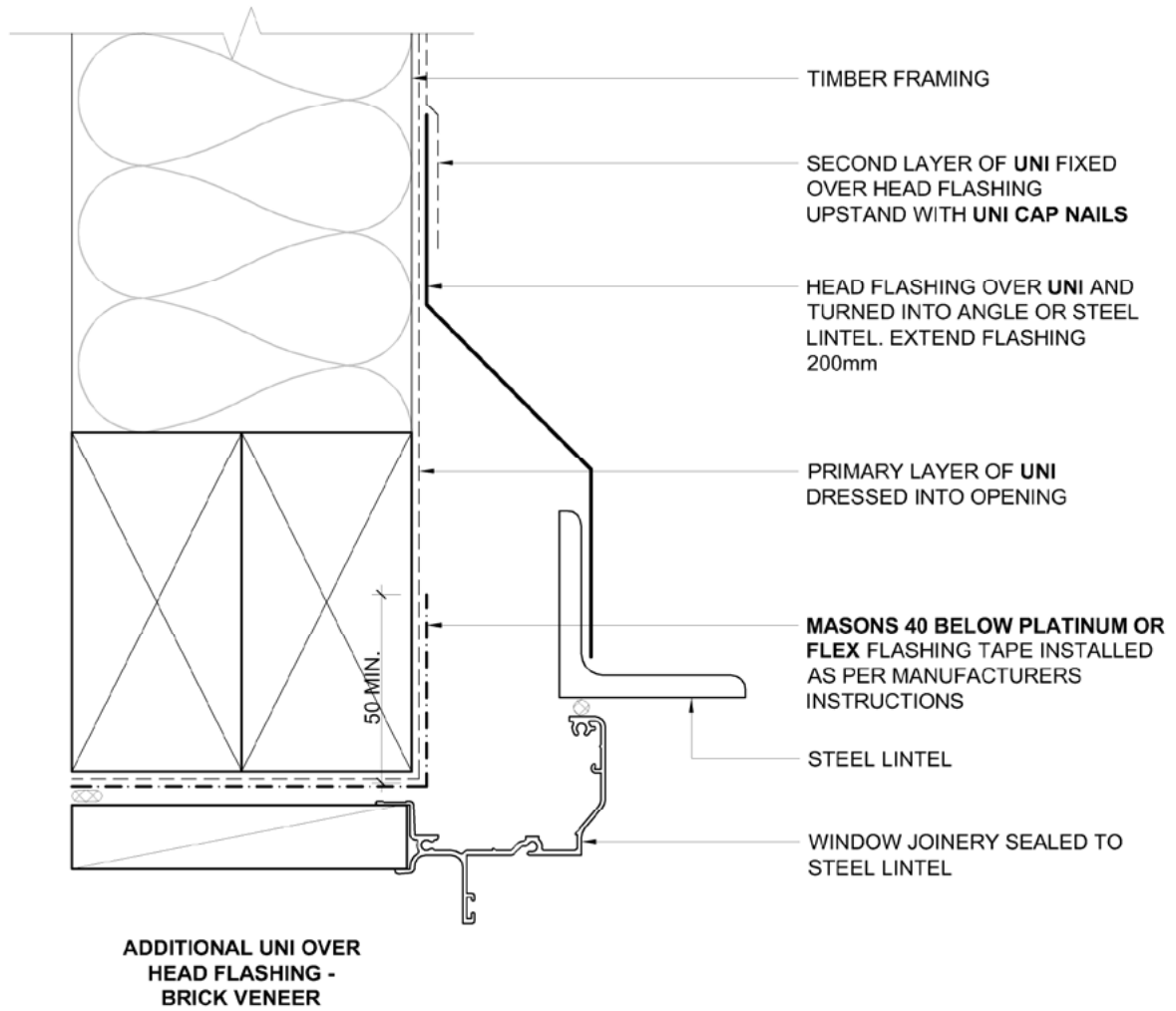

 <p>MASONS Designed Smart, Built Tough.</p>	<p>Brick Lintel Veneer Window Head UNI FAB, UNI Plus & UNI Pro</p>	Scale	Date
		<p>1:2</p>	
		Drawing Ref No.	
		UNI.06	

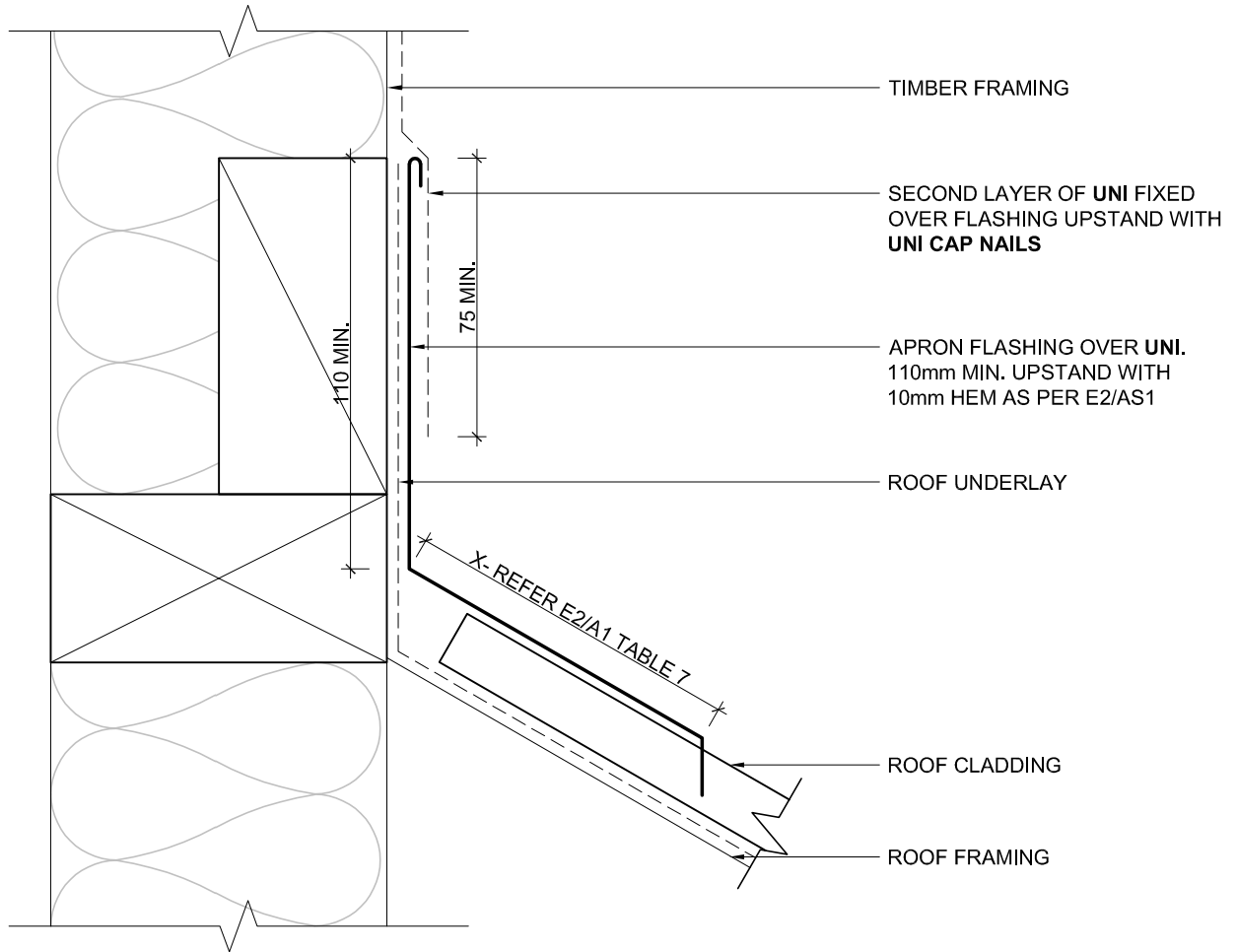

Apron Flashing Installation
UNI FAB, UNI Plus & UNI Pro

Scale
1:2

Date

Drawing Ref No.

UNI.07

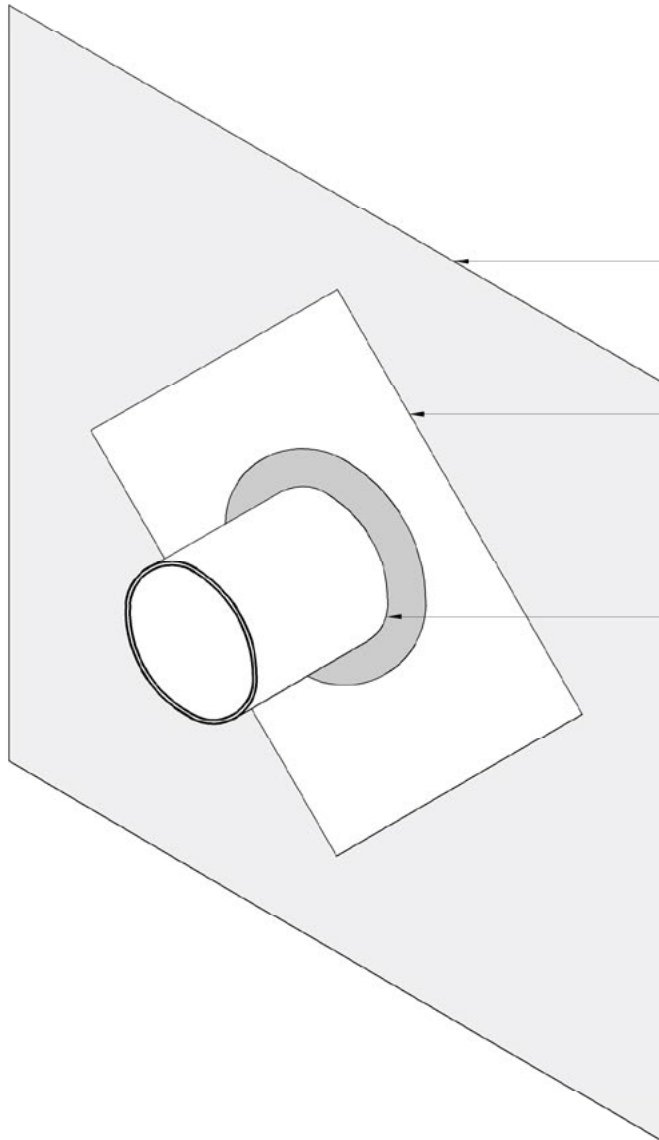

NOTE: MEASURE PIPE OR CONDUIT TO CHOOSE THE CORRECT SIZE MASONS PENETRATION SEAL

UNI FAB

MASONS 1-75mm PENETRATION SEAL OR 80-170mm MASONS PENETRATION SEAL, ORIENTATED AT 45°. PRESS FIRMLY ONTO UNI FAB WITH TAPE SCRAPER

CUT EDPM TO SNUG FIT ON PIPE OR CONDUIT

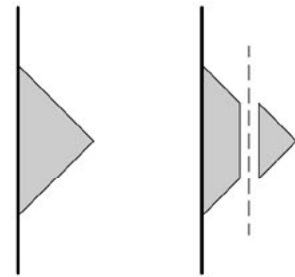

EDPM NOZZLE CUT TO SUIT PIPE



Penetration Seals
UNI FAB, UNI Plus & UNI Pro

Scale
1:2

Date

Drawing Ref No.
UNI.08

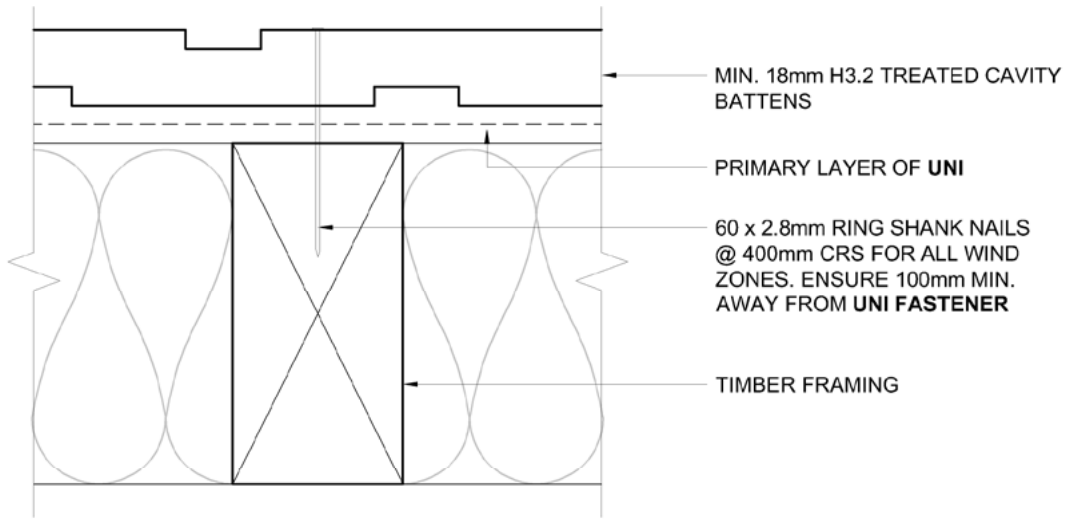

HORIZONTAL CAVITY BATTEN

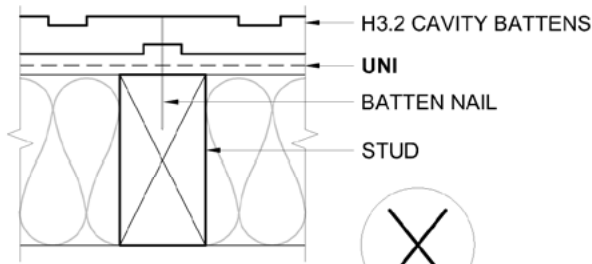

INCORRECT FIXING FOR VENTILATED BATTENS

NOTE:

- BATTEN FIXINGS REFER TO 'UNI WIND ZONE FIXING CHART'
- USE APPROPRIATE FIXING FOR CORROSION ZONE
- DO NOT FIX AT BATTEN NOTCHES
- MASONS WRAP STRAP IS RECOMMENDED BEFORE INSTALLING BATTENS TO PREVENT BUILDING WRAP FROM BULGING

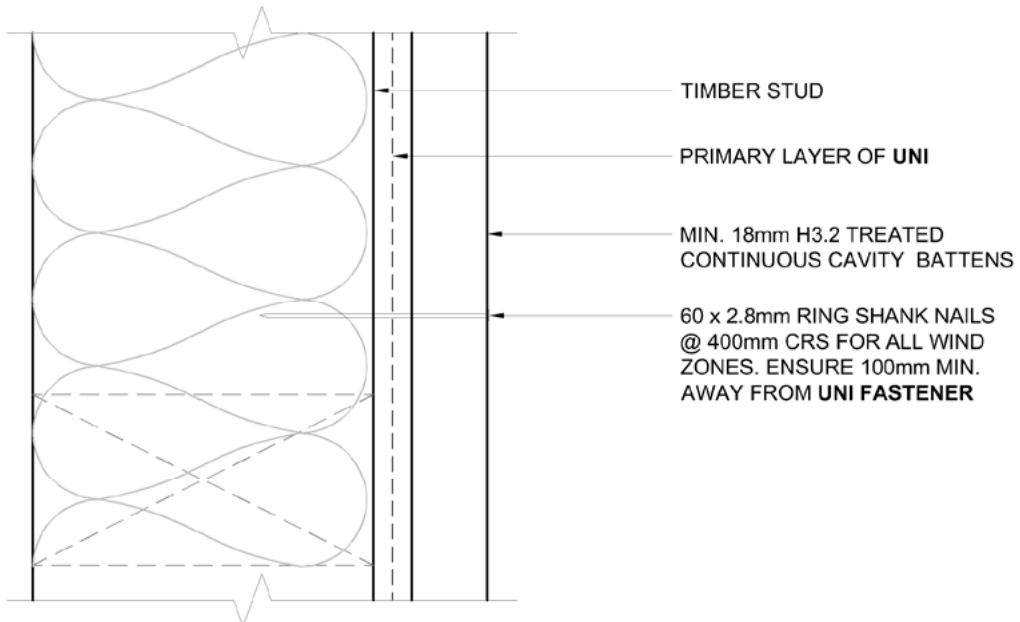

VERTICAL CAVITY BATTEN

 <p>MASONS Designed Smart, Built Tough.</p>	<p>CAVITY BATTEN FIXING UNI FAB, UNI Plus & UNI Pro</p>	<p>Scale 1:2</p>	<p>Date</p>
	<p>Drawing Ref No. UNI.09</p>		