

F150 Saddle Bracket - 100mm

Part No.

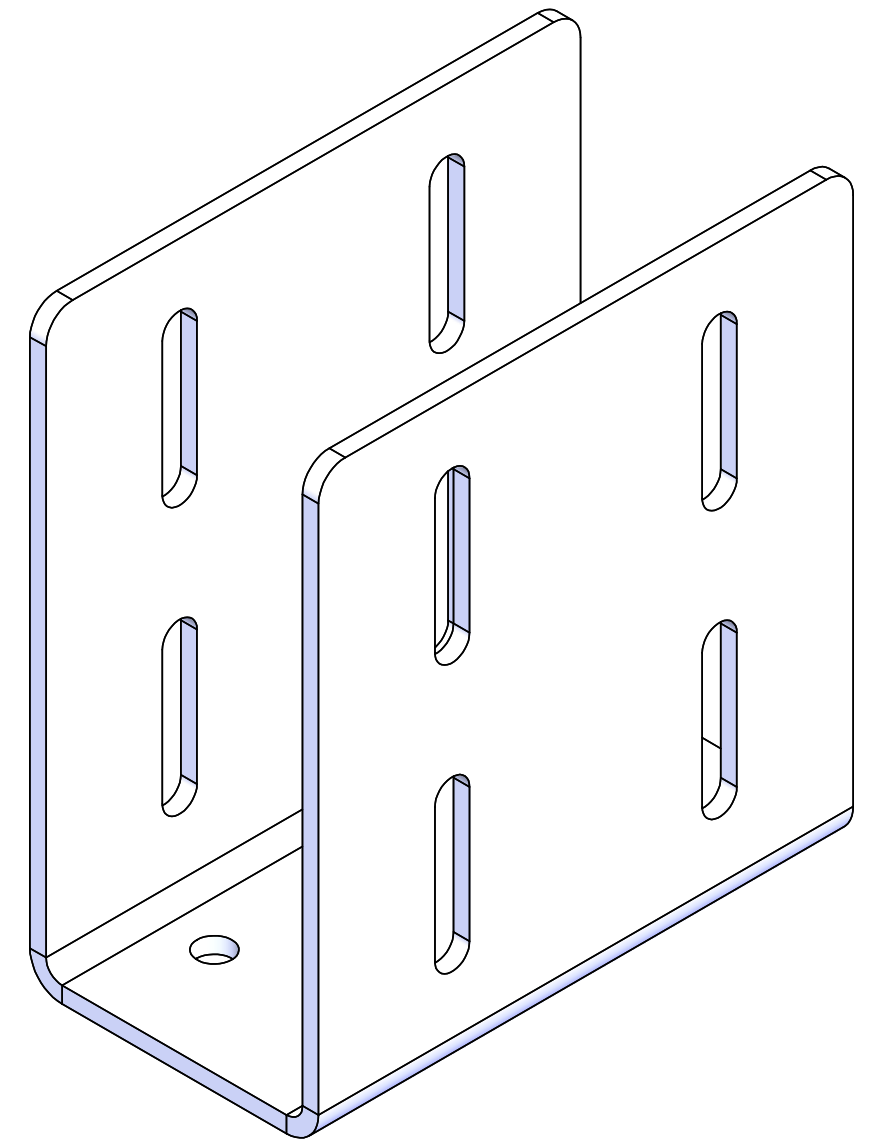
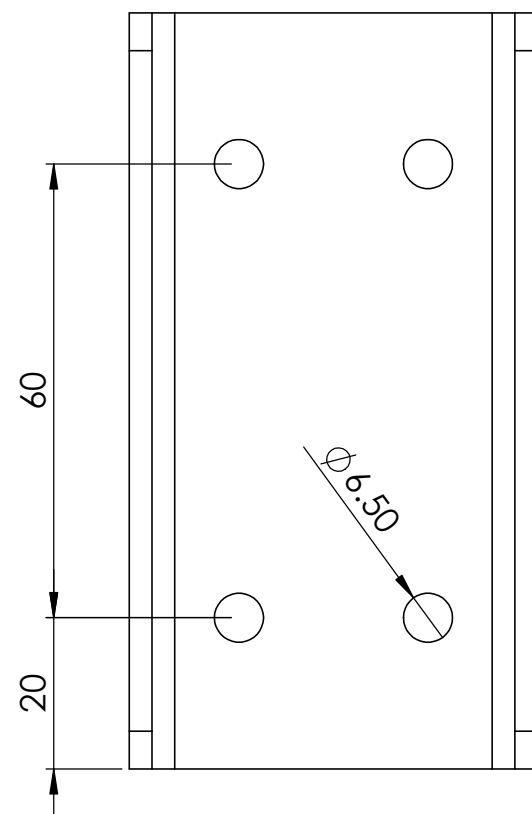
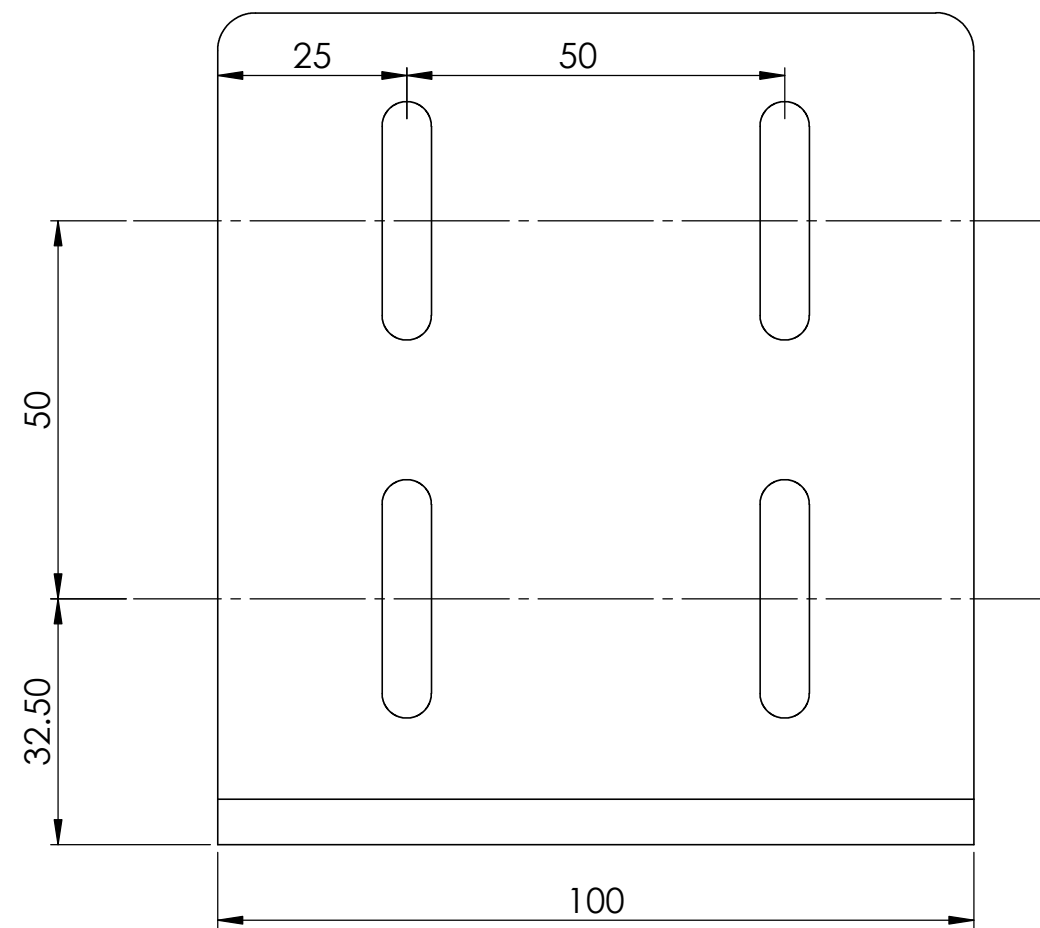
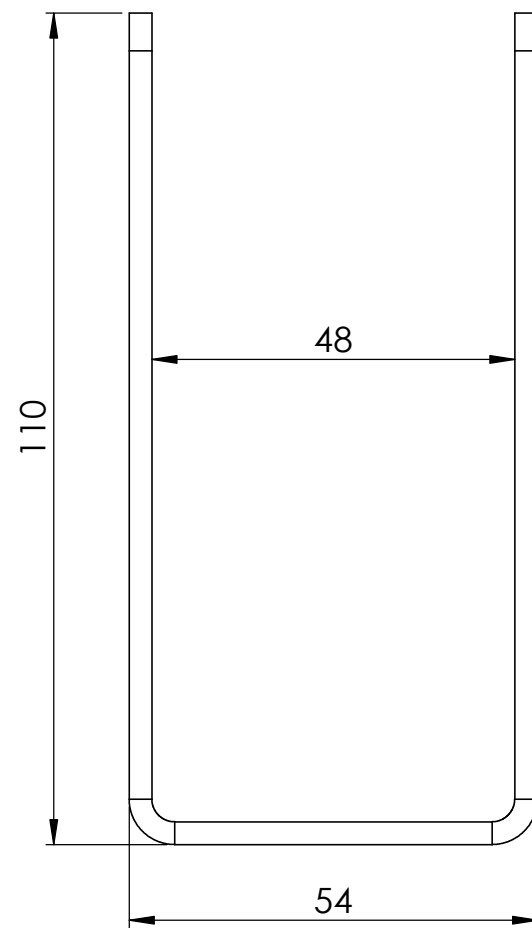

UGS
PO Box 84 262,
Westgate, Auckland
0657 New Zealand
Phone: +64 9 838 6429
www.ugs.co.nz

Description and Notes:
F150 Saddle Bracket - 100mm

Material:
3mm Aluminium

Finish:
POWDER COAT

Vendor:

Vendor Ref:

Weight (Kg):

Area (m²):

Design by: Peter Herrick

Drawn by: G.Termeh

Units: Metric (mm & Kg)

Scale: N/A

Date: 3/4/2022

Sheet: 3 of 3

Drawing No.

Rev:
A