

RESIDENTIAL SLIMLINE CORRUGATE WALL CLADDING JAMB FLASHING FOR VERTICAL CLADDING. (RECESSED WINDOW/DOOR)

Detail Number: RI-RSLW012B

Date drawn: 07/07/2017

Scale: 1 : 5@ A4

BUILDING WRAP DRESSED INTO
OPENING WITH 50mm RETURN TO
INSIDE OF FRAME WITH WINDOW
FLASHING TAPE INSTALLED OVER
WRAP TO CORNERS

ROOFING INDUSTRIES BACK
TRAY* FLASHING RUN FROM TOP
OF HEAD FLASHING TO GROUND
OR EXIT POINT

ROOFING INDUSTRIES
'SLIMLINE MINI CORRUGATE'

SCREW FIXING

CONTINUOUS COMPRESSIBLE
FOAM SEAL

ROOFING INDUSTRIES JAMB
FLASHING

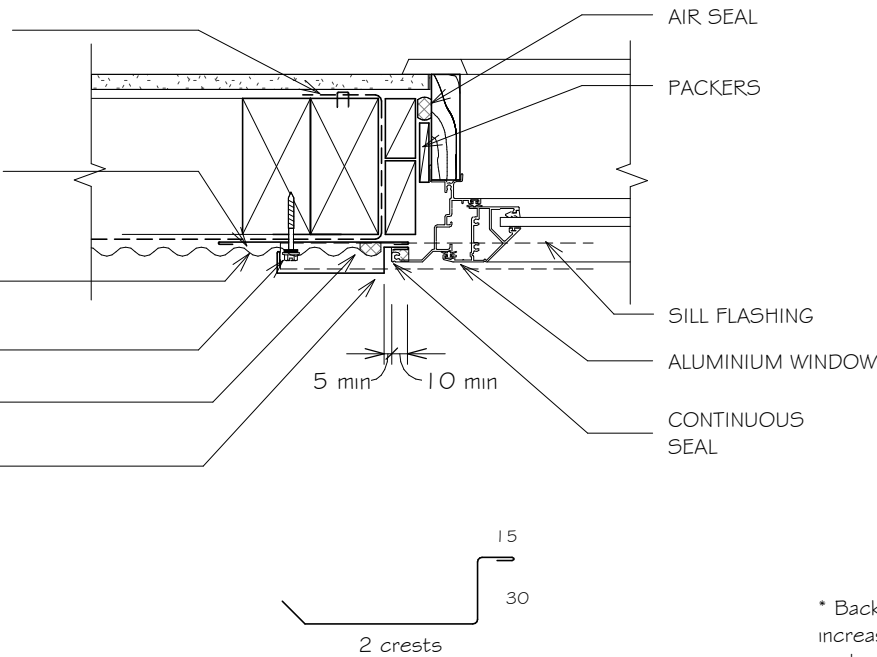

Alternate flashing option

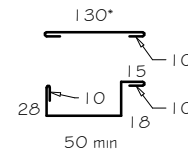

* Back tray size may require to
increase to ensure coverage at
ends of head flashing.

(Dimensions are indicative only)
Turn down end of head flashing

GENERAL NOTES:

1. REFER TO E2/AS1 FOR GENERAL WINDOW OPENING FOR WRAPPING OF FRAMED OPENING PRIOR TO WINDOW INSTALLATION.
2. A MIN. OF 8mm EFFECTIVE COVER AT SILLS SHALL BE PERMITTED WHERE NECESSARY TO ALLOW FOR TOLERANCES.
3. WINDOW PROFILE TO BE SELECTED TO ACHIEVE COVER SHOWN IN DETAILS.
4. ARCHITRAVE'S ARE SHOWN FOR CONSISTENCY ONLY, DETAIL MAY BE USED WITH REBATED LINER.
5. WHERE SUPPORT BRACKETS ARE REQUIRED BY THE WINDOW MANUFACTURER TO CARRY THE FRAME AND GLAZING LOADS THEY MUST BE SUPPLIED AS AN INTEGRAL PART OF THE WINDOW MANUFACTURER'S RECOMMENDATIONS.
6. LIASE WITH WINDOW MANUFACTURER PRIOR TO INSTALLATION.

REFERENCE FLASHINGS: NZ METAL
ROOF AND WALL CLADDING CODE
OF PRACTICE NZMRM SEPTEMBER
2008. SEE CODE OF PRACTICE
6.4.2A..
DIMENSIONS ARE INDICATIVE ONLY

NOTES:

- These details are generally in compliance with E2/AS1 and/or the NZ Metal Roof & Wall Cladding Code of Practice and in some cases specific details by 'Roofing Industries'.
- The building designer is ultimately responsible to ensure that details used meet the requirements of the NZ Building Code for the specific project.
- Details of the supporting structure including cavity battens are indicative only and are the responsibility of the building designer. For steel framed buildings thermal break cavity battens may be required.
- Underlay selection and building wrap types are the responsibility of the designer. When rigid wall underlay is required it is the designers responsibility to ensure the correct type is used and follow the manufacturers recommendation for installation.
- These details are for Roofing Industries profile/s as nominated and may not be applicable to other profiles.
- This drawing is the copyright of 'Roofing Industries' and can only be copied or reproduced with their permission.
- Further information can be obtained from the NZ Metal Roof & Wall Cladding Code of Practice: www.metalroofing.org.nz or E2/AS1.

SLIMLINE IS OUTSIDE THE SCOPE OF E2/AS1 BUT
MAYBE APPLICABLE FOR NON RESIDENTIAL
BUILDINGS OR AS AN ALTERNATIVE SOLUTION

Copyright detail © 2017

