

RESIDENTIAL RIBLINE® WALL CLADDING

METER BOX BASE FLASHING FOR VERTICAL CLADDING ON CAVITY

Detail Number: RI-RRW017A-1

Date drawn: 07/07/2017

Scale: 1 : 5@ A4

BUILDING WRAP DRESSED INTO
OPENING WITH 50mm RETURN TO
INSIDE OF FRAME WITH WINDOW
FLASHING TAPE FLUSH WITH INSIDE
OF FRAME

WATERPROOF AIRSEAL TO
PERIMETER OF TRIM CAVITY

SCREW FIXING TO
TROUGH

BUILDING WRAP

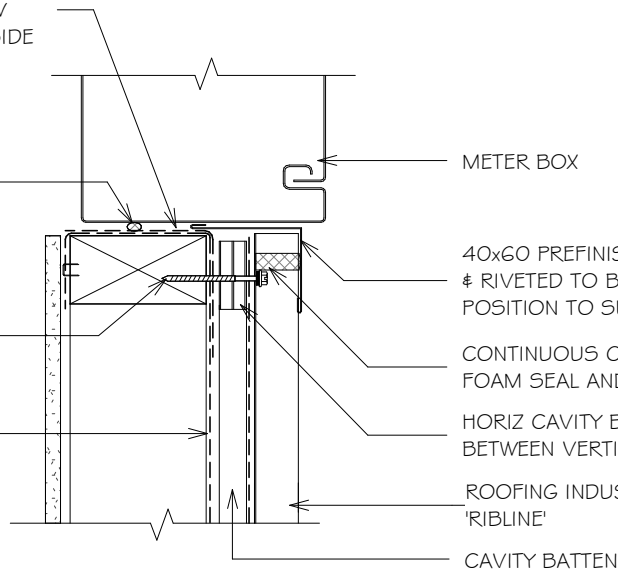

40x60 PREFINISHED STEEL ANGLE SEALED
& RIVETED TO BOTTOM OF METER BOX,
POSITION TO SUIT CLADDING.

CONTINUOUS COMPRESSIBLE
FOAM SEAL AND/OR STOP END

HORIZ CAVITY BATTEN
BETWEEN VERTICAL BATTENS

ROOFING INDUSTRIES
'RIBLINE'

CAVITY BATTEN

NOTES:

1. REFER TO E2/AS1 FOR GENERAL METERBOX AND SIMILAR PENETRATIONS / OPENINGS.
2. CAVITY BATTENS CONTAINING CORROSIVE MATERIAL MUST BE SEPERATED FROM METAL CLADDING BY DPC, BUILDING WRAP, PVC OR PAINTING
3. CASTELLATED BATTEN, DRAINAGE PLASTIC BATTEN OR APPROVED DRAINED BATTEN CAN BE USED WITH THIS SYSTEM

NOTES:

- These details are generally in compliance with E2/AS1 and/or the NZ Metal Roof & Wall Cladding Code of Practice and in some cases specific details by 'Roofing Industries'.
- The building designer is ultimately responsible to ensure that details used meet the requirements of the NZ Building Code for the specific project.
- Details of the supporting structure including cavity battens are indicative only and are the responsibility of the building designer. For steel framed buildings thermal break cavity battens may be required.
- Underlay selection and building wrap types are the responsibility of the designer. When rigid wall underlay is required it is the designers responsibility to ensure the correct type is used and follow the manufacturers recommendation for installation.
- These details are for Roofing Industries profile/s as nominated and may not be applicable to other profiles.
- This drawing is the copyright of 'Roofing Industries' and can only be copied or reproduced with their permission.
- Further information can be obtained from the NZ Metal Roof & Wall Cladding Code of Practice: www.metalroofing.org.nz OR NZBC clause E2/AS1.

Copyright detail © 2017

