

# RESIDENTIAL RIBLINE® ROOFING GUTTER APRON

Detail Number: RI-RRR004A

Date drawn: 07/07/2017

Scale: 1 : 5@ A4

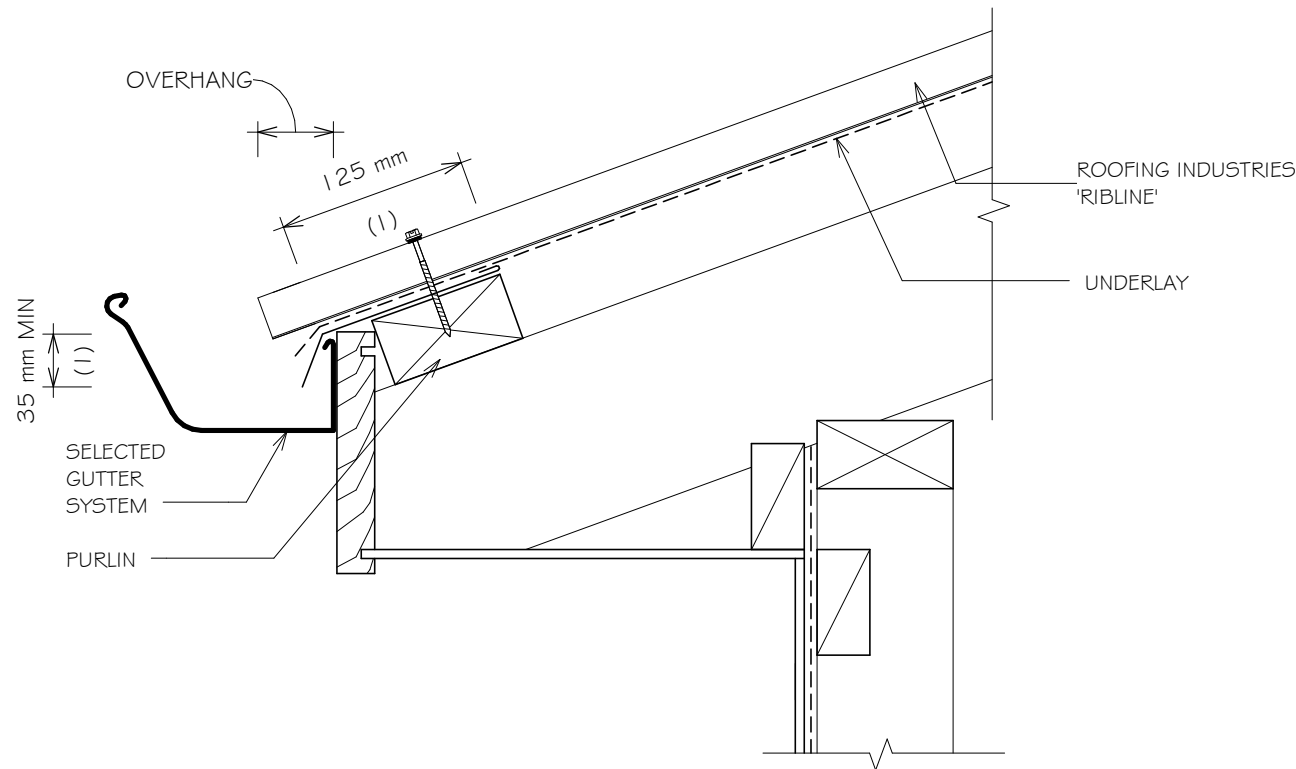

## NOTES:

1. REQUIRED TO ALL ROOFS UNDER 10° WHERE ALL OF THE FOLLOWING CONDITIONS No. 2-4 ARE MET.
2. ROOFS UNDER 10° PITCH.
3. WHERE EAVES OVERHANG IS LESS THAN OR EQUAL TO 100mm.
4. WHERE WIND ZONES ARE VERY HIGH OR EXTRA HIGH.
5. ALSO RECOMMENDED IN VERY CORROSIVE ENVIRONMENTS AND WHEN SPOUTING IS LOW.
6. DESIGNER MAY ALSO CHOOSE TO INCLUDE OPTIONALLY.
7. ALL ROOF CLADDING WITH A PITCH OF LESS THAN 8 DEGREES MUST BE PROVIDED WITH TURN DOWN TO ENSURE WATER IS DIRECTED INTO GUTTER.
8. ROOF OVERHANG:
 

< 10 DEGREES	= 70mm
10 - 35 DEGREES	= 50mm
35 - 40 DEGREES	= 40mm

REFER TO MRM CODE OF PRACTICE.

## NOTES:

- These details are generally in compliance with E2/AS1 and/or the NZ Metal Roof & Wall Cladding Code of Practice and in some cases specific details by 'Roofing Industries'.
- The building designer is ultimately responsible to ensure that details used meet the requirements of the NZ Building Code for the specific project.
- Details of the supporting structure including cavity battens are indicative only and are the responsibility of the building designer. For steel framed buildings thermal break cavity battens may be required.
- Underlay selection and building wrap types are the responsibility of the designer, Netting or other support is generally required at roof pitches less than 8 degrees combined with a self supporting paper. At roof pitches of 8° and above where non self supporting paper is used or purlin spacing is in excess of self supporting criteria, netting or other support should be used. Alternative support to netting should be used in severe coastal environments including when aluminium is used.
- These details are for Roofing Industries profile/s as nominated and may not be applicable to other profiles.
- This drawing is the copyright of 'Roofing Industries' and can only be copied or reproduced with their permission.
- These details to be read with Roofing Industries profile technical summary regarding wind loads and fixings.
- Further information can be obtained from the NZ Metal Roof & Wall Cladding Code of Practice: [www.metalroofing.org.nz](http://www.metalroofing.org.nz) OR NZBC clause E2/AS1.

Copyright detail © 2017

