

ROOF TRUSS INSTALLATION

General

The roof trusses you are about to install have been manufactured to precise engineering standards. To ensure that the trusses perform as designed, it is essential that they be handled, erected and braced correctly. The following recommendations apply to roof trusses on standard domestic buildings with roof truss details given by the MiTek 20/20® truss design program. Details for commercial, industrial and non-standard domestic buildings are to be provided by the engineer responsible for overall building design.

Design

1. Trusses are designed for normal residential roof, ceiling, snow and wind loads to suit specific jobs and conditions. Additional loading such as solar units, hot water tanks and air conditioning requires special consideration. Advice should be sought from the truss fabricator prior to commencing construction.
2. Wall frames and beams supporting trusses must be designed for the correct roof loads. Refer NZS 3604 Timber Framed Buildings or the MiTek® range of beams and lintels.
3. Wind load is an important loading condition in the design and performance of roof trusses. Ensure that you have correctly advised the truss fabricator with regard to wind load requirements and that adequate provision has been made to fix trusses to the supporting structure to withstand wind uplift forces.
4. Trusses are usually designed to be supported on the outer wall with internal walls being non-load bearing. Internal walls may be used to control deflections and reduce the camber required. Where it is necessary to use internal walls for load bearing, these will be clearly shown on the layout.
5. Before ordering trusses, ensure that your particular requirements have been provided for and that all relevant information has been supplied to the truss manufacturer. If non-standard trusses are being used, ensure that erection and bracing details are known before erection commences.
6. For environments where the atmosphere may be conducive to corrosion, such as some types of industrial and agricultural buildings, or buildings near the ocean and subject to salt spray consideration should be given to the use of stainless steel connector plates.



Important Note

1. It is the builder's responsibility to ensure that all relevant information required for the design is provided to the fabricator at time of ordering trusses, including spans, pitches, profiles, quantities and loading. Final confirmation of dimensions and details between the fabricator and builder is recommended prior to manufacture.
2. It is the responsibility of the principal to ensure that all provisions of the Health and Safety Act are complied with during the installation of MiTek® timber trusses.
3. Trusses are designed for specific loading, geometry and support conditions. Under no circumstances should the truss timber be cut, removed or trusses modified in any way without prior approval from the truss fabricator.
4. Make sure all bracing is permanently fixed and all bolts and brackets are tightened prior to the laying of roof.

Transport

Trusses must be fully supported when being transported in either a horizontal or vertical plane. Care must be taken when tying down not to put strain on chords or webs.

Timber or metal right angle protectors are a satisfactory method of avoiding damage. Unloading and handling as described on the next page.



INSTALLATION

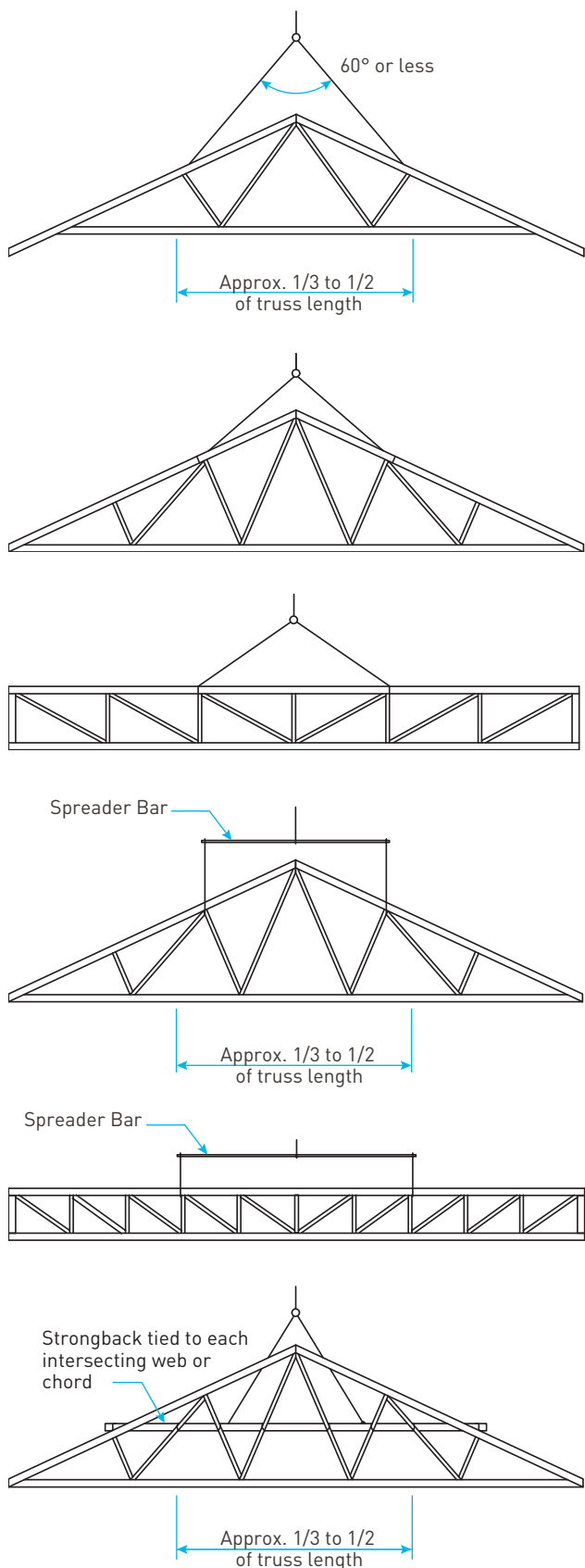

Job Storage and Lifting

Trusses should be inspected on arrival at site. Any damaged trusses should be reported immediately and not site repaired without approval of the truss fabricator.

Where it is anticipated that trusses will be stored on site for an extended period of time before use, adequate provision should be made to protect the trusses against the effects of weather. Protective covering should allow free air circulation around trusses.

Trusses when stored on the job site should be on timber billets clear of the ground and in flat position to avoid distortion.

When lifting, care must be taken to avoid damaging joints and timber. Spreader bars with attachment to the panel points are recommended where span exceeds 9000mm. Never lift by the apex joint only. The trusses may also be placed on the top plates by pulling them up skids, spread at 3000mm, taking the same precaution as described above. Ensure that the trusses are not distorted or allowed to sag between supports.

The recommended method of lifting trusses will depend on a number of factors, including truss length and shape.

In general, sling the truss from top chord panel points as shown in (Fig 1). Slings should be located at equal distance from truss centreline and be approximately 1/3 to 1/2 the truss length apart. Chains and hooks should not be used for lifting as these can damage the chords and plates. Polyester web slings are recommended.

The angle between the sling legs should be 60° or less and where truss spans are greater than 9000mm it is recommended that a spreader bar or strongback be used. Some typical examples are shown in (Fig 1).

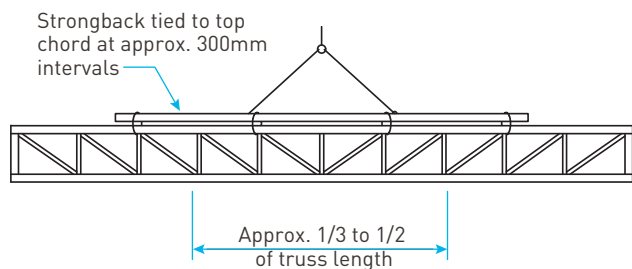
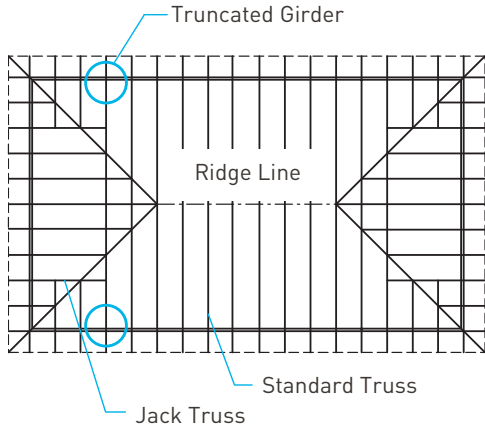

FIGURE 1.

INSTALLATION

Hip End



Semi Gable

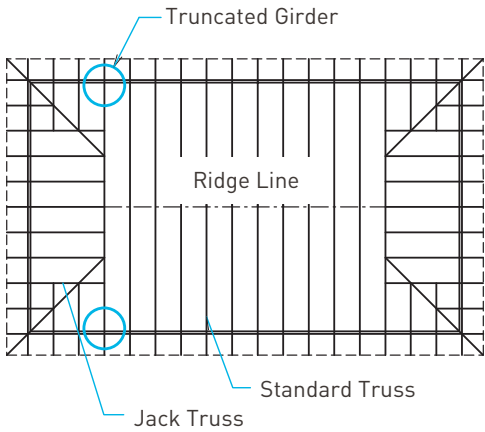

Gable

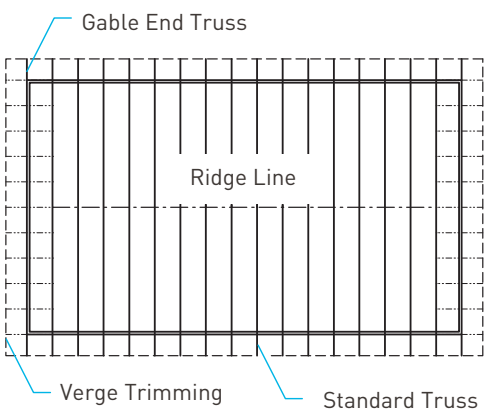

T Shaped

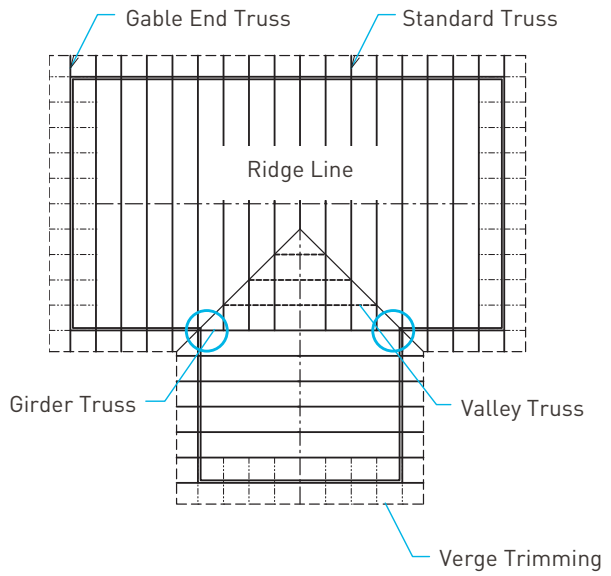

L Shape

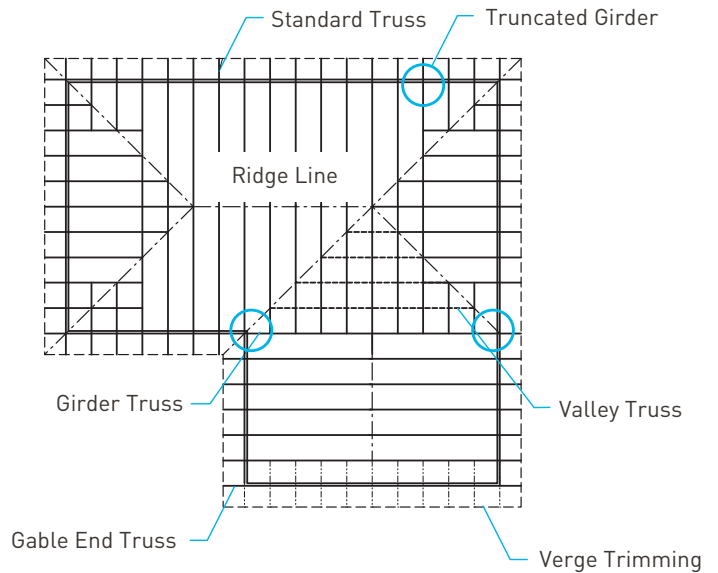

Load bearing points circled on these layouts may be critical.
Refer to the Wall Frame Construction Notes.

Note:

Gable End Truss to be located over end wall unless otherwise advised by supplier.

FIGURE 2.

INSTALLATION

Wall Frame Construction

The load bearing frames should be checked for:

1. Lintel sizes suitable for truss loading. Consult NZS 3604, the GANGLAM Beam Manual, the MiTek® FLITCH BEAM Manual or your truss fabricator.
2. If trusses are not located directly over the studs the top plate size must be in accordance with NZS 3604 or be reinforced in accordance with NZS 3604.
3. Girder trusses may require the strengthening of studs at the points of support. Check the loading with your truss fabricator. Points circled on the layout notes are critical.
4. The supporting structure construction must be adequate to resist wind uplift forces and must be fully braced, plumb and nailed home before the erection of trusses is commenced.

Erection and Fixing

It is convenient to mark the truss position on the wall plates before lifting the trusses. Use the layout drawing as your guide and note that the truss design spacing must not be exceeded.

Gable Roofs – start with a gable truss at each end, fixing it to the top plate at the position marked. These trusses must be temporarily braced back to the ground or frame at the panel points.

Hip or Semi Gable – start with the semi gable girder truss or the truncated girder, placing it on the top plate at the position marked and temporarily bracing it back to the frame. Locate hip and jack trusses and adjust girder truss position before fixing.

Line – Using a stringline along the apex (Fig 3), place each intermediate truss and fix it to the top plate at the position marked, spacing it with gauging rods and ties (Fig 6).

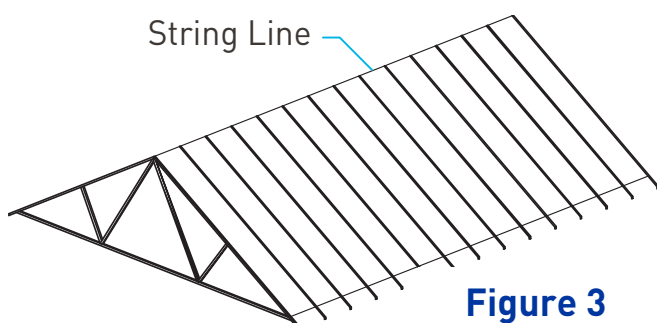

Figure 3

All trusses should be fixed to top plates and girder trusses in accordance with NZS 3604 or the specific roof truss design.

Camber

Trusses are usually manufactured with a camber built in. The camber is designed to give a flat ceiling and even roofline under long term loading. The camber is progressively taken up as the load from the roof covering and ceiling is applied. Under no circumstances should trusses be supported along the span (unless designed for) by blocking or propping.

If a truss has been designed to be supported internally a "SUPPORT HERE" label is affixed at the appropriate point.

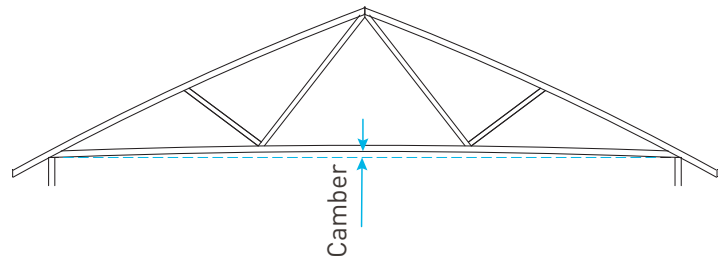

Figure 4

Erection Tolerances

Tolerance is critical for both a good roofline and effective bracing. A string line, plumb line or level should be used.

1. Trusses should be erected with overall bow or bow in any chord not to exceed the lesser of $L/200$ or 50mm (L is the chord length).
2. Trusses should be erected with the apex not more than the lesser of the span/200mm or 50mm from a vertical plane through the supports.
3. No section of the truss should be out of plumb by the truss height/50 or max. 50mm.

Generally if a bow or tilt is evident to the eye, the truss has been erected outside the tolerances. See (Fig 5).

INSTALLATION

Erection Bracing

The trusses must be braced during erection. If this is not done, then two problems can occur.

1. Collapse during erection.
2. Erection tolerance will be exceeded, causing overloading, buckling and possible permanent damage.

The exact details of erection bracing will, for practical purposes, differ from job to job. The following recommendations are for guidance only as the details employed are the responsibility of the erector.

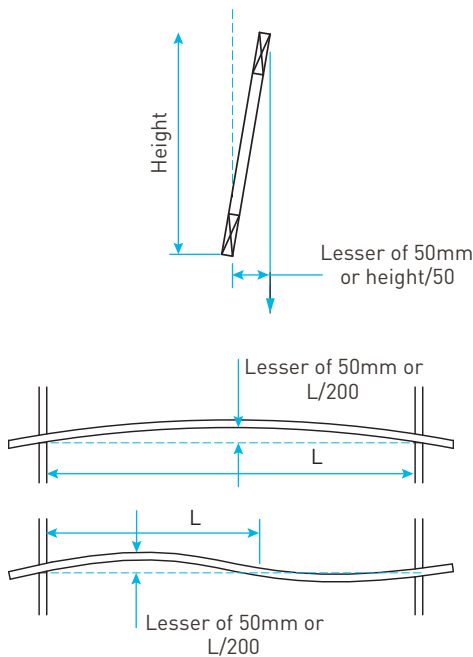

The first truss should be erected straight and plumb to erection tolerances given previously and temporarily braced to a rigid element, e.g. wall or ground as shown on (Fig 6).

Each successive truss should be spaced using a gauging rod, then fixed back to the first truss with temporary ties at each top chord panel point or at maximum spacing of 3000mm, and to bottom chord at 4000mm max. spacing.

Use 50 x 25 ties for trusses up to and including 900mm centres and 70 x 35 ties for trusses up to 1800mm centres. Fix ties to each truss with one 3.75 diameter nail. Splice by lapping over 2 adjacent trusses.

The purpose of installing temporary bracing is to hold trusses straight and plumb prior to fixing permanent bracing. Temporary bracing is particularly important when the roof cladding is shingles on ply without purlins. All permanent bracing, ties, hold downs, etc. must be fixed prior to laying of roof.

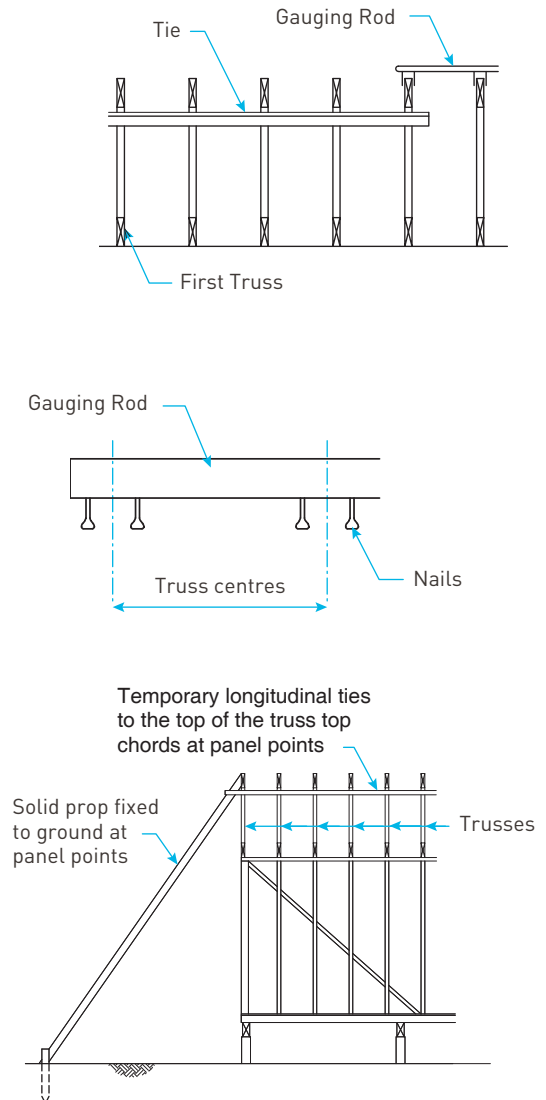

Important Note

These recommendations are a guide only for the erection of residential roof trusses up to 13000mm span and spaced at centres not exceeding 1200mm. For trusses beyond these conditions, consult your truss fabricator.